

Nitrous oxide generation in denitrifying phosphorus removal process: Main causes and control measures

Cong Li^{1,a}, Jian Zhang^{1,a}, Shuang Liang^{1*}, [Huu Hao Ngo²](#), [Wenshan Guo²](#), Yingying Zhang³, [Yina Zou¹](#)

(1) *Shandong Provincial Key Laboratory of Water Pollution Control and Resource Reuse, School of Environmental Science and Engineering, Shandong University, Jinan 250100, Shandong, China.*

(2) *School of Civil and Environmental Engineering, University of Technology Sydney, Broadway, NSW 2007, Australia.*

(3) *Melbourne School of Engineering, The University of Melbourne, Victoria, 3010, Australia.*

Abstract:

Despite the many benefits of denitrifying phosphorus removal process, the significant generation of nitrous oxide (N₂O), a potent greenhouse gas, remains a problem for this innovative and promising process. To better understand and more effectively control N₂O generation in denitrifying phosphorus removal process, batch experiments were carried out to investigate the main causes of N₂O generation, based on which the control measures were subsequently proposed. The results showed that N₂O generation accounted for 0.41% of the total nitrogen removal in denitrifying phosphorus removal process, whereas in contrast, almost no N₂O was generated in conventional denitrification process. It was further demonstrated that the weak competition of N₂O reductase for electrons and the higher nitrite accumulation were the two main causes for N₂O generation, evidenced by N₂O production and reduction

* Corresponding author. Tel.: +86 531 88361712; fax: +86 531 88364513. E-mail address: sliang@live.com (S. Liang).

^a The two authors contributed equally to this work

rate under different conditions. Accordingly, the reduction of N₂O generation was successfully achieved via two control measures: (i) the use of continuous nitrate addition reducing N₂O generation by around 91.4%, and (ii) the use of propionate as the carbon source reducing N₂O generation by around 69.8%.

Key words: Nitrous oxide; Denitrifying phosphorus removal; Causes; Control measures; Continuous nitrate addition; Propionate

1. Introduction

Nitrous oxide (N₂O) is a potent greenhouse gas. Although the proportion of N₂O in total greenhouse gas emissions is only 0.03%, N₂O has a more than 300-fold greater global warming potential (GWP) than carbon dioxide (CO₂), and it is increasing globally at a surprising rate of 0.31% per year (IPCC, 2007). Moreover, N₂O can contribute to the destruction of ozone layer through reacting with oxygen (O₂) to produce nitric oxide (NO) in the stratosphere (Ravishankara, 2009). It has long been known that biological wastewater treatment is an important source of N₂O emissions (Kampschreur et al., 2009; Li et al., 2010; Wunderlin et al., 2012). Therefore, it is urgent to identify the causes of N₂O emission and reduce this phenomenon from biological wastewater treatment process.

In the last two decades, many researchers have investigated N₂O generation from biological wastewater treatment process, and results showed that microbial nitrification and denitrification were the two sources of N₂O generation, and denitrification was observed to be the dominant process (Meyer et al., 2005; Tallec et

al., 2006; Jia et al., 2012). Denitrification is the reduction of nitrate (NO_3^- -N) to molecular nitrogen (N_2) by heterotrophic denitrifiers, with nitrite (NO_2^- -N), NO and N_2O as intermediates (Hu et al., 2011a). However, the final product was found to be N_2O rather than N_2 under certain conditions, such as low COD/N ratio, low pH, high NO_2^- concentration and using poly- β -hydroxyalkanoates (PHA) as carbon source for denitrification (Schalk-Otte et al., 2001; Itokawa et al., 2001; Zhou et al., 2008a).

Recently, the application of denitrifying phosphorus removal process has attracted intensive attention due to its simultaneously nitrogen (N) and phosphorus (P) removal relying on the ability of denitrifying P accumulating organisms (DPAOs) (Kuba et al., 1996; Zhou et al., 2008b; Wang et al., 2009). DPAOs could take up organic carbon sources in anaerobic phase and store them in the form of PHA with P release. The stored PHA are oxidized in the subsequent anoxic phase, while DPAOs use NO_3^- -N/ NO_2^- -N as the terminal electron acceptor for P removal instead of O_2 (Oehmen et al., 2007). This process reduces sludge production and the demand for oxygen and carbon sources, which is particularly suitable for treating low COD/N wastewater (Kuba et al., 1996).

However, using PHA for denitrification and high NO_2^- -N concentration are the important performance characteristics during denitrifying P removal process, and these characteristics are usually key factors resulting in N_2O generation (Zeng et al., 2003; Zhou et al., 2012). More precisely, it has been reported in previous literature that N_2O generation from denitrifying P removal process was determined to be 2.3%-37.9% of the total N removal (Wang et al., 2011a, b). N_2O generation reduces

the practical application of this process. However, most studies of N₂O generation from denitrifying P removal process mainly focused on the influence factors such as nitrite, anaerobic reaction time and carbon source (Zhou et al., 2008a; Wang et al., 2011a, b), and the mechanism and control measures for N₂O generation have not yet been clearly described.

Therefore, the aim of this paper was to identify the causes of N₂O generation in denitrifying P removal process, and evaluate the control measures of N₂O generation. For this purpose, the N₂O generation characteristics between denitrifying P removal process and conventional denitrification process were examined and compared throughout the study. Then, the causes of high N₂O generation in denitrifying P removal process were investigated by batch experiments. Finally, in order to control N₂O generation, the effects of nitrate addition strategies and carbon sources on N₂O generation were investigated.

2. Materials and Methods

2.1. Sludge Sources

Denitrifying P removal sludge from a lab-scale anaerobic-anoxic/nitrifying sequencing batch reactor (A₂N-SBR) and conventional denitrification sludge from anoxic-aerobic sequencing batch reactor (AO-SBR) were used to carry out the experiments.

Fig.1 shows the schematic diagram of the A₂N-SBR. The A₂N-SBR consisted of an anaerobic–anoxic SBR (A₂-SBR) operated under alternating anaerobic, anoxic, and aerobic conditions, and a separate nitrification SBR (N-SBR) operated under aerobic

condition. Each reactor had a working volume of 5 L and was operated with a cycle time of 8 h. In each cycle, 4 L of synthetic wastewater was fed into the A₂-SBR leading to a volume exchange ratio of 80%. After a further 90 min anaerobic reaction and 40 min settling, 4 L of supernatant (rich in $\text{NH}_4^+\text{-N}$ and $\text{PO}_4^{3-}\text{-P}$) was flowed into the N-SBR where $\text{NH}_4^+\text{-N}$ was oxidized to $\text{NO}_3^-\text{-N}$ during 150 min aerobic reaction. The effluent of N-SBR containing $\text{NO}_3^-\text{-N}$ and $\text{PO}_4^{3-}\text{-P}$ was pumped into A₂-SBR in 2 min before the beginning of anoxic reaction. After 180 min anoxic reaction, 30 min aerobic reaction and 40 min setting, 4 L treated wastewater was discharged from the system.

AO-SBR had a working volume of 5 L and was worked with a cycle time of 6 h consisting of 10 min feeding, 90 min anoxic, 180 min aerobic, 50 min setting and decanting, and 20 min idle periods. In each cycle, 2.5 L of synthetic wastewater was fed into the reactor during the feeding period, resulting a hydraulic retention time of 12 h.

2.2. Synthetic wastewater

The synthetic wastewater contained CH_3COONa (77 mg/L), $\text{CH}_3\text{CH}_2\text{COONa}$ (120 mg/L), NH_4Cl (153 mg/L), NaHCO_3 (200 mg/L), KH_2PO_4 (11 mg/L), $\text{K}_2\text{HPO}_4\cdot 3\text{H}_2\text{O}$ (18 mg/L), $\text{MgSO}_4\cdot 7\text{H}_2\text{O}$ (10 mg/L), $\text{FeSO}_4\cdot 7\text{H}_2\text{O}$ (10 mg/L), $\text{CaCl}_2\cdot 2\text{H}_2\text{O}$ (10 mg/L) and trace elements solution (1 mL/L). The trace elements solution was: H_3BO_3 (150 mg/L), $\text{CuSO}_4\cdot 5\text{H}_2\text{O}$ (30 mg/L), KI (180 mg/L), $\text{MnCl}_2\cdot 4\text{H}_2\text{O}$ (120 mg/L), $\text{Na}_2\text{MoO}_4\cdot 2\text{H}_2\text{O}$ (60 mg/L), $\text{ZnSO}_4\cdot 7\text{H}_2\text{O}$ (120 mg/L), $\text{CoCl}_2\cdot 6\text{H}_2\text{O}$ (150 mg/L) and ethylene diamine tetraacetic acid (EDTA, 10 g/L) (Hu et

al., 2011b). The concentrations of COD, $\text{NH}_4^+\text{-N}$ and TP were approximately 200, 40 and 5 mg/L, respectively.

2.3. Batch Experiments

In order to investigate the causes and control measures of N_2O generation in denitrifying P removal process, five series batch experiments were conducted. For batch experiments, two types of reactors were used, one with 0.1 L overhead space had a working volume of 1.4 L, and the other reactor without overhead space had a working volume of 0.25 L. The magnetic stirrers were used to keep the suspension of the sludge, and the temperature was controlled at 24 ± 1 °C.

2.3.1. N_2O generation characteristics in denitrifying P removal process and conventional denitrification process

Batch experiments 1 was carried out to investigate the differences of N_2O generation in denitrifying P removal process and conventional denitrification process. The sludge for this experiment was withdrawn from $\text{A}_2\text{-SBR}$ and AO-SBR at the end of aerobic phase, respectively, and then washed three times with distilled water. After being removed the supernatant, the sludge was transferred into two reactors (SBR-1 and SBR-2). Next, 1.12 L of synthetic wastewater was fed into each reactor. Then, distilled water was added to make the final volume of each reactor to be 1.4 L, resulting in an initial COD, $\text{NH}_4^+\text{-N}$, $\text{PO}_4^{3-}\text{-P}$ concentrations of 160, 10 and 5 mg/L, respectively. SBR-1 was operated with 90 min anaerobic reaction and 180 min anoxic reaction, and KNO_3 was pulse added at the end of anaerobic phase, giving an initial concentration of $\text{NO}_3^-\text{-N}$ of approximately 25 mg/L. SBR-2 was operated with 180

min anoxic reaction, and KNO_3 was pulse added at the beginning of anoxic phase, and the initial concentration of NO_3^- -N was also 25 mg/L.

2.3.2 Identifying causes of N_2O generation in denitrifying P removal process

Batch experiments 2 and 3 were carried out to analyze the causes of N_2O generation in denitrifying P removal process, by investigating the N_2O production and reduction rates under different conditions. Batch experiments 2, 4 L mixed liquor was withdraw from A_2 -SBR at the end of anaerobic phase, and divided evenly into four batch reactors (R1, R2, R3 and R4). R1 and R2 were then amended with KNO_3 solution to give an initial NO_3^- -N concentration of 25 mg/L, while R3 and R4 received NaNO_2 solution to provide an initial NO_2^- -N concentration of 20 mg/L. At the same time, a certain amount of acetate was added into R2 and R4 to give an initial COD concentration of 80 mg/L. The anoxic reaction lasted for 180 min, and N_2O microsensor (Unisense, Denmark) was used to measure the dissolved N_2O concentration.

The sludge mixture (1L) for batch experiments 3 was taken from A_2 -SBR at the end of anaerobic phase, and divided equally into four 250 mL reactors (r1, r2, r3 and r4). A certain amount of N_2O saturated solution was added to the reactors, resulting in an initial dissolved N_2O -N concentration of about 4 mg/L. [N₂O saturated solution was prepared according to the method of Pan et al. \(2012\).](#) Meanwhile 80 mg/L COD were prepared in r2 and r4 by adding acetate, and 25 mg/L NO_3^- -N were prepared in r3 and r4. The anoxic reaction lasted for 30 min, and dissolved N_2O concentration was detected by N_2O microsensor.

2.3.3 Controlling N_2O generation in denitrifying P removal process

In order to decrease N_2O generation in denitrifying P removal system, batch experiments 4 and 5 were used to study the effects of nitrate addition strategies and carbon sources on N_2O generation, respectively. Batch experiments 4, sludge mixture (2.8 L) were withdrawn from A_2 -SBR at the end of anaerobic phase, and directly transferred to two batch reactors (Run 1 and Run 2). For Run 1, 35 mL KNO_3 solution (1 g/L) was pulse added. However, 35 mL KNO_3 solution was continuously fed into Run 2 in 2 hours by a peristaltic pump (BQ50-1J, Longer). The anoxic reaction lasted for 180 min.

Batch experiments 5, 4.2 L sludge mixture were taken from A_2 -SBR at the end of aerobic phase. The washed sludge was divided equally into three reactors (run 1, run 2 and run 3). Like batch experiment 1, synthetic wastewater and distilled water were supplied to each reactor. However, the carbon sources in three reactors were different, and run 1, run 2 and run 3 were fed with acetate, acetate/propionate and propionate, respectively. The three reactors were operated as SBR-1.

2.4 Analytical methods

The analyses of COD, NH_4^+ -N, NO_3^- -N, NO_2^- -N, PO_4^{3-} -P, MLSS and MLVSS were conducted in accordance with Standard Methods (Chinese SEPA, 2002). PHA including Poly-b-hydroxybutyrate (PHB), poly-hydroxyvalerate (PHV) and poly-3-hydroxy-2-methylvalerate (PH2MV) were measured according to the method described by Oehmen et al. (2005). NO_3^- -N and NO_2^- -N reduction rates were determined according to the method described by Wang et al. (2011b). The off-gas

N_2O collection and calculation were based on the methods of Yang et al. (2009). N_2O concentration in gas phase and liquid phase were measured with Gas chromatography (GC) (SP-3410, China) and N_2O microsensor (Unisense, Denmark), respectively.

3. Results and discussion

3.1. N_2O generation characteristics

After over four months of operation period, stable N and P removal were achieved in A_2 -SBR and AO-SBR. Then batch experiments 1 were carried out to investigate the differences of N_2O generation between denitrifying P removal process and conventional denitrification process.

Figures 2 and 3 show the variations of COD, N, P, and PHA during N removal via denitrifying P removal (in SBR-1) and conventional denitrification (in SBR-2) in a typical cycle. During the anaerobic phase of SBR-1, COD was rapidly decreased to the lowest level within 30 min, and this was accompanied by the synthesis of PHA, release of $\text{PO}_4^{3-}\text{-P}$. In the subsequent anoxic phase, simultaneous denitrification and $\text{PO}_4^{3-}\text{-P}$ uptake was occurred, and PHA was consumed (Fig. 2). SBR-1 showed a typical DPAOs phenotype. Unlike the SBR-1, there was only anoxic phase in SBR-2. During the anoxic phase, COD consumption, $\text{NO}_3^- \text{-N}$ reduction and $\text{PO}_4^{3-}\text{-P}$ release were simultaneously occurred, and only a small amount of PHA was formed (Fig. 3). SBR-2 showed a conventional denitrifying bacteria phenotype.

In SBR-1, it was found that N_2O was mainly produced in anoxic phase, and nearly no N_2O was detected in anaerobic phase; once KNO_3 solution was added to the reactor, dissolved $\text{N}_2\text{O}\text{-N}$ concentration increased rapidly to 0.87 mg/L in the first 15

min and decreased drastically to around zero (Fig. 2). Like SBR-1, a transient accumulation of N₂O was also observed at the beginning of anoxic period in SBR-2 (Fig. 3). However, the highest dissolved N₂O concentration in SBR-2 was only 0.08 mg/L, which was much lower than that in SBR-1. Furthermore, the N₂O emission was also measured and the total N₂O generation amount (in gas and liquid phases) was quantified in Table 1. It can be seen that although N₂O generation amount in SBR-1 (0.41±0.034% of the TN removal) was much higher than that (0.013±0.0056%) in SBR-2, it was much lower than those (2.34%~21.6%) reported in previous denitrifying P removal systems (Wang et al., 2011ab). This may be attributed to the use of a mixing carbon source containing both of propionate and acetate rather than the use of acetate alone in previous studies. Compared with acetate, the use of propionate as carbon source significantly decreased N₂O generation in wastewater treatment process (Zhu and Chen, 2011).

3.2. Identifying the causes of N₂O generation in denitrifying P removal process

SBR-1 used PHA as a carbon source for denitrification, while SBR-2 used acetate and propionate as carbon source for denitrification, and the NO₂⁻-N accumulation concentration in SBR-1 was much higher than that in SBR-2. Therefore, we speculated that using PHA for denitrification and higher NO₂⁻-N accumulation caused the difference of N₂O generation in the two reactors.

3.2.1. Using PHA for denitrification caused N₂O generation

The cause was first tested by adding acetate in anoxic batch experiments 2 using denitrifying P removal sludge (Fig. 4). The obtained results showed that when acetate

was not added to the reactor, DPAOs used PHA which was synthesized in anaerobic phase as carbon source for denitrification, and the maximum N₂O-N accumulation reached to 0.85 mg/L. However, when acetate was added, DPAOs could use acetate as a carbon source for denitrification, and the maximum N₂O-N accumulation was only 0.21 mg/L. These results indicated that using PHA for denitrification would increase the N₂O generation. Compared with acetate, the rate of PHA degradation was slow, which cannot provide enough electrons for denitrification, and this would lead to competition for electrons between denitrifying enzymes (Kampschreur et al., 2009). N₂O reductase (Nos) could not have a competitive advantage at capturing electrons due to the reduction of N₂O is the last step of denitrification, and the N₂O reduction would be inhibited (Kampschreur et al., 2009; Wang et al., 2011b).

In order to prove the above hypothesis, batch experiments 3 were conducted and the results were shown in Fig 5. Fig 5 showed that acetate addition significantly increased N₂O reduction rate, because acetate degradation rate is 6-20 times faster than PHA, and Nos could obtain enough electrons for N₂O reduction (Third et al., 2003). When nitrate was added to the batch reactors, N₂O reduction was inhibited, because nitrate reductase (Nar) had a competitive advantage for electrons over Nos, and the electrons provided by PHA oxidation were first used for nitrate reduction (Kampschreur et al., 2009). Whereas when acetate and nitrate were both supplied, the N₂O reduction was not inhibited, because the electrons provided by acetate were sufficient for both nitrate and N₂O reduction. These results indicated that when using PHA for denitrification, the limited electrons provided by PHA could not satisfy the

requirement of denitrifying enzymes, and Nos had a weak competition for electrons when compared to Nar.

3.2.2. High NO_2^- -N concentration caused N_2O generation

From Figs. 2 and 3, it was found that NO_2^- -N accumulated in SBR-1 up to 8.51 mg/L, which was much higher than that in SBR-2 (4.91 mg/L). The possible reason is that SBR-1 used the internal carbon source (PHA) as carbon source for denitrification, while SBR-2 used acetic acid and propionic acid for denitrification. As the lower PHA degradation rate caused denitrifying enzymes competing for electrons, the nitrate reduction rate was much higher than nitrite reduction rate (Kampschreur et al., 2009; Wang et al., 2011b). The batch experiment 2 was then conducted to confirm NO_2^- -N accumulation caused N_2O generation.

From Fig. 4, it was also found that nitrite addition to the DPAOs sludge significantly stimulated the N_2O generation, and the maximum N_2O -N accumulation reached to 6.19 mg/L which was much higher than that in the nitrate addition reactor. This finding is consistent with the results reported by Lemaire et al. (2006), indicating that the N_2O production rate with nitrite addition was five times higher than that with nitrate addition. Likewise, Zhou et al. (2008a) demonstrated that the high level of NO_2^- -N caused the accumulation of N_2O . They later revealed that the activity of Nos was inhibited by high NO_2^- -N accumulation (Zhou et al., 2011).

However, it was observed an interesting phenomenon from batch tests 2 (Fig. 4). When nitrite and acetate was both added to the DPAOs sludge, the N_2O generation was much lower than that in the only nitrite addition reactor. This result also

explained why nearly no N_2O was generated in conventional denitrification process, although NO_2^- -N accumulation reached to 4.91 mg/L. The external carbon source could decrease the nitrite inhibition on Nos activity.

Therefore, the weak competition of Nos for electrons and higher NO_2^- -N accumulation were the two main reasons for N_2O generation in denitrifying phosphorus removal system.

3.3. Controlling N_2O generation during denitrifying phosphorus removal process

As N and P could be simultaneously removed using the same carbon source, denitrifying P removal offered a great potential to save the requirement for carbon sources and oxygen. However, lots of N_2O would be generated, which severely impedes the application of this process. Based on the above analysis, two measures could possibly reduce N_2O generation during denitrifying P removal: (a) using continuous nitrate addition to decrease the competition for electrons between denitrifying enzymes; (b) using propionate as carbon source to decrease nitrite accumulation.

3.3.1. The effects of nitrate addition strategies on N_2O generation

Nitrate was pulse added to the reactors, and the NO_3^- -N concentration was always at relatively high levels (25 mg/L) at the beginning of anoxic phase. The electrons which were provided by PHA oxidation could not be satisfied the requirement for reducing NO_3^- to N_2 , and the limited electrons were firstly used to reduce NO_3^- -N to NO_2^- -N and N_2O . If applying the continuous nitrate addition strategy, the NO_3^- -N concentration could be managed at the relatively low levels. So,

the requirement of electrons for complete conversion of NO_3^- -N to N_2 would be enough, and the N_2O accumulation would be decreased. N_2O and NO_2^- -N accumulation under pulse nitrate addition condition was compared with that under continuous addition condition by batch experiments 4. Fig. 6 showed that N_2O generation varied between the two different kinds of nitrate addition strategies. The continuous addition significantly decreased the N_2O generation and NO_2^- -N accumulation. Zhou et al. (2008b) also found that the N_2O generation was decreased in a novel 2-sludge 3-stage system by feeding the nitrite-containing stream continuously to the anoxic stage.

3.3.2. The effects of carbon sources on N_2O generation

NO_2^- -N accumulation was the main reason for N_2O generation in denitrifying P removal process. N_2O generation would be decreased if the NO_2^- -N accumulation was reduced. Propionate was good carbon source for DPAOs, and it could decrease the NO_2^- -N accumulation in denitrifying P removal process (Carvalho et al., 2007). Therefore, the N_2O generation would be reduced if using propionate as carbon source for DPAOs. The superiority of propionate for N_2O reduction was clearly evidenced by the results of batch tests 5 (Fig. 7, Table 1). It showed that compared with acetate and the mixture of acetate and propionate, using propionate as the sole carbon source significantly decreased NO_2^- -N accumulation and N_2O generation. NO_2^- -N is an intermediate of denitrification, and its accumulation is affected by the activities of Nar and nitrite reductase (Nir) (Wang et al., 2011a). The carbon sources can exert different effects on Nar and Nir activities, leading to a different ratio of nitrate reduction rate

(N1) to nitrite reduction rate (N2). The high ratio of N1/N2 could cause high NO_2^- -N accumulation (Wang et al., 2011a; Zhu and Chen, 2011). As can be seen in Table 2, the use of propionate as carbon source decreased the ratio of N1/N2, which was consistent with the lower NO_2^- -N accumulation.

However, these results disagreed with the conclusions of Wang et al. (2011a), who reported that N_2O generation was significantly increased when using acetate/propionate or propionate as carbon source in short-term experiments. The differences between the two studies were that DPAOs in this study was acclimatized by acetate/propionate, whereas DPAOs in their study was only acclimatized by acetate. The species of DPAOs in the two studies might be different. More research efforts are needed to further investigate the relationship between N_2O generation and microbial community in denitrifying P removal process acclimatized with different carbon sources.

Therefore, using continuous nitrate addition or propionate as a carbon source could decrease the N_2O generation in denitrifying P removal process. Furthermore, several measures have been reported to decrease N_2O generation in biological nitrogen and phosphorous removal process, such as reducing anaerobic time, using sludge alkaline fermentation liquid, and adding copper ion (Cu^{2+}) (Wang et al. 2011b; Zhu and Chen, 2011; Zhu et al. 2012). The applicability of these measures in denitrifying P removal process is therefore worth further research efforts.

4. Conclusion

Compared with the conventional denitrification process, the denitrifying P removal process significantly increased N₂O generation. Two main reasons were responsible for N₂O generation. One is using PHA for denitrification could lead to competition for electrons between denitrifying enzymes, and N₂O reductase could not have a competitive advantage at capturing electrons; the other is too much nitrite would be accumulated, and the activity of N₂O reductase would be inhibited. Therefore, N₂O generation could be decreased via two pathways: (a) using continuous nitrate addition to decrease the competition for electrons between denitrifying enzymes; (b) using propionate as a carbon source to decrease the nitrite accumulation.

Acknowledgements

This work was supported by Natural Science Foundation for Distinguished Young Scholars of Shandong province (No. JQ201216), National Natural Science Foundation of China (No. 21177075, 21007032, 50908133), Program for New Century Excellent Talents in University (No. NCET -10-0554).

References

- Carvalho G, Lemos PC, Oehmen A, Reis MAM (2007) Denitrifying phosphorus removal: Linking the process performance with the microbial community structure. *Water Res* 41:4383-4396.
- Hu Z, Zhang J, Xie HJ, Li SP, Wang JH, Zhang TT (2011a) Effect of anoxic/aerobic phase fraction on N₂O emission in a sequencing batch reactor under low temperature. *Bioresour Technol* 102:5486-5491.

- Hu Z, Zhang J, Xie HJ, Li SP, Zhang TT, Wang JH (2011b) Identifying sources of nitrous oxide emission in anoxic/aerobic sequencing batch reactors (A/O SBRs) acclimated in different aeration rates. *Enzyme Microb Technol* 49:237-245.
- IPCC (2007) Changes in atmospheric constituents and in radiative forcing. In: Solomon S et al.(ed), *Climate Change 2007: The Physical Science Basis. Contribution of working group I to the fourth assessment report of the Intergovernmental Panel on Climate Change*. Cambridge University Press, Cambridge, pp 114-143.
- Itokawa H, Hanaki K, Matsuo T (2001) Nitrous oxide production in high-loading biological nitrogen removal process under low COD/N ratio condition. *Water Res* 35:657-664.
- Jia WL, Zhang J, Xie HJ, Yan YJ, Wang JH, Zhao YX, Xu XL (2012) Effect of PHB and oxygen uptake rate on nitrous oxide emission during simultaneous nitrification denitrification process. *Bioresour Technol* 113:232-238.
- Kampschreur MJ, Temmink H, Kleerebezem R, Jetten MSM, van Loosdrecht MCM (2009) Nitrous oxide emission during wastewater treatment. *Water Res* 43:4093-4103.
- Kuba T, van Loosdrecht MCM, Heijnen JJ (1996) Phosphorus and nitrogen removal with minimal cod requirement by integration of denitrifying dephosphatation and nitrification in a two-sludge system. *Water Res* 30:1702-1710.
- Lemaire R, Meyer R, Taske A, Crocetti GR, Keller J, Yuan ZG (2006) Identifying causes for N₂O accumulation in a lab-scale sequencing batch reactor performing

- simultaneous nitrification, denitrification and phosphorus removal. *J Biotechnol* 122:62-72.
- Li HJ, Chen XR, Chen YG (2010) Effect of the addition of organic carbon sources on nitrous oxide emission in anaerobic-aerobic (low dissolved oxygen) sequencing batch reactors. *Front Environ Sci Engin China* 4:490-499.
- Meyer RL, Zeng RJ, Giugliano V, Blackall LL (2005) Challenges for simultaneous nitrification, denitrification, and phosphorus removal in microbial aggregates: mass transfer limitation and nitrous oxide production. *FEMS Microbiol Ecol* 52:329-338.
- Oehmen A, Keller-Lehmann B, Zeng RJ, Yuan ZG, Keller J (2005) Optimisation of poly-beta-hydroxyalkanoate analysis using gas chromatography for enhanced biological phosphorus removal systems. *J Chromatogr A* 1070:131-136.
- Oehmen A, Lemos PC, Carvalho G, Yuan ZG, Keller J, Blackall LL, Reis MAM (2007) Advances in enhanced biological phosphorus removal: from micro to macro scale. *Water Res* 41:2271-2300.
- Pan YT, Ye L, Ni BJ, Yuan ZG (2012) Effect of pH on N₂O reduction and accumulation during denitrification by methanol utilizing denitrifiers. *Water Res* 46:4832-4840.
- Ravishankara AR, Daniel JS, Portmann RW (2009) Nitrous oxide (N₂O): the dominant ozone-depleting substance emitted in the 21st century. *Science* 326:123-125.
- Schalk-Otte S, Seviour RJ, Kuenen JG, Jetten MSM (2000) Nitrous oxide (N₂O)

- production by *Alcaligenes faecalis* during feast and famine regimes. *Water Res* 34:2080-2088.
- Tallec G, Garnier J, Billen G, Gousailles M (2006) Nitrous oxide emissions from secondary activated sludge in nitrifying conditions of urban wastewater treatment plants: Effect of oxygenation level. *Water Res* 40:2972-2980.
- Third KA, Burnett N, Cord-Ruwisch R (2003) Simultaneous nitrification and denitrification using stored substrate (PHB) as the electron donor in an SBR. *Biotechnol Bioeng* 83:706-720.
- Wang YY, Peng YZ, Stephenson T (2009) Effect of influent nutrient ratios and hydraulic retention time (HRT) on simultaneous phosphorus and nitrogen removal in a two-sludge sequencing batch reactor process. *Bioresour Technol* 100:3506-3512.
- Wang YY, Geng JJ, Guo G, Wang C, Liu SH (2011a) N₂O production in anaerobic/anoxic denitrifying phosphorus removal process: The effects of carbon sources shock. *Chem Eng J* 172:999-1007.
- Wang YY, Geng JJ, Ren ZJ, He WT, Xing MY, Wu M, Chen SW (2011b) Effect of anaerobic reaction time on denitrifying phosphorus removal and N₂O production. *Bioresour Technol* 102:5674-5684.
- Wunderlin P, Mohn J, Joss A, Emmenegger L, Siegrist H (2012) Mechanisms of N₂O production in biological wastewater treatment under nitrifying and denitrifying conditions. *Water Res* 46:1027-1037.
- Yang Q, Liu XH, Peng CY, Wang SY, Sun HW, Peng YZ (2009) N₂O production

during nitrogen removal via nitrite from domestic wastewater: main sources and control method. *Environ Sci Technol* 43:9400-9406.

Zeng RJ, Saunders AM, Yuan ZG, Blackall LL, Keller J (2003) Identification and comparison of aerobic and denitrifying polyphosphate-accumulating organisms. *Biotechnol Bioeng* 83:140-148.

Zhou Y, Pijuan M, Zeng RJ, Yuan ZG (2008a) Free nitrous acid inhibition on nitrous oxide reduction by a denitrifying-enhanced biological phosphorus removal sludge. *Environ Sci Technol* 42:8260–8265.

Zhou Y, Pijuan M, Yuan ZG (2008b) Development of a 2-sludge, 3-stage system for nitrogen and phosphorous removal from nutrient-rich wastewater using granular sludge and biofilms. *Water Res* 42:3207-3217.

Zhou Y, Oehmen A, Lim M, Vadivelu V, Ng WJ (2011) The role of nitrite and free nitrous acid (FNA) in wastewater treatment plants. *Water Res* 45:4672-4682.

Zhou Y, Lim M, Harjono S, Ng WJ (2012) Nitrous oxide emission by denitrifying phosphorus removal culture using polyhydroxyalkanoates as carbon source. *J Environ Sci-China* 24:1616-1623.

Zhu XY, Chen YG (2011) Reduction of N₂O and NO generation in anaerobic–aerobic (low dissolved oxygen) biological wastewater treatment process by using sludge alkaline fermentation liquid. *Environ. Sci. Technol.* 45:2137-2143.

Zhu XY, Chen YG, Chen H, Li X, Peng YZ, Wang SY (2012) Minimizing nitrous oxide in biological nutrient removal from municipal wastewater by controlling copper ion concentrations. *Appl. Microbiol. Biotechnol.* DOI

10.1007/s00253-012-3988-1.

Table 1N₂O generation amount and denitrification efficiency in batch experiments^a

Reactor	N ₂ O generation amount (mg N/L)	Ratio of N ₂ O generation to denitrified nitrogen (%)	Denitrification efficiency (%)
SBR-1	0.083±0.0076	0.41±0.034	90.66±3.47
SBR-2	0.0027±0.00092	0.013±0.0056	100
pulse feed	0.089±0.0074	0.40±0.036	88.51±3.60
continuous feed	0.0071±0.0033	0.035±0.014	81.58±4.73
acetate	0.21±0.028	0.83±0.011	100
acetate + propionate	0.096±0.010	0.43±0.0054	90.01±3.17
propionate	0.025±0.0035	0.13±0.0076	76.93±6.40

^aThe data are the averages and their standard deviations in triplicate tests.

Table 2

Comparison of the reduction rates of NO_3^- -N and NO_2^- -N with different carbon sources^a

Carbon source	NO_3^- -N reduction rate (N1) ^b	NO_2^- -N reduction rate (N2) ^b	N1/N2
acetate	0.43±0.036	0.18±0.031	2.39
acetate + propionate	0.33±0.029	0.17±0.025	1.94
propionate	0.19±0.022	0.17±0.028	1.12

^a The data are the averages and their standard deviations in triplicate tests.

^b The unit of reduction rate is mg N/g VSS/min.

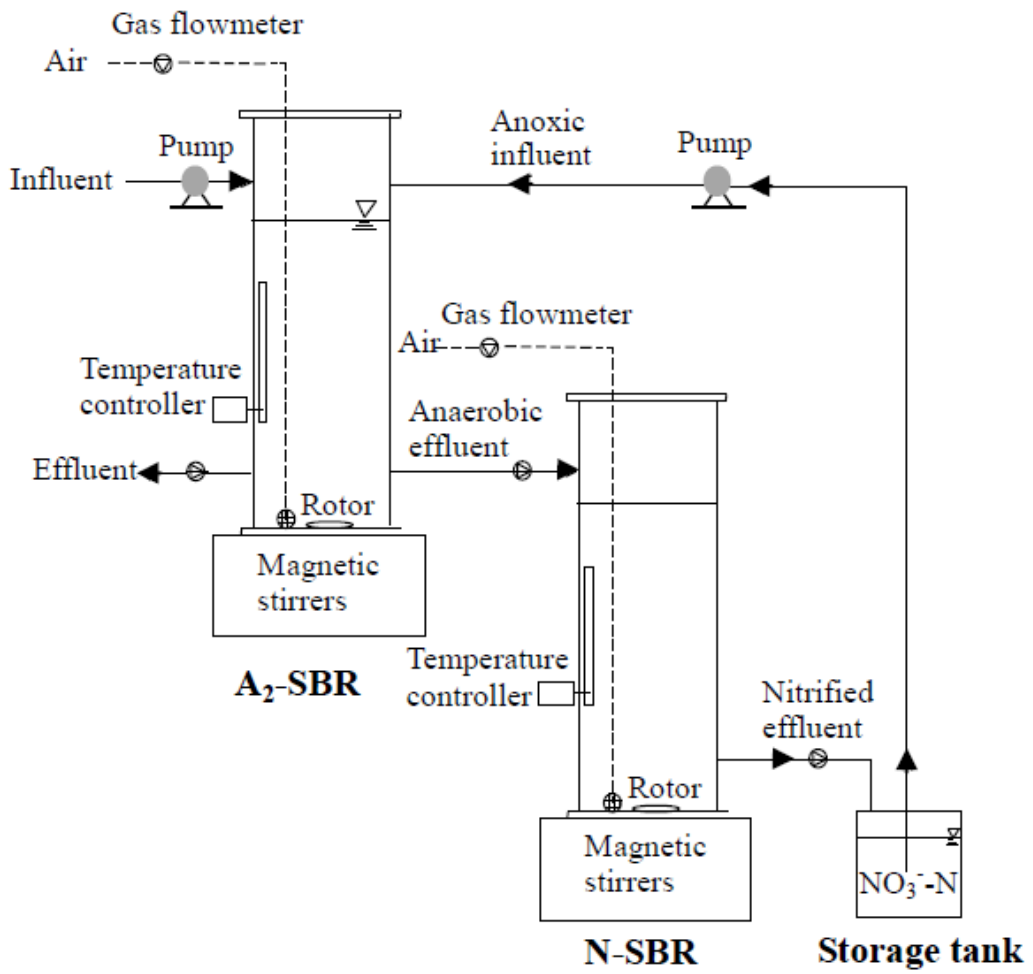

Fig. 1. The schematic diagram of the A₂N-SBR.

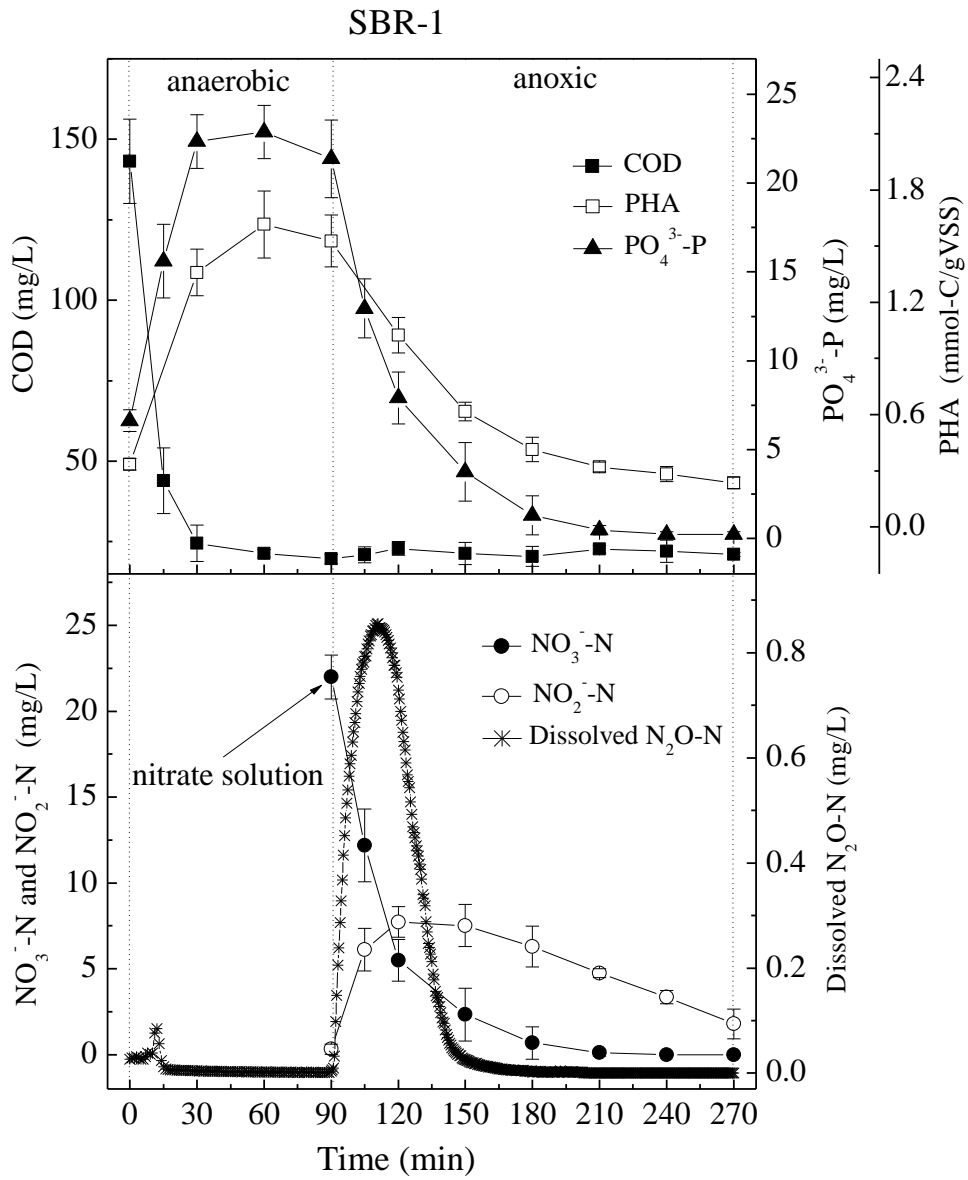

Fig. 2. Variations of COD, PHA, PO₄³⁻-P, NO₃⁻-N, NO₂⁻-N and dissolved N₂O concentrations during nitrogen removal via denitrifying phosphorus removal in SBR-1. Error bars represent standard deviations of triplicate tests.

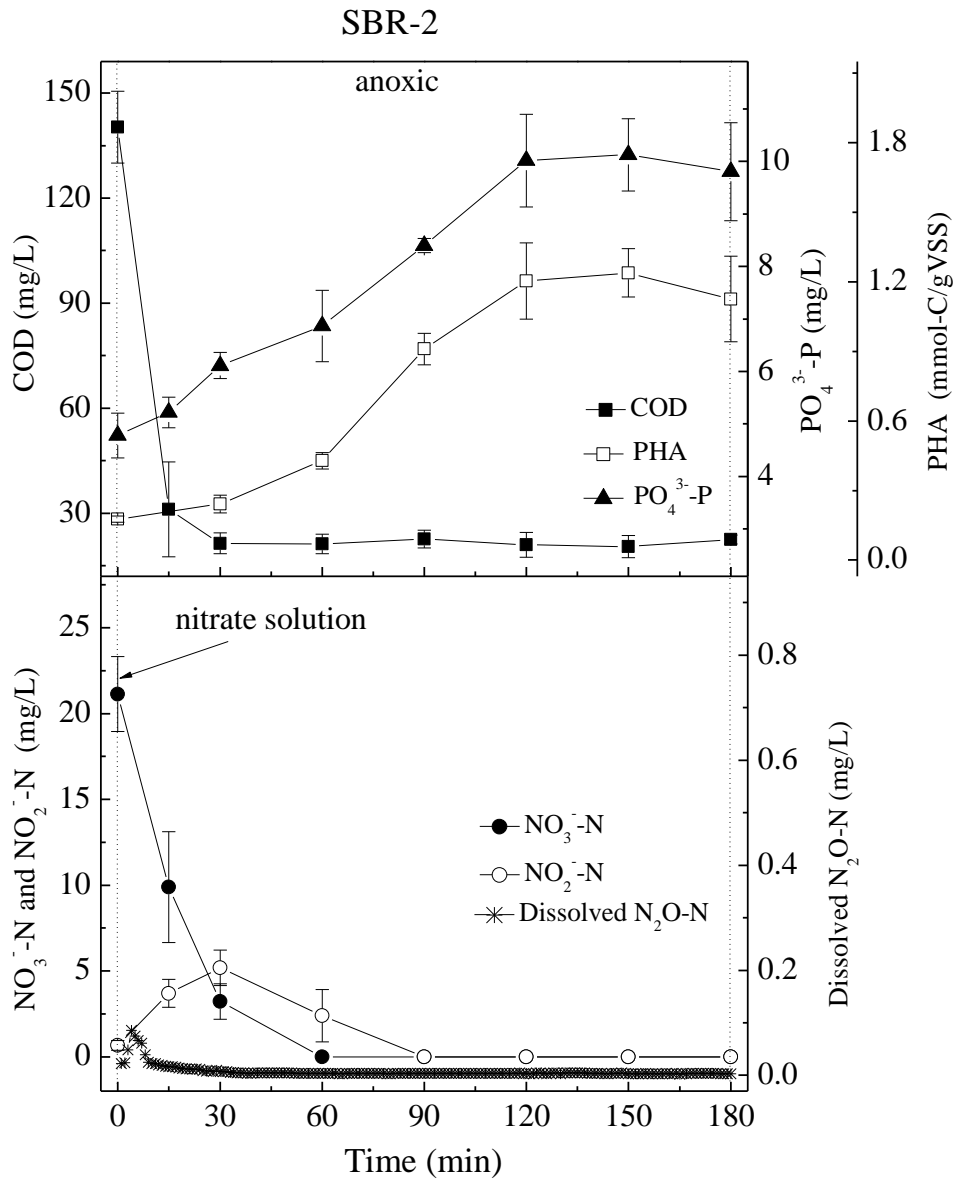

Fig. 3. Variations of COD, PHA, PO₄³⁻-P, NO₃⁻-N, NO₂⁻-N and dissolved N₂O concentrations during nitrogen removal via conventional denitrification in SBR-2. Error bars represent standard deviations of triplicate tests.

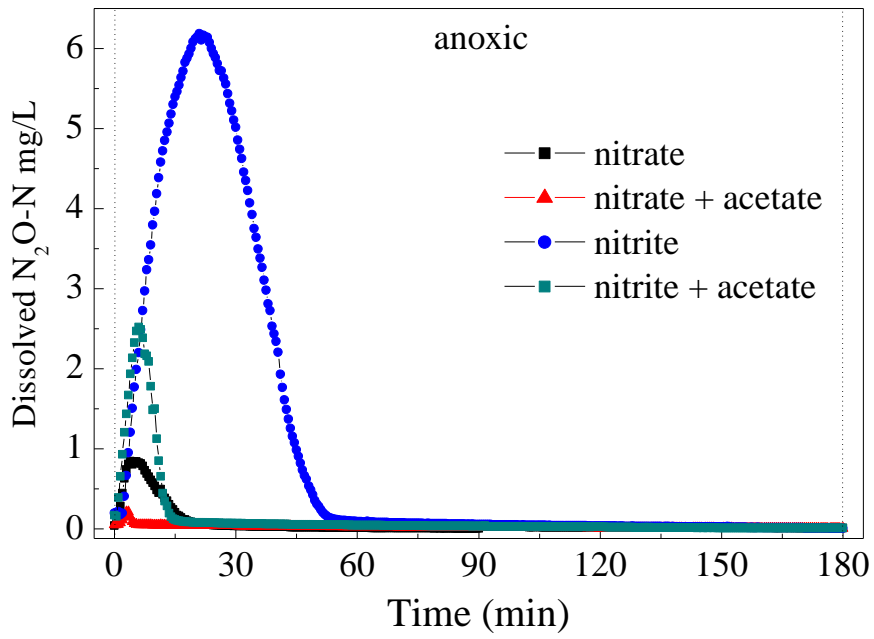

Fig. 4. N_2O production profiles during four batch experiments with the addition of nitrate, nitrate+acetate, nitrite, and nitrite+acetate using denitrifying phosphorus removal sludge.

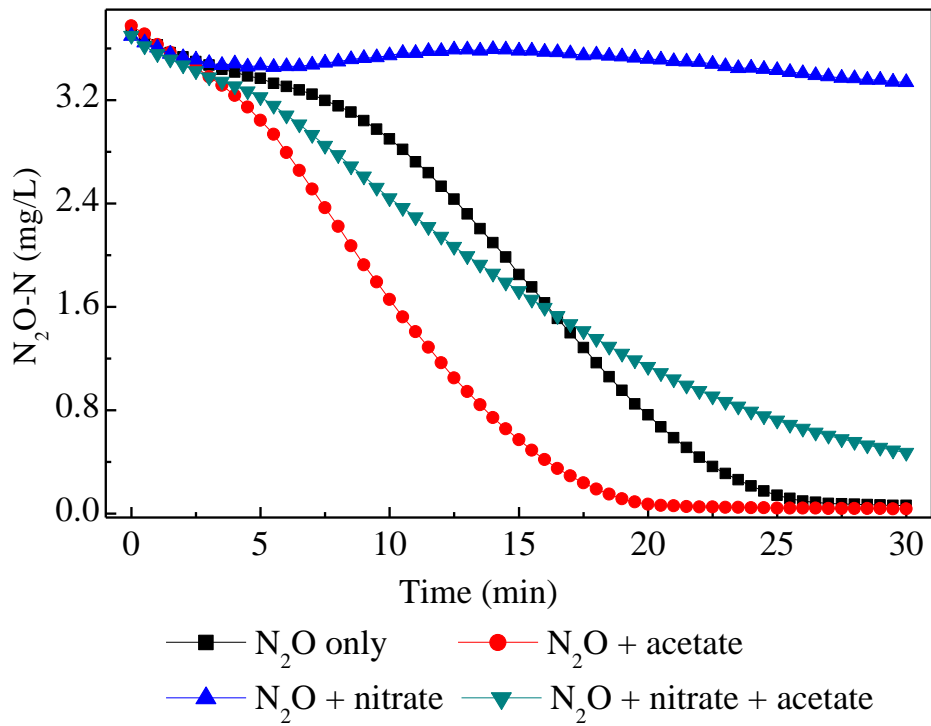

Fig. 5. N₂O reduction profiles during four batch experiments with the addition of acetate, nitrate, and nitrate+acetate using denitrifying phosphorus removal sludge.

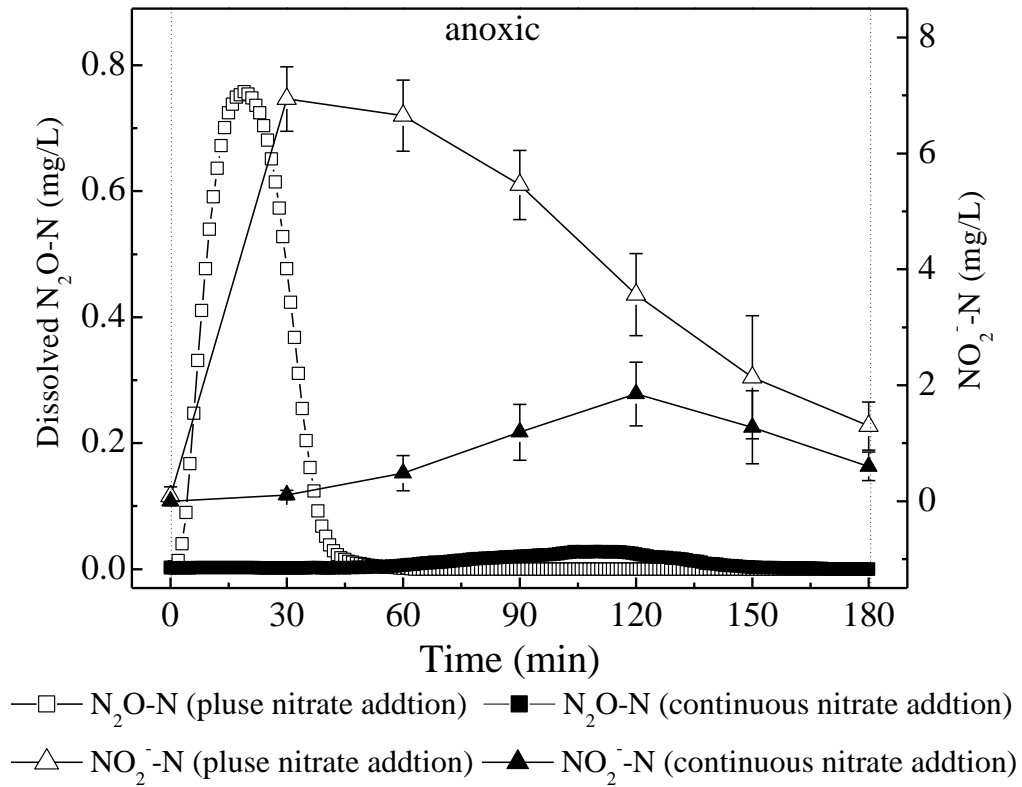

Fig. 6. N_2O generation and NO_2^-N accumulation profiles during two batch experiments with the pulse and continuous feed strategies. Error bars represent standard deviations of triplicate tests.

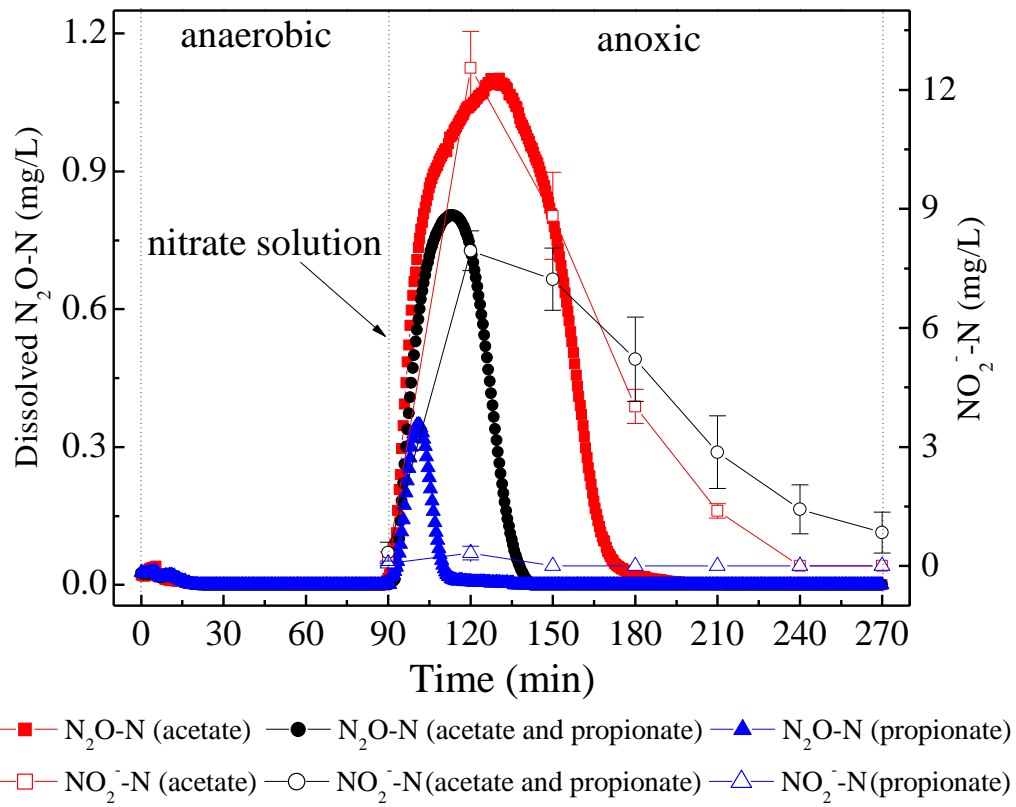

Fig. 7. N₂O generation and NO₂⁻-N accumulation profiles during three batch experiments with acetate alone, the mixture of acetate and propionate or propionate alone as carbon source. Error bars represent standard deviations of triplicate tests.



Minerva Access is the Institutional Repository of The University of Melbourne

Author/s:

Li, C;Zhang, J;Liang, S;Ngo, HH;Guo, W;Zhang, Y;Zou, Y

Title:

Nitrous oxide generation in denitrifying phosphorus removal process: main causes and control measures

Date:

2013-08

Citation:

Li, C., Zhang, J., Liang, S., Ngo, H. H., Guo, W., Zhang, Y. & Zou, Y. (2013). Nitrous oxide generation in denitrifying phosphorus removal process: main causes and control measures. ENVIRONMENTAL SCIENCE AND POLLUTION RESEARCH, 20 (8), pp.5353-5360. <https://doi.org/10.1007/s11356-013-1530-3>.

Persistent Link:

<http://hdl.handle.net/11343/282861>