

Title: Habitat connectivity, more than species' biology, influences genetic differentiation in a habitat specialist, the short-eared rock-wallaby (*Petrogale brachyotis*)

Authors: Sally Potter^{1,2}, Mark D.B. Eldridge^{2,3}, Steven J.B. Cooper^{1,4}, Justyna Z. Paplinska⁵, David A. Taggart^{1,6}

¹School of Earth & Environmental Science and Australian Centre for Evolutionary Biology and Biodiversity, University of Adelaide, SA 5005, Australia, ²Molecular Biology, Australian Museum, NSW 2010, Australia, ³Department of Biological Sciences, Macquarie University, NSW 2109, Australia, ⁴Evolutionary Biology Unit, South Australian Museum, SA 5000, Australia, ⁵Zoology Department, The University of Melbourne, Victoria 3010, Australia, ⁶Conservation Ark, Royal Zoological Society of South Australia, SA 5000, Australia.

Emails:

Sally Potter (sally.potter@austrmus.gov.au)

Mark D. B. Eldridge (mark.eldridge@austrmus.gov.au)

Steven J. B. Cooper (steve.cooper@samuseum.sa.gov.au)

David A. Taggart (david.taggart@adelaide.edu.au)

Justyna Z. Paplinska (Justyna.Paplinska@abares.gov.au)

Corresponding Author:

Sally Potter

Present Address: Australian Museum, 6 College Street, Sydney, NSW 2010, AUSTRALIA

Email: sally.potter@austrmus.gov.au

1 **Abstract**

2 It is difficult to assess the relative influence of anthropogenic processes (e.g. habitat fragmentation)
3 versus species' biology on the level of genetic differentiation among populations when species are
4 restricted in their distribution to fragmented habitats. This issue is particularly problematic for Australian
5 rock-wallabies (*Petrogale* sp.), where most previous studies have examined threatened species in
6 anthropogenically fragmented habitats. The short-eared rock-wallaby (*Petrogale brachyotis*) provides an
7 opportunity to assess natural population structure and gene flow in relatively continuous habitat across
8 north-western Australia. This region has reported widespread declines in small-to-medium sized
9 mammals, making data regarding the influence of habitat connectivity on genetic diversity important for
10 broad-scale management. Using non-invasive and standard methods, 12 microsatellite loci and
11 mitochondrial DNA were compared to examine patterns of population structure and dispersal among
12 populations of *P. brachyotis* in the Kimberley, Western Australia. Low genetic differentiation was
13 detected between populations separated by up to 67 km. The inferred genetic connectivity of these
14 populations suggests that in suitable habitat *P. brachyotis* can potentially disperse far greater distances
15 than previously reported for rock-wallabies in more fragmented habitat. Like other *Petrogale* species
16 male-biased dispersal was detected. These findings suggest that a complete understanding of population
17 biology may not be achieved solely by the study of fragmented populations in disturbed environments and
18 that management strategies may need to draw on studies of populations (or related species) in undisturbed
19 areas of contiguous habitat.

20

21 **Keywords:** *Petrogale brachyotis*; rock-wallaby; mitochondrial DNA; microsatellites; habitat
22 connectivity; genetic diversity.

1 **Introduction**

2

3 Habitat fragmentation is a major threat to global biodiversity through its negative impacts, both direct and
4 indirect, on population dynamics (Fahrig 2003; Frankham et al. 2010; Gilpin and Hanski 1991; Harris
5 1984). Fragmentation (loss of habitat and connectivity) prevents or reduces dispersal, restricts gene flow
6 and results in increased genetic drift (fixation and loss of alleles) and thus genetic differentiation among
7 populations (Frankham et al. 2010; Lacy 1987; Lancaster et al. 2011; Stow and Sunnucks 2004). As well
8 as reduced diversity, fragmentation can also lead to increased inbreeding, due to reduced dispersal and
9 limited mate choice, and therefore inbreeding depression (Banks et al. 2005; Frankham et al. 2010). This
10 results in populations with reduced fitness and adaptability and so increases their risk of extinction
11 (Frankham et al. 2004, 2010).

12

13 Landscape characteristics alone, however, do not determine population structure, since individual species'
14 biology will also contribute to the extent of differentiation between populations (Brouat et al. 2003;
15 Kraaijeveld-Smit et al. 2007; Meyer et al. 2009; Öckinger et al. 2010). Life-history traits including
16 dispersal ability and sex-biased dispersal, mating system, habitat specialisation and generation time, all
17 impact population dynamics and the distribution of genetic diversity (Ewers and Didham 2006; Hedrick
18 2000; Henle et al. 2004; Prugh et al. 2008; Slatkin 1994). Even in continuous habitat these factors alone
19 can lead to genetic differentiation (Cabe et al. 2007; Hazlitt et al. 2006a; Kraaijeveld-Smit et al. 2007). It
20 can, therefore, be difficult to separate the effects of life-history traits from those of habitat fragmentation
21 when assessing population structure. In addition, investigating the factors that influence population
22 differentiation in contiguous habitat provides insight into genetic structure prior to the impacts of
23 fragmentation (Macqueen et al. 2008). Comparison of genetic connectivity between populations within
24 continuous and fragmented landscapes often reveal large differences attributed to anthropogenic
25 processes (Stow et al. 2001). Fragmented populations may not solely result from habitat fragmentation,
26 since other factors such as resource availability, climatic conditions, presence of competitors and
27 predators can also limit the spatial distribution of species (Fischer et al. 2005). Genetic studies can be
28 valuable in identifying the impact of anthropogenic processes and so enable better informed conservation
29 management decisions (Lindenmayer and Fischer 2006).

1
2 The impacts of fragmentation versus life-history processes have rarely been investigated in mammals, yet
3 are fundamental to understanding the factors that influence population declines (Amos and Balmford
4 2001; Peacock and Smith 1997; Walker et al. 2008; Wolff et al. 1997). To date, population genetic studies
5 of rock-wallabies (*Petrogale* spp.) have focused on threatened and highly fragmented populations in
6 southern Australia, including the yellow-footed (*P. xanthopus*), brush-tailed (*P. penicillata*) and black-
7 footed (*P. lateralis*) rock-wallabies (Browning et al. 2001; Eldridge et al. 1999, 2001; Hazlitt et al. 2006a;
8 Piggott et al. 2006a; Pope et al. 1996). These rock-wallabies are now mostly present in small, isolated
9 colonies with limited dispersal and gene flow between them (Hazlitt et al. 2004, 2006a; Jarman and
10 Bayne 1997). Rock-wallabies appear to have lower genetic diversity within populations and higher
11 genetic divergences between populations compared to other macropodoids (Eldridge et al. 2010). This has
12 been linked to their habitat specificity (i.e. rocky outcrops and escarpments) and therefore naturally
13 patchy distribution (Eldridge et al. 2010; Hazlitt et al. 2006a; Piggott et al. 2006a). However, this
14 assumption may be flawed (Eldridge et al. 2010), with these studies being biased towards rock-wallaby
15 species that have declined as a result of habitat clearance/fragmentation and the impact of introduced
16 predators (Maxwell et al. 1996). Additional analyses of rock-wallabies in more continuous habitat would
17 elucidate whether this apparent low diversity is a function of species' biology or a result of anthropogenic
18 processes.

19
20 The widespread and abundant short-eared rock-wallaby (*P. brachyotis*) from northern Australia (Fig. 1)
21 provides a good candidate to examine the effects of life-history strategies versus anthropogenic processes
22 within rock-wallabies. A recent study of *P. brachyotis* in the Northern Territory, northern Australia,
23 aimed to assess population structure in more continuous habitat, but nevertheless revealed highly
24 structured populations (Telfer and Eldridge 2010). This study suggests that rock-wallabies are
25 predisposed to being highly structured as a result of their strong association with rocky habitat. Even
26 though the Northern Territory retains largely intact vegetation between populations of *P. brachyotis*, the
27 sandstone gorges and outcrops, which represent core rock-wallaby habitat (sampled by Telfer and
28 Eldridge 2010), were quite disjunct and this seems likely to have led to the highly structured genetic
29 diversity found in this species. The Kimberley, in northern Western Australia differs from the areas

1 sampled by Telfer and Eldridge (2010) in that it contains not only more extensive dissected sandstone
2 plateaus and ranges, but also greater connectivity of rocky habitat, with less separation of these broader
3 sandstone habitats across the landscape (Fig. 1). Therefore, this landscape provides an opportunity to
4 assess the population biology of a rock-wallaby within intact and more continuous rocky habitat. A recent
5 broad-scale phylogeographic study of *P. brachyotis* found high levels of genetic differentiation between
6 the Kimberley and Top End, as well as identifying three distinct lineages within the Kimberley (Potter et
7 al. 2012a). Although the Kimberley is relatively unaffected by the threatening processes, described above,
8 which have impacted eastern and southern parts of Australia, widespread declines of small-to-medium
9 sized mammals have recently been reported (Fitzsimons et al. 2010). It is therefore important to assess the
10 population biology of taxa in this region, to better understand the influences of landscape on genetic
11 differentiation. *P. brachyotis* in this region could also provide a suitable reference for the genetic diversity
12 and population structure of a pre-decline or 'healthy' population of rock-wallaby, which could be used to
13 set appropriate goals for the management of declining and threatened populations of rock-wallabies
14 throughout Australia (Eldridge et al. 2004a), as well as declining mammals in northern Australia.

15

16 Rock-wallabies occur in small colonies (~5-100 individuals) and show high site fidelity (Eldridge 2008).
17 Studies of rock-wallaby mating system and life-history are limited and there are no data for *P. brachyotis*,
18 however, available evidence suggests sex-biased dispersal and strong female philopatry results in
19 inbreeding avoidance and maintains genetic diversity (Pope et al. 1996; Hazlitt et al. 2004, 2006b, 2010,
20 Piggott et al. 2006a). Despite limited inter-colony gene flow, intra-colony genetic diversity appears to be
21 maintained via kin avoidance and mating dispersal (Spencer et al. 1997; Hazlitt et al. 2006b).

22

23 The current study uses trapping and non-invasive methods to investigate the genetic diversity and fine-
24 scale population structure of *P. brachyotis* across the Kimberley to determine the effects of continuous
25 versus fragmented habitat on population biology. The aims were to use microsatellite genotypes and
26 mtDNA sequences to: (i) assess genetic diversity and population differentiation of *P. brachyotis* in a
27 relatively connected environment versus two fragmented island populations, and (ii) investigate life-
28 history strategies within *P. brachyotis* (e.g., sex-biased dispersal) to assess the impact of fragmentation on
29 these processes.

1
2
3
4
5
6
7
8
9
10
11
12
13
14
15
16
17
18
19
20
21
22
23
24
25
26
27
28
29

Materials and methods

Study site and sample collection

Samples were collected from six sites (March 2007 – August 2010) within the Kimberley region of northwest Australia (Fig. 1). Four sites were sampled from the relatively intact environment of the northwest Kimberley (West Kimberley) over a hierarchical spatial scale from ~1 km to 67 km apart (Table 1; Fig. 1). In addition, two isolated populations located on islands in Lake Argyle in the East Kimberley were sampled (~3.5 km apart). These islands were formed in 1972 when the Ord River was dammed creating Lake Argyle. The East and West Kimberley sites were ~290 km apart (Fig. 1) and span the three distinct lineages identified by Potter et al. (2012a) within the Kimberley (West Kimberley-WK; East Kimberley-1, EK1; and East Kimberley-2, EK2) (see Table 1).

A total of 84 *P. brachyotis* (51 tissue and 33 fecal) samples were analysed. One *P. penicillata* (brush-tailed rock-wallaby) was used as an outgroup for phylogeographic analyses (see Potter et al. 2012b). Tissue samples (ear biopsies) were obtained from live-trapped *P. brachyotis* from four sites (Couchman-CN, Cyprus Valley-CV, Monsmont Island-MI and Bullanyin Island-BI; Fig. 1). For the purposes of the population analyses all samples were pooled over years, because major changes in allele frequencies between years are unlikely due to the long life-span of rock-wallabies (e.g., up to 12 years; Bee and Close 1993). Rock-wallabies inhabit rugged terrain (Van Dyck and Strahan 2008) and in the Kimberley access is limited, therefore 33 fresh faecal samples were collected to supplement tissue samples. Fresh faeces were collected from three sites (CN, King Edward River-KER, Pump Hill-PH; Fig. 1), individually stored in brown paper envelopes and kept frozen at -20°C from the day of collection until processing. The sample sizes for each of the six populations do not necessarily correlate to population density, but were based on sample availability and PCR success.

DNA extraction, amplification, microsatellite genotyping and mtDNA sequencing

1
2 Genomic DNA was isolated from tissue samples using the Genra DNA Isolation Kit (Genra Systems)
3 and from faecal samples using the QIAamp DNA Stool Kit (QIAGEN), according to the manufacturer's
4 instructions and the method of Piggott and Taylor (2003) with modifications (see Supplementary
5 Material).

6
7 Polymerase chain reaction (PCR) was used to amplify two mitochondrial gene segments from tissue
8 samples; *CR* (control region), L15999M (5'-ACCATCAACACCCAAAGCTGA-3') and H16498M (5'-
9 CCTGAAGTAGCAACCAGTAG) (Fumagalli et al. 1997); *ND2* (NADH dehydrogenase subunit 2),
10 mmND2.1 (5'-GCACCATTCCACTTYTGAGT-3') and mrND2c (5'-
11 GATTTGCGTTTCGAATGTAGCAAG-3') (Osborne and Christidis 2001). PCR-amplifications were
12 carried out in 25µL reactions with ~100ng genomic DNA, 1 x PCR buffer (Applied Biosystems),
13 0.20mM dNTPs, 2.5mM MgCl₂, 2 pmol primers and 0.1 U *AmpliTaq Gold*TM polymerase (Applied
14 Biosystems). Thermocycling conditions were: initial denaturation at 94°C for 9 min; 34-40 cycles of 45
15 sec at 94°C (denaturation), 45 sec at 48°C (*ND2*)/55°C (*CR*) (annealing), and 1 min at 72°C (extension);
16 and a final extension for 6 min at 72°C. PCR products were purified using Millipore MultiScreen PCR₃₈₄
17 Filter Plates (Millipore) and directly sequenced on an AB 3730xl DNA Analyzer (Applied Biosystems) at
18 the Australian Genome Research Facility (AGRF).

19
20 All individuals were screened with a total of 12 polymorphic microsatellite loci: Pa297, Pa593, Pa597
21 from the allied rock-wallaby (*P. assimilis*; Spencer et al. 1995); Me2, Me14, Me15, Me16, Me17 from the
22 tammar wallaby (*Macropus eugenii*; Taylor and Cooper 1998); Y76, Y148, Y170 from *P. xanthopus*
23 (Pope et al. 1996); G26-4 from the eastern-grey kangaroo (*M. giganteus*; Zenger and Cooper 2001). In
24 addition, an SRY male-specific marker from *P. penicillata* (O'Neill et al. 1997) was used to sex the
25 faecal samples.

26
27 Primer mixes (PM) consisted of 1µL of each fluorescently labelled primer (100µM) in 25µL volumes in
28 the following combinations: PM1 – Y170, Pa297, Pa593; PM2 – Y148; PM3 – Y76, Me15; PM4 – SRY;
29 PM5 – Me17, Me2; and PM6 – Pa597, Me14, Me16, G26-4.

1
2 PCR-amplifications of tissue samples were carried out in 10µL reaction volumes following the methods
3 of Miller et al. (2010) using a Multiplex PCR kit (Qiagen); with approximately 30ng genomic DNA, 5µL
4 Multiplex MasterMix, 0.1mM BSA, 0.2µM of each primer,. Thermocycling conditions were: initial
5 denaturation at 95°C for 15 min; 34-50 cycles of 30 s at 94°C (denaturation), 90 s at 58°C (Primer Mix 1,
6 PM 2, PM4), 56°C (PM3) and touchdown 60-50°C (60°C, 57°C, 55°C, 52°C and 50°C for 10 cycles
7 each; PM 5) (annealing), and 90 s at 72°C (extension); and a final extension for 10 min at 72°C. PCRs
8 were pooled: Pool 1 included 4µL PM 1, 3µL PM 2, 4µL PM 3, and 4µL PM 4; and Pool2 included 4µL
9 PM5, 4µL PM6. Pooled PCR products were cleaned using Millipore MultiScreen PCR₃₈₄ Filter Plates
10 (Millipore) following the manufacturer's protocols. Serial dilutions of 1:40 for Pool 1 and 1:20 for Pool 2
11 were then genotyped at the Australian Genome Research Facility (AGRF) with an automated ABI 3730xl
12 capillary sequencer (Applied Biosystems).

13
14 Multiplex PCR-amplifications of faecal samples were carried out in 25µL reactions using the Qiagen
15 Multiplex kit (Qiagen); with 15µL Multiplex MasterMix, 2.5µL Q solution, 0.2µM of each primer and
16 2µL of DNA extract. The following conditions were used for amplification: initial denaturation 94°C for
17 5 min; 50 cycles of 30 s at 94°C (denaturation), 30 s at 56°C (PM 1 and 3), 54°C (PM2) and touchdown
18 60-54°C (60°C, 58°C, 56°C for 10 cycles each, 54°C for 20 cycles ; PM 4-6) (annealing), and 30 s at
19 72°C (extension); and a final extension for 30 min at 72°C. Primer mixes PM1 and PM3 were pooled
20 together, as were primer mixes PM4, PM5 and PM6 into two separate MultiMix PCR reactions unlike the
21 individual PCRs used for the tissue samples. PCR samples were pooled as above and then 1µL of pooled
22 product was added to 0.3µL Liz500 and 8.7µL Hi-Di for genotyping and analysed on a 3730 DNA
23 Analyser (Applied Biosystems).

24
25 DNA from non-invasive techniques can produce yields with lower quality and quantity. We, therefore,
26 replicated all PCRs three times, according to Piggott et al. (2006b), to control for allelic dropout
27 (stochastic non-amplification of one allele), the occurrence of false alleles and ensure reduction in type 1
28 errors (novel genotypes which are incorrect). The microsatellite DNA fragments were scored using
29 GENEMAPPER v4.0 (Applied Biosystems) for allele size and quantification. To ensure duplicate samples

1 of faecal DNA or samples from trapped animals were not included in the analysis, only unique multilocus
2 genotypes were used for population analyses. Following Piggott et al. (2006b) we accepted a
3 heterozygous genotype if each allele was present in two out of three replicates and only accepted a
4 homozygous allele if only one allele was identified in all three replicates. A *post hoc* method was
5 implemented, whereby samples that matched at all but four alleles were assigned the same identity (one
6 individual removed from further analyses). This approach aims at eliminating overestimation biases of
7 population abundance because the probability of individuals differing at two or more loci was high
8 (Ruibal et al. 2009). Allelic dropout and false alleles were estimated for each microsatellite locus and
9 sample using GIMLET (v3.2; Valière 2002), with total number of positive amplifications and genotyping
10 errors per locus and sample computed. Following the methods of Ruibal et al. (2009), the frequencies of
11 allelic dropout were then used to estimate a locus-specific rate using the equations ADO_l from Broquet
12 and Petit (2004).

13

14 *Population genetic and phylogenetic analyses*

15

16 Mitochondrial DNA sequences were edited using SeqEd (version 1.0.3; Applied Biosystems), then
17 aligned using CLUSTAL X (version 1.83; Thompson et al. 1997) and manually refined using SeAl (version
18 2.0a11; Rambaut 1996). DNASP (v5.10; Librado and Rozas 2009) was implemented to estimate the
19 number of haplotypes (H), polymorphic sites, nucleotide diversity (π) and haplotype diversity (h) (Rozas
20 et al. 2003). Intra-specific sequence divergence among mtDNA haplotypes was estimated for the
21 combined mtDNA dataset with PAUP* (v4.0b10; Swofford 2002) using the Kimura 3-parameter model
22 (Kimura 1981) selected by MODELTEST 3.06 (Posada and Crandall 1998), based on the Akaike
23 Information Criterion (AIC).

24

25 Conformance to Hardy-Weinberg equilibrium and linkage disequilibrium for each microsatellite locus
26 within each population was assessed using GENEPOP (v3.2; Raymond and Rousset 1995) employing the
27 Markov chain method with 1000 iterations and P -values adjusted using the sequential Bonferroni
28 procedure (Rice 1989). The presence of null alleles was estimated using MICRO-CHECKER (v2.2.3; Van
29 Oosterhout *et al.* 2004). Allelic diversity (AD ; average number of alleles per locus), observed and

1 expected heterozygosity (H_O , H_E respectively) were calculated for each population in ARLEQUIN (v3.11;
2 Excoffier et al. 2005), and allelic richness (AR ; allelic diversity corrected for sample size) was estimated
3 using FSTAT (v2.9.3; Goudet 1995). Differences in H_E , AD and AR between the populations were tested
4 using a Wilcoxon signed rank test with loci as the pairing factor using PASW Statistics, Release Version
5 17.0.2 (SPSS, Inc.). The number of rare alleles (frequency $\leq 5\%$) and the number of unique alleles (A_U)
6 were calculated in GenAlEx 6 (Peakall and Smouse 2006).

7
8 Multilocus F_{IS} was also calculated at each locus for each population using FSTAT (version 2.9.3; Goudet
9 1995), and then tested by 1000 permutations using Weir and Cockerham's estimator (Weir and
10 Cockerham 1984) an analogue of Wright's F statistic (F_{IS} ; Wright 1951). F_{IS} was also calculated for
11 males and females individually for each population.

12 13 *Genetic structure*

14
15 To assess whether individuals sampled at specific localities represent discreet genetic populations,
16 STRUCTURE 2.1 (a Bayesian clustering method; Pritchard et al. 2000) was used to infer population
17 structure. This method assumes no *a priori* geographical information and uses genotype data to infer
18 population groups that minimise Hardy-Weinberg equilibrium and linkage disequilibrium. Analyses were
19 performed on the entire microsatellite dataset and then on separated East and West Kimberley samples to
20 identify any subtle structure between the sampling areas which may have been overlooked in the broader
21 analysis. We estimated the most likely number of genetic clusters/groups (K) from between one to six for
22 the entire dataset (total number of sampled sites), one to four for the West Kimberley samples and one to
23 three for the East Kimberley samples (minimum three populations required for ΔK assessment below).
24 The parameters used were the admixture ancestry model, correlated allele frequencies model, a burnin
25 length of 10 000 iterations and a run length of 100,000 Markov chain Monte Carlo repetitions, with 6
26 iterations of each K . To estimate K , $\ln P(X|K)$ (log likelihood value of K given the genotypes of sampled
27 individuals, X) and ΔK values (a measure of the second order rate of change in the likelihood of K ;
28 Evanno et al. 2005) were assessed, with the lowest log likelihood value and highest ΔK value
29 representing the most likely K (Pritchard et al. 2000).

1
2 An analysis of molecular variance (AMOVA based on Wright's F statistic F_{ST} ; Wright 1951) was carried
3 out in ARLEQUIN (v3.11; Excoffier et al. 2005) to examine the extent of population structuring, assessing
4 mtDNA differentiation (pairwise Φ_{ST}) amongst the four populations from which tissue samples were
5 collected (based on 10 000 permutations) and microsatellite differentiation (pairwise F_{ST} ; Wright 1951)
6 among all six populations (based on 10 000 permutations). To visualise genetic differentiation among the
7 six populations we used the microsatellite data to generate an unrooted neighbour-joining (NJ) tree based
8 on Nei's standard genetic distance (Ds; Nei 1972) and 1000 bootstrapping support over individuals using
9 the program POPULATIONS 1.2.32 (Langella 1999).

10
11 Concordance of the two mitochondrial fragments was assessed by independently generating phylogenetic
12 trees for both *CR* and *ND2* to ensure concatenation of the data was appropriate. Maximum likelihood
13 (ML), maximum parsimony (MP) and Bayesian inference analyses were performed on the concatenated
14 mitochondrial alignment of *CR* and *ND2* using RAxML (v7.0.3; Stamatakis 2006; Stamatakis et al.
15 2008), PAUP* (v4.0b10; Swofford 2002) and MRBAYES (v3.1.2; Huelsenbeck and Ronquist 2005;
16 Ronquist and Huelsenbeck 2003) respectively. The program MODELTEST 3.06 (Posada and Crandall
17 1998) in PAUP* (v4.0b10) was used to determine the best-fit models, based on the AIC. Results from all
18 analyses gave similar overall topologies, therefore only ML results are included. As the exact model
19 suggested from MODELTEST 3.06 was not available in RAxML, the more complex General time
20 Reversible (GTR) model was applied, with rate variation among sites modelled with a discrete gamma
21 distribution (G), helping to account for rate variation among the non-coding *CR* and codon positions of
22 *ND2*. Analysis used a random starting tree and bootstrap analyses were carried out for 1000 replicates,
23 with multiple (100) searches per replicate, using the rapid Bootstrap analysis.

24
25 We tested for correlation (r) between genetic (microsatellite data) distance (Nei's D_A ; Nei et al. 1983) and
26 geographical distance using Mantel tests (Mantel 1967) implemented in AIS (Alleles in Space; Miller
27 2005) for all locations, for males and females individually and for the West Kimberley individuals alone,
28 based on 1000 permutations and 10 distance classes.

29

1
2
3
4
5
6
7
8
9
10
11
12
13
14
15
16
17
18
19
20
21
22
23
24
25
26
27
28
29

Estimation of dispersal patterns using assignment tests

Putative first generation migrants and their population of origin were identified using the program GENECLASS 2.0 (Piry et al. 2004). Using the Bayesian method of Rannala and Mountain (1997) the likelihood of each genotype in each population was estimated, following the Paetkau et al. (2004) Monte Carlo re-sampling method. We used the comparison of the likelihood of each individual in its ‘home’ (sampled) population to the most likely of the other sampled populations, but took into account that all possible populations were not sampled ($L=L_{home}$). Individuals that were significantly different from their sampled population were only assigned to another population as the ‘home’ if the significance was above 0.99. Immigrants that did not meet the P value of 0.99 were considered immigrants from unsampled colonies. Methods followed Piggott et al. (2006a) and despite the small sample sizes for some populations, using the Bayesian method, with more than 10 loci, and F_{ST} values close to 0.1 or greater between populations, the procedure should be quite accurate (Cornuet et al. 1999; Paetkau et al. 2004). Putative migrants were checked for concordance with Bayesian clustering results of STRUCTURE 2.1.

Relatedness within populations

Individuals in each population were examined for overall pairwise relatedness and sex-specific relatedness using the program GenAlEx 6 (Peakall and Smouse 2006). Pairwise relatedness (r) estimates were calculated using the method of Queller and Goodnight (1989). An average of pairwise relatedness within populations was estimated using GenAlEx 6 using the Pops Mean option with 9999 permutations and 9999 bootstraps to estimate the 95% confidence interval around r . This was used to test the assumption that the average pairwise relatedness values did not differ significantly from random assortments of relatedness values (unrelated individuals).

Results

1 *Genetic diversity*

2

3 A total of 1182 base pairs (bp) of mtDNA was analysed (596 bp *CR*; 586 bp *ND2*) from 52 individuals
4 (30 females, 21 males; and one *P. penicillata*). GenBank accession numbers are given in Table 1. Within
5 the mtDNA fragment 120 sites were variable, of which 116 sites were parsimony informative. Within the
6 *CR*, seven different indels were detected within *P. brachyotis*. Thirteen mtDNA haplotypes were
7 identified (Table 1), with haplotype and nucleotide diversity highest in CV ($h=52.6\%$, $\pi=0.77\%$; Table 2).

8

9 A total of 40 females and 44 males (23 identified from faecal samples using the SRY marker) were
10 genotyped for the six populations (see Supplementary Table 1 for genotypes). All microsatellite loci in
11 each population conformed to Hardy-Weinberg equilibrium after sequential Bonferroni corrections,
12 except for PH which revealed a significant heterozygote deficit at one locus (Pa597). There was
13 significant linkage disequilibrium after sequential Bonferroni corrections only within KER between the
14 following sets of loci: Me14/Y148, Me15/Y148, Me14/Me15, Me15/Pa593, Pa297/Y76, Pa593/Y148. All
15 other populations examined revealed linkage equilibrium, so analyses were carried out on the full dataset.
16 No false alleles were detected, but 23 allelic differences were identified of the 1188 faecal amplifications,
17 giving a genotyping error rate of 1.9%. The amplification success rate was 84% for both loci and samples,
18 with allelic dropout rates of 2.8% detected across samples and 3.5% across loci.

19

20 The average number of alleles detected per locus was 6.13 ± 2.24 . East Kimberley populations (MI and
21 BI) had significantly lower *AD* values compared to West Kimberley populations (CN, CV, PH; *AD* = 4.1-
22 4.3 vs. 6.3-8.3, $P<0.05$; Table 2). When corrected for sample size (*AR*), MI was significantly lower
23 compared to three of the West Kimberley populations (*AR* = 3.6 vs. 5.3-5.6, $P<0.05$; Table 2), whereas BI
24 was only significantly lower when compared to PH (H_E and *AR*; $H_E = 0.661$ vs. 0.771, *AR* = 4.4 vs. 5.4;
25 $P<0.05$; Table 2). The West Kimberley H_E , *AD* and *AR* values were not significantly different between
26 populations ($P>0.05$) except for *AD* between CN and KER (Table 2). No significant inbreeding (F_{IS}) was
27 detected for any population at any locus ($P>0.05$), or for males or females within populations (Table 2).
28 No rare alleles (frequency $\leq 5\%$) were detected. Unique alleles were detected in all populations ranging

1 from 1% (KER, PH) to 7% (BI; Table 2). A total of 71 alleles (48%) were only found in the West
2 Kimberley populations and 25 alleles (17%) were unique to the East Kimberley populations.

3

4 *Genetic structure*

5

6 Initial STRUCTURE results for all the microsatellite data indicated a geographically distinct East and West
7 Kimberley grouping ($K = 2$), with all individuals assigned to each cluster at probabilities >0.9 . However,
8 when the East and West Kimberley genetic clusters were analysed separately, the ΔK value was highest
9 for two in East Kimberley analysis ($K = 2$) and two in the West Kimberley analysis ($K = 2$), indicating
10 more subtle structure within these smaller regions (Fig. 2). Within the West Kimberley analysis, not all
11 individuals were assigned to a cluster (probabilities >0.8), with sixteen individuals having a mixed
12 assignment (probabilities <0.8) and three individuals (CN17, KER09, CN29) clustering with a group
13 different to those corresponding to their sampling region (see Fig. 2). Generally, one cluster consisted of
14 individuals from CN and KER, and the second cluster of individuals from CV and PH (Fig. 2). The East
15 Kimberley assignments corresponded to the sampled localities of the two islands in Lake Argyle, with
16 only one individual not assigned to a cluster (MI10; Fig. 2).

17

18 Population differentiation (Φ_{ST}) in mtDNA was highly significant between the four analysed populations
19 (CV, MI, BI, CN) with values ranging from 0.856 to 0.995 (Table 3). For the purposes of looking at fine-
20 scale genetic structure within the West Kimberley, we employed all four sites from this region as separate
21 populations for analysis. All microsatellite pairwise population comparisons (F_{ST}) were significant after
22 sequential Bonferroni corrections, excluding CV vs. PH (0.022-0.059; Table 3). The range of F_{ST} values
23 between the East and West Kimberley populations and between the two East Kimberley populations were
24 orders of magnitude higher ($F_{ST}=0.184-0.274$; $F_{ST}=0.166$ respectively; Table 3).

25

26 The unrooted NJ tree based on Ds between the six populations reveals closer genetic distances between
27 the West Kimberley populations than those between the East Kimberley populations or between the East
28 and West Kimberley (see Fig. 3). Bootstrap values (87-91%) provide strong support for more closely
29 related populations in the West Kimberley.

1
2 The *CR* and *ND2* produced the same topology in independent phylogenetic analyses therefore only
3 concatenated results are discussed. Three distinct groupings of haplotypes were apparent from the
4 phylogenetic analyses (Fig. 4). One lineage comprised the haplotypes from MI (H, I, J), with the second
5 lineage consisting of haplotypes from BI (K, L, M). The remaining haplotypes (A–G) from the CN and
6 CV (West Kimberley) formed the third monophyletic group, with 0.2-2.9% sequence divergence (SD)
7 between haplotypes (0.2-0.3% SD amongst haplotypes from CN; 0.4-2.9% SD CV). Between the
8 fragmented MI and BI there was 5.6-5.9% SD.

9
10 Mantel tests indicated significant correlations of both male and female genetic divergence and geographic
11 distances ($P < 0.05$) across the Kimberley, with females having a slightly higher correlation of genetic
12 similarity to geographic distance ($r = 0.73$ females; $r = 0.68$ for males). Results for the West Kimberley
13 alone revealed significant, yet far lower, correlations between genetic and geographic distances ($r = 0.30$,
14 $P < 0.05$), with slightly greater genetic similarity to geographic distance for females ($r = 0.36$, $P < 0.05$) than
15 for males ($r = 0.25$, $P < 0.05$).

16
17 *Estimation of dispersal patterns using assignment tests*

18
19 Four putative immigrants were detected amongst the six sites using GENECLASS 2.0, including
20 individuals from CN, MI, KER and PH (CN29, MI10, KER09 and PH11 respectively). No first
21 generation female immigrants were detected, with all four of these potential dispersers being males. Two
22 individuals (CN29 and KER09) had the highest likelihoods of coming from PH and PH11 had the highest
23 likelihood of coming from KER, but these individuals were not assigned to any population with a
24 probability of 0.99. MI10, however, was excluded from all populations with no other sampled population
25 having a higher likelihood of being 'home' despite the individual not having a high enough probability
26 (0.99) of belonging to its 'home' population. Since all four individuals could not be assigned to a
27 population with high probability (0.99) it is likely they have originated from sites not sampled in this
28 study.

29

1 *Relatedness within populations*

2

3 All pairwise intra-population means showed that males and females were significantly related ($P < 0.05$).

4 KER and PH appeared to have less significant relatedness, with bootstrap analysis indicating some

5 overlap with the permuted relatedness values of the null hypothesis (unrelated individuals; results not

6 shown). Females were significantly related (significant r means for intra-population analyses; $P < 0.05$) for

7 all sites except PH, whereas males were significantly related except at CV ($P < 0.05$; Fig. 5).

8

9

10 **Discussion**

11

12 While both habitat fragmentation and species' biology can influence population biology, our study has

13 demonstrated that for *P. brachyotis* habitat connectivity plays a critical role in maintaining gene flow and

14 reducing genetic differentiation across the landscape. Numerous *Petrogale* taxa have declined in Australia

15 and their remnant populations are actively managed (DEH 2006; DECC 2008; DERM 2010; Read and

16 Ward 2010). The effects of fragmentation versus life-history traits on population biology in these species

17 are unknown, since they now form small, isolated colonies and were not studied prior to their decline.

18 Similar situations occur across the world, where limited information exists for species prior to their

19 decline. Management of such taxa can be difficult without knowledge of natural pre-decline population

20 dynamics and since such processes can be disturbed by fragmentation (e.g. Smith and Hellmann 2002),

21 management can draw on studies of abundant closely related taxa in unmodified landscapes. This study

22 provides the first comparison of rock-wallaby populations in a landscape containing large areas of

23 interconnected habitat. For *P. brachyotis* genetic differentiation appears not to be a function of species'

24 biology alone, highlighting the importance habitat connectivity plays in maintaining gene flow and

25 reducing differentiation. This highlights that a detailed understanding of population biology may not

26 solely be achieved by the study of fragmented populations in disturbed environments and that

27 management strategies may need to draw on studies of related species in undisturbed areas of contiguous

28 habitat.

29

1 *Effects of Habitat*

2

3 The greater habitat connectivity across the West Kimberley was associated with lower genetic
4 differentiation within *P. brachyotis* compared to individuals from the island populations in the East
5 Kimberley. The relatively low levels of genetic differentiation (F_{ST} values; 0.027-0.059) found at
6 distances of up to 67 km are in contrast to those reported for rock-wallaby populations in closer proximity
7 using similar combinations of microsatellite loci, but within more heavily modified landscapes; including
8 *P. penicillata* ($F_{ST}=0.072$, <10km; Hazlitt et al. 2006a), *P. xanthopus* ($F_{ST}=0.107$, 10-70 km; Pope et al.
9 1996) and *P. lateralis* ($F_{ST}=0.238$, <10 km; Eldridge et al. 2001). They are also far lower than that found
10 in *P. brachyotis* from the Northern Territory which had limited contemporary and long-term gene flow
11 between populations 1.2 km apart ($F_{ST}: 0.085$; Telfer and Eldridge 2010). In comparison, CV and PH,
12 ≈ 1.2 km apart did not show significant genetic differentiation ($F_{ST}: 0.022$). Three first generation
13 migrants were detected in the West Kimberley, indicating gene flow is occurring across this landscape,
14 however, these immigrants are likely to have come from unsampled populations and further assessment of
15 population and home range sizes may identify at what level fine-scale population structure exists at this
16 location. The phylogenetic results of mtDNA provide no evidence for long term isolation of females
17 between sites in the West Kimberley. Haplotypes from CV and CN formed a monophyletic group with
18 only 0.2-2.9% SD compared to the two island populations which had 5.6-5.9% SD and formed two
19 independent monophyletic groups. Although the similarity between sites in the West Kimberley could be
20 interpreted as retained ancestral polymorphisms, the F_{ST} data, close genetic distances between
21 populations and STRUCTURE results (showing two genetic clusters connected at distances up to 18 km,
22 numerous individuals with admixed ancestry ($\sim 24\%$) and three individuals grouping with the genetic
23 cluster opposite to samples from the same site), greater connectivity in this region seems more likely.

24

25 In contrast, the isolated island populations in the East Kimberley indicated high levels of genetic
26 differentiation. Evidence of gene flow within the East Kimberley was limited by the sampling regime,
27 however, the F_{ST} values between the two geographically close East Kimberley populations (0.166) were
28 comparable to those found between the East and West Kimberley (0.184-0.274), indicating longer term
29 isolation of these sites (longer than from 1972 when the Ord River Irrigation Scheme developed Lake

1 Argyle as a major storage reservoir and turned these sites into isolated islands). Long term isolation was
2 also evident from mtDNA data, not only with significant Φ_{ST} values between islands, but distinct MI and
3 BI lineages with up to 5.9% SD. This SD is similar to levels of divergences found between subspecies
4 and ESUs in other rock-wallabies (e.g., 5.3% *P. xanthopus*, Pope *et al.* 1996; 5% *P. lateralis*, Eldridge *et*
5 *al.* 2001; 7.6% *P. penicillata*, Browning *et al.* 2001), but over much greater distances (400-1000 km)
6 apart. These results are consistent with the findings of a broader phylogeographic study (Potter *et al.*
7 2012a) which found that MI and BI belonged to distinct lineages that have been separated by the Ord
8 River (= Ord Arid Intrusion; Eldridge *et al.* 2012) since the Pleistocene (~ 0.13 MYA).

9

10 The microsatellite diversity was also variable between the continuous and fragmented habitat, with
11 fragmented populations of *P. brachyotis* having significantly lower microsatellite diversity (*AD*, *AR* and
12 *HE*) compared to those from the continuous populations (Table 2). West Kimberley *P. brachyotis* also
13 generally have higher diversity than in other rock-wallaby species (e.g., *P. penicillata*, *P. lateralis*, *P.*
14 *xanthopus*; see Table 4) which potentially reflect a larger population size and greater gene flow associated
15 with this more continuously connected habitat. Eldridge *et al.* (2010) reported high levels of microsatellite
16 diversity associated with macropodoid populations from relatively abundant or widespread species, whilst
17 low levels were typically associated with populations showing a restricted distribution including those
18 found on islands. Low levels of diversity are expected due to a loss of variation as a result of finite
19 population size and inherent problems associated with small populations (e.g., inbreeding, genetic drift;
20 Frankham 1997; Frankham *et al.* 2004, 2010). Low genetic diversity associated with a restricted
21 distribution could explain the reduced diversity of *P. brachyotis* from the East Kimberley, located on
22 small (50-100 ha) islands within Lake Argyle. This pattern of reduced genetic diversity is supported by
23 other populations of rock-wallabies on islands (e.g., *P. lateralis*; Eldridge *et al.* 1999).

24

25 *Effects of life-history strategies*

26

27 As well as habitat impacts on population biology, life-history strategies appear to be in place within *P.*
28 *brachyotis* to preserve genetic integrity, with no evidence for inbreeding in MI and BI despite low genetic
29 diversity and high levels of relatedness for both males and females (Queller and Goodnight 1989; mean

1 estimator) within these populations ($r = 0.251-0.797$ MI; $r = 0.118-0.693$ BI). The presence of
2 significantly related individuals is common within rock-wallaby populations and has been associated with
3 strong female philopatry and spatial patterns associated with their habitat specificity (Hazlitt et al. 2004,
4 2006b; Piggott et al. 2006a). Aside from high relatedness, the results from *P. brachyotis* support other
5 rock-wallaby studies which highlight inbreeding avoidance mechanisms despite limited gene flow
6 between populations (e.g. male-biased dispersal; Hazlitt et al. 2004, 2006b). Amongst the six populations
7 sampled in this study, four first generation migrants were detected all of which were male (supported by
8 both GENECLASS and STRUCTURE results). Although the possibility of female dispersal cannot be
9 discounted (Eldridge et al. 2001 has shown it occurs), the strong female philopatry indicated by the
10 mtDNA results and low differentiation for microsatellite markers suggests these rock-wallabies most
11 likely display sex-biased dispersal. Limited female-mediated gene flow is consistent with other rock-
12 wallabies (Hazlitt et al. 2004, 2010; Piggott et al. 2006a) and supports suggestions that dispersal for
13 macropodoids is generally male-biased (Eldridge et al. 2010). The isolation by distance results also
14 indicate greater female genetic similarity to geographic distance compared to males, in both the overall
15 and the West Kimberley analyses ($r = 0.73$ vs. 0.68 ; $r = 0.36$ vs. 0.25 , respectively). Significant yet lower
16 correlation values of isolation by distance in the West Kimberley may reflect a limit to dispersal distance
17 between populations and highlight the influence continuous habitat may play in potential stepping stone
18 methods of dispersal across the landscape. Mating system preferences such as kin avoidance and sex-
19 biased dispersal have been suggested to facilitate inbreeding avoidance (Hazlitt et al. 2006b) and help
20 maintain genetic diversity within *Petrogale* populations (Spencer et al. 1997). As the two island
21 populations have only recently been isolated, it may not yet be evident if mating system strategies are in
22 place or if the effects of genetic drift and inbreeding are just not detected.

23

24 *Conclusions and future implications*

25

26 Despite the Kimberley having relatively few threats in the past, human impacts associated with increased
27 fire frequency and intensity, introduction of invasive species (e.g., cane toads), mining, grazing and
28 predation by feral animals, threaten to cause faunal declines and extinctions (Braithwaite and Muller
29 1997; Eliot et al. 1999; Fitzsimons et al. 2010; McKenzie and Burbidge 2002; Woinarski 1992;

1 Woinarski et al. 2001). Our results indicate that West and East Kimberley populations of *P. brachyotis*
2 are genetically distinct and could reflect a common pattern for other sandstone endemics (Potter et al.
3 2012a). This has implications for future management plans if threats described above do cause species to
4 become endangered.

5
6 This study suggests that habitat connectivity plays a critical role in enabling dispersal within *P.*
7 *brachyotis*, which exhibits high philopatry and strong habitat specificity. Despite evidence of male-biased
8 dispersal and female philopatry, these results suggest that species' biology does not necessarily lead to
9 genetic differentiation of rock-wallabies, with low genetic differentiation observed across suitable habitat.
10 The results indicate that fragmentation alone may not influence the genetic differentiation of *P.*
11 *brachyotis*, however, evidence suggests that connectivity between populations can reduce the effects of
12 life-history traits within *P. brachyotis* and maintain higher genetic diversity/integrity. Our results suggest
13 that patterns of genetic differentiation found in fragmented populations of rock-wallabies may not
14 represent natural population structure but be a consequence of post-decline isolation and reduced gene
15 flow, and therefore should be managed accordingly.

18 **Acknowledgements**

19
20 We would like to thank the following for providing samples or assisting with sample collection: Cecilia
21 Myers, Henry Cook, Alexander Dudley, George Madani, Raz Martin, Liberty Olds, Jim Reside, Michael
22 Elliott, Kathy Saint, Melanie Lancaster, Emily Miller, David Pearson, Lauren Brown, Bill Stewart,
23 Mitchell River and Miriuwung Gajerrong rangers and Department of Environment and Conservation staff
24 for providing samples, assisting with sample collection, mapping or laboratory protocols. We are also
25 grateful to Craig Moritz and Mike Westerman for helpful comments on a thesis version of the manuscript.

26
27 This research was supported by funding from The Dunkeld Pastoral Company Pty. Ltd., ANZ Holsworth
28 Wildlife Research Fund, The Australian Museum, The University of Adelaide, Conservation Ark (The
29 Royal Zoological Society of South Australia) and South Australian Museum.

1
2
3
4
5
6
7
8
9
10
11
12
13
14
15
16
17
18
19
20
21
22
23
24
25
26
27

References

Amos W, Balmford A (2001) When does conservation genetics matter? *Hered.* 87:257-265

Banks SC, Ward SJ, Lindenmayer B, Finlayson GR, Lawson SJ, Taylor AC (2005) The effects of habitat fragmentation on the social kin structure and mating system of the agile antechinus, *Antechinus agilis*. *Mol. Ecol.* 14: 1789-1801

Bee CA, Close RL (1993). Mitochondrial DNA analysis of introgression between adjacent taxa of rock wallabies, *Petrogale* species (Marsupialia: Macropodidae). *Genet. Res.* 61: 21-37

Braithwaite RW, Muller WJ (1997) Rainfall, groundwater and refuges: predicting extinctions of Australian tropical mammal species. *Aust. J. Ecol.* 22:57-67

Broquet T, Petit E (2004). Quantifying genotyping errors in noninvasive population genetics. *Mol. Ecol.* 13: 3601-3608

Brouat C, Sennedot F, Audiot P, Leblois R, Rasplus J-Y (2003) Fine-scale genetic structure of two carabid species with contrasted levels of habitat specialization. *Mol. Ecol.* 12:1731-1745

Browning TL, Taggart DA, Rummery C, Close RL, Eldridge MDB (2001) Multifaceted genetic analysis of the "Critically Endangered" brush-tailed rock-wallaby *Petrogale penicillata* in Victoria, Australia: implications for management. *Conserv. Genet.* 2:145-156

Cabe PR, Page RB, Hanlon TJ, Aldrich ME, Connors L, Marsh DM (2007) Fine-scale population differentiation and gene flow in a terrestrial salamander (*Plethodon cinereus*) living in continuous habitat. *Hered.* 98:53-60

Cornuet J-M, Piry S, Luikart G, Estoup A, Solignac M (1999) New methods employing multilocus genotypes to select or exclude populations as origins of individuals. *Genetics* 153:1989-2000

Department of Environment and Climate Change (2008) Recovery plan for the brush-tailed rock-wallaby (*Petrogale penicillata*). Sydney South

Department of Environment and Heritage (2006) Bounceback Progress Report. Adelaide

1 Department of Environment and Resource Management (2010) National recovery plan for the Proserpine
2 rock-wallaby *Petrogale persephone*. Report to Department of Sustainability, Environment, Water,
3 Population and Communities, Canberra. Brisbane

4 Eldridge MDB, King JM, Loupis AK, Spencer PBS, Taylor AC, Pope LC, Hall GP (1999)
5 Unprecedented low levels of genetic variation and inbreeding depression in an island population of the
6 black-footed rock-wallaby. *Conserv. Biol.* 13 (3):531-541

7 Eldridge MDB, Kinnear JE, Onus ML (2001) Source population of dispersing rock-wallabies (*Petrogale*
8 *lateralis*) identified by assignment tests on multilocus genotypic data. *Mol. Ecol.* 10:2867-2876

9 Eldridge MDB, Kinnear JE, Zenger KR, McKenzie LM, Spencer PBS (2004a) Genetic diversity in
10 remnant mainland and "pristine" island populations of three endemic Australian macropodids
11 (Marsupialia): *Macropus eugenii*, *Lagorchestes hirsutus* and *Petrogale lateralis*. *Conserv. Genet.*
12 5:325-338

13 Eldridge MDB, Rummery C, Bray C, Zenger KR, Browning TL, Close RL (2004b) Genetic analysis of a
14 population crash in brush-tailed rock-wallabies (*Petrogale penicillata*) from Jenolan Caves, south-
15 eastern Australia. *Wildlife Res.* 31:229-240

16 Eldridge MDB (2008) Rock-wallabies: *Petrogale*. In: Van Dyck S, Strahan R (eds) *The Mammals of*
17 *Australia*, third edition. New Holland, Sydney, pp 361-362

18 Eldridge MDB, Piggott MP, Hazlitt SL (2010) Population genetic studies of the Macropodoidea: a
19 review. In: Coulson G, Eldridge M (eds) *Macropods: the biology of kangaroos, wallabies and rat-*
20 *kangaroos*. CSIRO Publishing, Collingswood VIC, pp 35-52

21 Eldridge MDB, Potter S, Cooper SJB (2012 in press) Biogeographic barriers in north-western Australia:
22 an overview and standardisation of nomenclature.

23 Eliot I, Finlayson CM, Waterman P (1999) Predicted climate change, sea-level rise and wetland
24 management in the Australian wet-dry tropics. *Wetl. Ecol. Manag.* 7:63-81

25 Evanno G, Regnaut S, Goudet J (2005) Detecting the number of clusters of individuals using the software
26 STRUCTURE: a simulation study. *Mol. Ecol.* 14:2611-2620

27 Ewers RM, Didham RK (2006) Confounding factors in the detection of species responses to habitat
28 fragmentation. *Biol. Rev.* 81:117-142

1 Excoffier L, Laval G, Schneider S (2005) Arlequin ver. 3.0: an integrated software package for
2 population genetics data analysis. *Evol. Bioinform. Online* 1:47-50

3 Fahrig L (2003) Effects of habitat fragmentation on biodiversity. *Annu. Rev. Ecol. Evol. Syst.* 34:487-
4 515

5 Fischer JF, Lindenmayer DB, Barry S, Flowers E (2005) Lizard distribution patterns in the Tumut
6 fragmentation "natural experiment" in south-eastern Australia. *Biol. Conserv.* 123 (3):301-315

7 Fitzsimons J, Legge S, Traill B, Woinarski J (2010) Into oblivion? The disappearing native mammals of
8 northern Australia. Melbourne

9 Frankham R (1997) Do island populations have less genetic variation than mainland populations? *Hered.*
10 78:311-327

11 Frankham R, Ballou JD, Briscoe DA, McInnes KH (2004) A primer of conservation genetics. Cambridge
12 University Press, Cambridge, UK

13 Frankham R, Ballou JD, Briscoe DA (2010) Introduction to conservation genetics second edition.
14 Cambridge University Press, Cambridge, UK

15 Fumagalli L, Pope LC, Taberlet P, Moritz C (1997) Versatile primers for the amplification of the
16 mitochondrial DNA control region in marsupials. *Mol. Ecol.* 6:1199-1201

17 Gilpin M, Hanski I (1991) Metapopulation dynamics: empirical and theoretical investigations. Academic
18 Press, San Diego, California

19 Goudet J (1995) FSTAT (Version 1.2): A computer program to calculate F-statistics. *J. Hered.* 86:485-
20 486

21 Harris LD (1984) The fragmented forest: island biogeography theory and preservation of biotic diversity.
22 University of Chicago Press, Chicago

23 Hazlitt SL, Eldridge MDB, Goldizen AW (2004) Fine-scale spatial genetic correlation analyses reveal
24 strong female philopatry within a brush-tailed rock-wallaby colony in southeast Queensland. *Mol. Ecol.*
25 13:3621-3632

26 Hazlitt SL, Eldridge MDB, Goldizen AW (2010) Strong matrilineal structuring in the brush-tailed rock-
27 wallaby confirmed by spatial patterns of mitochondrial DNA. In: Coulson G, Eldridge M (eds)
28 Macropods: the biology of kangaroos, wallabies and rat-kangaroos. CSIRO publishing, Collingswood
29 VIC, pp 87-95

1 Hazlitt SL, Goldizen AW, Eldridge MDB (2006a) Significant patterns of population genetic structure and
2 limited gene flow in a threatened macropodid marsupial despite continuous habitat in southeast
3 Queensland, Australia. *Conserv. Genet.* 7 (5):675-689

4 Hazlitt SL, Sigg DP, Eldridge MDB, Goldizen AW (2006b) Restricted mating dispersal and strong
5 breeding group structure in a mid-sized marsupial mammal (*Petrogale penicillata*). *Mol. Ecol.* 15:2997-
6 3007

7 Hedrick PW (2000) *Genetics of populations*. Jones and Bartlett Publishers, Sudbury, MA

8 Henle K, Davies KF, Kleyer M, Margules C, Settele J (2004) Predictors of species sensitivity to
9 fragmentation. *Biodivers. Conserv.* 13:207-251

10 Huelsenbeck JP, Ronquist F (2005) Bayesian analysis of molecular evolution using MrBayes. In: Nielsen
11 R (ed) *Statistical Methods in Molecular Evolution*. Springer, New York, pp 183-232

12 Jarman PJ, Bayne P (1997) Behavioural ecology of *Petrogale penicillata* in relation to conservation.
13 *Aust. Mammal.* 19:219-228

14 Jones Lennon M, Taggart DA, Temple-Smith PD, Eldridge MDB (2011) The impact of isolation and
15 bottlenecks on genetic diversity in the Pearson Island population of the black-footed rock-wallaby
16 (*Petrogale lateralis pearsoni*; Marsupialia: Macropodidae). *Aust. Mammal.* 33:152-161

17 Kimura M (1981) Estimation of evolutionary distances between homologous nucleotide sequences. *P.*
18 *Natl. Acad. Sci. USA* 78 (1):454-458

19 Kraaijeveld-Smit FJL, Lindenmayer DB, Taylor AC, MacGregor C, Wertheim B (2007) Comparative
20 genetic structure reflects underlying life histories of three sympatric small mammal species in
21 continuous forest of south-eastern Australia. *Oikos* 116:1819-1830

22 Lacy RC (1987) Loss of genetic diversity from managed populations: interacting effects of drift,
23 mutation, immigration, selection, and population subdivision. *Conserv. Biol.* 1:143-158

24 Lancaster ML, Taylor AC, Cooper SJB, Carthew SM (2011) Limited ecological connectivity of an
25 arboreal marsupial across a forest/plantation landscape despite apparent resilience to fragmentation.
26 *Mol. Ecol.* 20:2258-2271

27 Langella O (1999) Populations 1.2.32. Accessed at: <http://bioinformatics.org/>

28 Librado P, Rozas J (2009) DnaSP v5: a software for comprehensive analysis of DNA polymorphism data.
29 *Bioinformatics* 25:1451-1452

- 1 Lindenmayer DB, Fischer JF (2006) Landscape change and habitat fragmentation: an ecological and
2 conservation synthesis. Island Press, Washington, DC
- 3 Macqueen PE, Nicholls JA, Hazlitt SL, Goldizen AW (2008) Gene flow among native bush rat, *Rattus*
4 *fuscipes* (Rodentia: Muridae), populations in the fragmented subtropical forests of south-east
5 Queensland. *Austral Ecol.* 33:585-593
- 6 Mantel N (1967) The detection of disease clustering and a generalized regression approach. *Cancer Res.*
7 27:209-220
- 8 Maxwell S, Burbidge AA, Morris K (1996) The 1996 action plan for Australian marsupials and
9 monotremes. Canberra
- 10 McKenzie NL, Burbidge AA (2002) Australian mammal audit. Canberra
- 11 Meyer CFJ, Kalko EKV, Kerth G (2009) Small-scale fragmentation effects on local genetic diversity in
12 two Phyllostomid bats with different dispersal abilities in Panama. *Biotropica* 41:95-102
- 13 Miller MP (2005) Alleles in space: computer software for the joint analysis of interindividual spatial and
14 genetic information. *J.Hered.* 96:722-724
- 15 Miller EJ, Eldridge MDB, Cooper DW, Herbert CA (2010). Dominance, body size and internal
16 relatedness influence male reproductive success in eastern grey kangaroos (*Macropus giganteus*).
17 *Reprod. Fert. Develop.* 22: 539-549
- 18 Nei M (1972) Genetic distance between populations. *Amer. Nat.* 106: 283-291
- 19 Nei M, Tajima F, Tateno Y (1983) Accuracy of estimated phylogenetic trees from molecular data. II.
20 Gene frequency data. *J. Mol. Evol.* 19:153-170
- 21 O'Neill RJW, Eldridge MDB, Crozier RH, Marshall Graves JA (1997) Low levels of sequence divergence
22 in rock wallabies (*Petrogale*) suggest a lack of positive directional selection in *Sry*. *Mol. Biol. Evol.* 14
23 (3):350-353
- 24 Öckinger E, Schweiger O, Crist TO, Debinski DM, Krauss J, Kuussaari M, Petersen JD, Pöyry J, Settele
25 J, Summerville KS, Bommarco R (2010) Life-history traits predict species responses to habitat area and
26 isolation: a cross-continental synthesis. *Ecol. Lett.* 13:969-979
- 27 Osborne MJ, Christidis L (2001) Molecular phylogenetics of Australo-Papuan possums and gliders
28 (family Petauridae). *Mol. Phylogenet. Evol.* 20:211-224

- 1 Paetkau D, Slade R, Burden M, Estoup A (2004) Genetic assignment methods for the direct, real-time
2 estimation of migration rate: a simulation-based exploration of accuracy and power. *Mol. Ecol.* 13:55-
3 65
- 4 Paplinska JZ (2006) Faecal DNA analysis of *Petrogale penicillata* in Kangaroo Valley. Final report for
5 NSW Parks and Wildlife Service. New South Wales National Parks and Wildlife Service. Sydney
- 6 Peacock MM, Smith AT (1997) The effect of habitat fragmentation on dispersal patterns, mating
7 behavior, and genetic variation in a pika (*Ochotona princeps*) metapopulation. *Oecologia* 112:524-533
- 8 Peakall R, Smouse PE (2006) GENALEX 6: genetic analysis in Excel. Population genetic software for
9 teaching and research. *Mol. Ecol. Notes* 6:288-295
- 10 Piggott MP, Banks SC, Taylor AC (2006a) Population structure of brush-tailed rock-wallaby (*Petrogale*
11 *penicillata*) colonies inferred from analysis of faecal DNA. *Mol. Ecol.* 15:93-105
- 12 Piggott MP, Banks SC, Stone N, Banffy C, Taylor AC (2006b) Estimating population size of endangered
13 brush-tailed rock-wallaby (*Petrogale penicillata*) colonies using faecal DNA. *Mol. Ecol.* 15:81-91
- 14 Piggott MP, Taylor AC (2003) Extensive evaluation of faecal preservation and DNA extraction methods
15 in Australian native and introduced species. *Aust. J. Zool.* 51:341-355
- 16 Piry S, Alapetite A, Cornuet JM, Paetkau D, Baudouin L, Estoup A (2004) GeneClass2: a software for
17 genetic assignment and first-generation migrant detection. *J. Hered.* 95:536-539
- 18 Pope LC, Sharp A, Moritz C (1996) Population structure of the yellow-footed rock-wallaby *Petrogale*
19 *xanthopus* (Gray, 1854) inferred from mtDNA sequences and microsatellite loci. *Mol. Ecol.* 5:629-640
- 20 Posada D, Crandall KA (1998) Modeltest: testing the model of DNA substitution. *Bioinformatics* 14:
21 817-818
- 22 Potter S, Eldridge MDB, Taggart DA, Cooper SJB (2012a) Multiple biogeographic barriers identified
23 across the monsoon tropics of northern Australia: phylogeographic analysis of the *brachyotis* group of
24 rock-wallabies. *Mol. Ecol.* In press
- 25 Potter S, Cooper SJB, Metcalfe CJ, Taggart DA, Eldridge MDB (2012b) Phylogenetic relationships of
26 rock-wallabies, *Petrogale* (Marsupialia: Macropodidae) and their biogeographic history within
27 Australia. *Mol. Phylogenet. Evol.* 62:640-652
- 28 Pritchard JK, Stephens M, Donnelly P (2000) Inference of population structure using multilocus genotype
29 data. *Genetics* 155:945-959

1 Prugh LR, Hodges KE, Sinclair ARE, Brashares JS (2008) Effect of habitat area and isolation on
2 fragmented animal populations. P. Natl. Acad. Sci. USA 105:20770-20775

3 Queller DC, Goodnight KF (1989) Estimating relatedness using genetic markers. Evolution 43 (2):258-
4 275

5 Rambaut A (1996) Se-Al: Sequence Alignment Editor.

6 Rannala B, Mountain JL (1997) Detecting immigration by using multilocus genotypes. P. Natl. Acad. Sci.
7 USA 94:9197-9201

8 Raymond M, Rousset F (1995) GENEPOP (Version 1.2): population genetics software for exact tests and
9 ecumenicism. J. Hered. 86:248-249

10 Read JL, Ward MJ (2010) Warru Recovery Plan: recovery of *Petrogale lateralis* MacDonnell Ranges
11 race in South Australia, 2010-2020. Adelaide

12 Rice WR (1989) Analyzing tables of statistical tests. Evolution 43:223-225

13 Ronquist F, Huelsenbeck JP (2003) MrBayes3: Bayesian phylogenetic inference under mixed models.
14 Bioinformatics 19 (12):1572-1574

15 Rozas J, Sanchez-DelBarrio JC, Messeguer X, Rozas R (2003) DnaSP, DNA polymorphism analyses by
16 the coalescent and other methods. Bioinformatics 19:2496-2497

17 Ruibal M, Peakall R, Claridge A, Firestone K (2009). Field-based evaluation of scat DNA methods to
18 estimate population abundance of the spotted-tailed quoll (*Dasyurus maculatus*), a rare Australian
19 marsupial. Wildlife Res. 36:721-736

20 Slatkin M (1994) Gene flow and population structure. In: Real LA (ed) Ecological genetics. Princeton
21 University Press, Princeton, New Jersey., pp 3-17

22 Smith JNM, Hellmann JJ (2002) Population persistence in fragmented landscapes. Trends Ecol. Evol.
23 17:397-399

24 Spencer PBS, Marsh H (1997) Microsatellite DNA fingerprinting confirms dizygotic twinning and
25 paternity in the Allied Rock-wallaby, *Petrogale assimilis* (Marsupialia: Macropodidae). Aust. Mammal.
26 19:279-280

27 Spencer PBS, Adams M, Marsh H, Miller DJ, Eldridge MDB (1997) High levels of genetic variability in
28 an isolated colony of rock-wallabies (*Petrogale assimilis*): evidence from three classes of molecular
29 markers. Aust. J. Zool. 45:199-210

1 Spencer PBS, Odorico DM, Jones SJ, Marsh HD, Miller DJ (1995) Highly variable microsatellites in
2 isolated colonies of the rock-wallaby (*Petrogale assimilis*). Mol. Ecol. 4:523-525

3 Stamatakis A (2006) RAxML-VI-HPC: maximum likelihood-based phylogenetic analyses with thousands
4 of taxa and mixed models. Bioinformatics 22 (21):2688-2690

5 Stamatakis A, Hoover P, Rougemont J (2008) A rapid bootstrap algorithm for the RAxML web-servers.
6 Syst. Biol. 57:758-771

7 Stow AJ, Sunnucks P (2004) Inbreeding avoidance in Cunningham's skinks (*Egernia cunninghami*) in
8 natural and fragmented habitat. Mol. Ecol. 13:443-447

9 Stow AJ, Sunnucks P, Briscoe DA, Gardner MG (2001) The impact of habitat fragmentation on dispersal
10 of Cunningham's skink (*Egernia cunninghami*): evidence from allelic and genotypic analyses of
11 microsatellites. Mol. Ecol. 10:867-878

12 Swofford D (2002) PAUP*. 4.0b10 edn. Sinauer Associates, Inc. Publishers, Sunderland, Massachusetts

13 Taylor AC, Cooper DW (1998) A set of tammar wallaby (*Macropus eugenii*) microsatellites tested for
14 genetic linkage. Mol. Ecol. 7:925-926

15 Telfer WR, Eldridge MDB (2010) High levels of mitochondrial DNA divergence within short-eared rock-
16 wallaby (*Petrogale brachyotis*) populations in northern Australia. Aust. J. Zool. 58 (2):104-112

17 Thompson JD, Gibson TJ, Plewniak F, Jeanmougin F, Higgins DG (1997) The ClustalX windows
18 interface: flexible strategies for multiple sequence alignment aided by quality analysis tools. Nucleic
19 Acids Res. 25:4876-4882

20 Valière N (2002) GIMLET: a computer program for analysing genetic individual identification data. Mol.
21 Ecol. 2: 377-379

22 Van Dyck S, Strahan R (2008) The Mammals of Australia, third edition. New Holland, Sydney

23 Van Oosterhout C, Hutchinson WF, Wills DPM, Shipley P (2004) Micro-checker: software for
24 identifying and correcting genotyping errors in microsatellite data. Mol.Ecol. Notes 4: 535-538

25 Walker FM, Sunnucks P, Taylor AC (2008) Evidence for habitat fragmentation altering within-population
26 processes in wombats. Mol. Ecol. 17:1674-1684

27 Weir BS, Cockerham CC (1984) Estimating F-statistics for the analysis of population structure. Evolution
28 38:1358-1370

1 Woinarski JCZ (1992) Biogeography and conservation of reptiles, mammals and birds across north-
2 western Australia: an inventory and base for planning an ecological reserve system. *Wildlife Res.*
3 19:665-705

4 Woinarski JCZ, Milne DJ, Wanganeen G (2001) Changes in mammal populations in relatively intact
5 landscapes of Kakadu National Park, Northern Territory, Australia. *Austral Ecol.* 26:360-370

6 Wright, S (1951) The genetical structure of populations. *Ann. Eugen.* 15: 323-354

7 Wolff JO, Schauber EM, Edge WD (1997) Effects of habitat loss and fragmentation on the behavior and
8 demography of gray-tailed voles. *Conserv. Biol.* 11:945-956

9 Zenger KR, Cooper DW (2001) A set of highly polymorphic microsatellite markers developed for the
10 eastern grey kangaroo (*Macropus giganteus*). *Mol. Ecol.* 1:98-100

11 Zenger KR, Eldridge MDB, Pope LC, Cooper DW (2003) Characterisation and cross-species utility of
12 microsatellite markers within kangaroos, wallabies and rat kangaroos (Macropodoidea: Marsupialia).
13 *Aust. J. Zool.* 51:587-596

14 **Table 1**

Population	Sample ID	Latitude/Longitude	Sample Size	Haplotype	mtDNA lineage
Couchman (CN)	ABTC99376, ABTC99377, ABTC99379, ABTC99380, ABTC99381, ABTC99382, ABTC99383, ABTC99384, ABTC99385, ABTC99386, ABTC99387, ABTC99388, ABTC99389, ABTC99390, ABTC99391, ABTC99392, ABTC99393, ABTC99394, ABTC99395, ABTC103715, CN01, CN02, CN03, CN04, CN05, CN06, CN07, CN08, CN09	204755 8321547	29	A (17) B (1) C (2)	WK WK WK
Cypress Valley (CV)	ABTC99396, ABTC100692, ABTC100693, ABTC100694, ABTC100695, ABTC100696, ABTC100697, ABTC100698, ABTC100699, ABTC100700, ABTC103330, ABTC103331, ABTC103332	231724 8361617	13	D (1) E (1) F(9) G(2)	WK WK WK WK
Monsmont Island (MI)	ABTC103495, ABTC103496, ABTC103497, ABTC103498, ABTC103499, ABTC101500, ABTC103501, ABTC103502, ABTC103503, ABTC103504, ABTC103505	467949 8198163	11	H (1) I (9) J (1)	EK1 EK1 EK1
Bullanyin Island (BI)	ABTC103506, ABTC103507, ABTC103508, ABTC103509, ABTC103510, ABTC103511, ABTC103512	464389 8198066	7	K (1) L (5) M (1)	EK2 EK2 EK2
King Edward River	KER01, KER02, KER03, KER04,	194873 8305693	11		

(KER)	KER05, KER06, KER07, KER08, KER09, KER10, KER11		
Pump Hill (PH)	PH01, PH02, PH03, PH04, PH05, PH06, PH07, PH08, PH09, PH10, PH11, PH12, PH13	232154 8360873	13

- 1 No mtDNA sequence data was obtained from the KER and PH scat samples. *MtDNA lineages (WK =
- 2 West Kimberley; EK1 = East Kimberley ; EK2 = East Kimberley 2) follow Potter et al. (2012a).

Table 2

Sample Location	h (\pm SD)	π	AD (\pm SD)	AR (\pm SD)	H_E (\pm SD)	A_U	FIS
Couchman	0.279 \pm 0.123	0.00063	8.3 (\pm 3.1)	5.3 (\pm 1.5)	0.745 (\pm 0.16)	9	-0.003
Cyprus Valley	0.526 \pm 0.153	0.00775	6.9 (\pm 2.4)	5.6 (\pm 1.7)	0.755 (\pm 0.20)	7	0.041
Monsmont Is.	0.182 \pm 0.144	0.00032	4.1 (\pm 1.5)	3.6 (\pm 1.3)	0.573 (\pm 0.19)	6	-0.035
Bullanyin Is.	0.286 \pm 0.196	0.00025	4.4 (\pm 1.5)	4.4 (\pm 1.5)	0.661 (\pm 0.17)	10	0.030
King Edward River			6.3 (\pm 2.8)	5.2 (\pm 2.1)	0.763 (\pm 0.15)	2	-0.096
Pump Hill			6.8 (\pm 2.1)	5.4 (\pm 1.5)	0.771 (\pm 0.15)	2	0.042

Table 3

	CN	CV	MI	BI	KER
CN		0.856*	0.993*	0.993*	
CV	0.043*		0.935*	0.929*	
MI	0.256*	0.274*		0.995*	
BI	0.202*	0.209*	0.166*		
KER	0.027*	0.058*	0.248*	0.184*	
PH	0.051*	0.022	0.265*	0.201*	0.059*

*significant ($P < 0.05$) after Bonferroni correction.

1

2 **Table 4**

Taxon	No. of individuals (and site)	No. of loci	AD	H_E	Reference
<i>Petrogale assimilis</i>	128 (Black Rock)	5	11.6	0.86	(Spencer and Marsh 1997)
	15 (Little Black Rock)	5	8.6	0.85	(Spencer et al. 1995)
<i>Petrogale brachyotis</i>	32 (East Alligator)	10	7.8	0.78	(Telfer and Eldridge 2010)
	14 (Florence Falls)	10	3.4	0.55	(Telfer and Eldridge 2010)
	30 (Buley)	10	4.6	0.62	(Telfer and Eldridge 2010)
<i>Petrogale penicillata</i>	28 (Ingles Rd) ^T	11	5.2	0.70	(Eldridge et al. 2004b)
	15 (Crocodile Rock) ^T	7	5.1	0.65	(Piggott et al. 2006a)
	17 (Rocky Creek) ^T	7	5.1	0.65	(Piggott et al. 2006a)
	20 (Bowmans Rd) ^T	11	5.1	0.69	(Eldridge et al. 2004b)
	44 (Wolgan, Main) ^T	7	4.9	0.65	(Piggott et al. 2006a)
	54 (Hurdle Creek) ^T	12	4.5	0.67	(Hazlitt et al. 2006a)
	17 (Broke) ^T	11	4.0	0.64	(Eldridge et al. 2004b)
	15 (Perseverance Dam) ^T	12	3.4	0.57	(Hazlitt et al. 2006a)
	19 (Kangaroo Valley) ^T	12	2.4	0.37	(Papilinska 2006)
	8 (Rocky Plains Creek) ^T	11	1.9	0.34	(Browning et al. 2001)
<i>Petrogale lateralis lateralis</i>	19 (Tutakin) ^T	11	4.0	0.62	(Eldridge et al. 2004a)
	31 (Sales Rock) ^T	11	3.5	0.55	(Eldridge et al. 2004a)
	15 (Exmouth) ^T	10	3.4	0.62	(Eldridge et al. 1999)
	32 (Mt Caroline East) ^T	11	3.3	0.51	(Eldridge et al. 2004a)
	19 (Mt Caroline West) ^T	11	3.1	0.49	(Eldridge et al. 2004a)
	19 (Nangeen Hill) ^T	11	2.5	0.41	(Eldridge et al. 2004a)
	28 (Barrow Island) ^T	10	1.2	0.05	(Eldridge et al. 1999)
<i>Petrogale lateralis pearsoni</i>	38 (North Pearson Island)	10	1.6	0.13	(Jones Lennon et al. 2011)
<i>Petrogale xanthopus celeris</i>	50 (Hill of Knowledge)	4	7.5	0.69	(Pope et al. 1996)
<i>Petrogale x. xanthopus</i>	69 (Flinders Ranges) ^{*T}	7	7.8	0.75	(Zenger et al. 2003)

3 *Samples pooled from multiple localities. ^TThreatened taxon (Maxwell et al. 1996).

4

5

6

7

8 **Figure Legends**

9

10 **Fig. 1** The distribution of the short-eared rock-wallaby (*Petrogale brachyotis*) across northern Australia
11 (top left), showing (below) the collection localities for the six populations sampled from the Kimberley,
12 Western Australia, Australia. Four sites (Couchman, Cyprus Valley, King Edward River and Pump Hill)
13 in the West Kimberley were sampled across continuous habitat, while two sites (Monsmont Island and
14 Bullanyin Island) in the East Kimberley represent fragmented populations. Sample sizes (n) are outlined

1 for each sampling locality. + represent the Northern Territory sites sampled by Telfer and Eldridge
2 (2010). Increasing elevation is indicated by darker shading (up to ~1000 m).

3
4 **Fig. 2** (a) Proportional membership (Q) of each short-eared rock-wallaby (*Petrogale brachyotis*)
5 individual to the two clusters identified by STRUCTURE, in (a) the East Kimberley associated with the
6 fragmented island populations; and (b) the West Kimberley. Each individual is represented by a single
7 vertical bar and sample IDs are outlined in the figure.

8
9 **Fig. 3** Unrooted NJ tree of populations of short-eared rock-wallaby (*Petrogale brachyotis*) from the East
10 (Monsmont and Bullanyin Islands) and West Kimberley (Couchman, Cyprus Valley, King Edward River,
11 Pump Hill) based on a matrix of D_s (Nei 1972) from microsatellite genotypes.

12
13 **Fig. 4** Maximum likelihood reconstruction (RAxML) of short-eared rock-wallaby (*Petrogale brachyotis*)
14 mtDNA haplotypes from West and East Kimberley. Bootstrap values are signified as percentages and
15 Bayesian posterior probabilities as decimal values. Haplotypes (A-M) are grouped into geographic
16 regions (BI – Bullanyin Island, MI – Monsmont Island, CN – Couchman, CV – Cyprus Valley; EK – East
17 Kimberley, WK – West Kimberley).

18
19 **Fig. 5** Mean pairwise relatedness for individual short-eared rock-wallabies (*Petrogale brachyotis*) from
20 six sites in the Kimberley, (a) males; (b) females. Error bars surround the mean pairwise relatedness value
21 based on bootstrap analysis; U and L are upper and lower 95% confidence bounds of the null hypothesis
22 (no difference across populations) permuted from 10 000 runs.

23

24

25 **Table Captions**

26

27 **Table 1** Location of sampled short-eared rock-wallabies (*Petrogale brachyotis*), the number of identified
28 mtDNA haplotypes and GenBank accession numbers.

29

1 **Table 2** Summary of genetic diversity indices for six sampled short-eared rock-wallaby (*Petrogale*
2 *brachyotis*) populations. h haplotype diversity, π nucleotide diversity, AD allelic diversity, AR allelic
3 richness (allelic diversity corrected for sample size; $n=7$), H_E mean expected heterozygosity, A_U unique
4 alleles, F_{IS} inbreeding levels. All F_{IS} values were not significantly different from zero.

5

6 **Table 3** Genetic differentiation amongst sampled short-eared rock-wallaby (*Petrogale brachyotis*)
7 populations (Couchman – CN; Cyprus Valley – CV; Monsmont Island – MI; Bullanyin Island – BI; King
8 Edward River – KER; and Pump Hill – PH). Pairwise Φ_{ST} (mtDNA) above (excluding KER and PH) and
9 F_{ST} (microsatellites) below the diagonal.

10

11 **Table 4** Reported allelic diversity (AD) and average heterozygosity (H_E) at polymorphic microsatellite
12 loci in 25 wild populations of *Petrogale* which were assessed using an assortment of the markers used in
13 this study. (Taken from Eldridge et al. 2010, including more recent results).

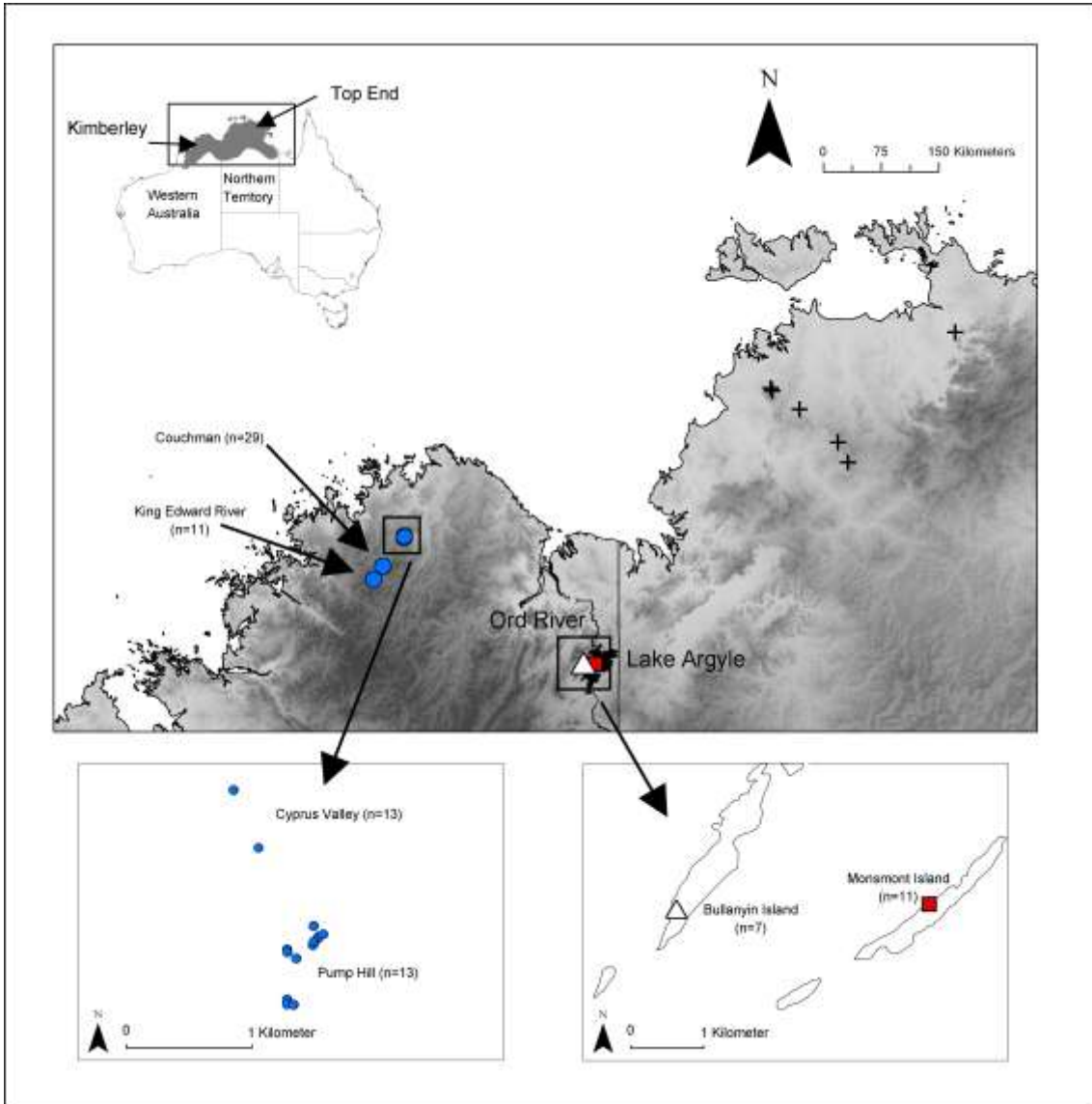

1

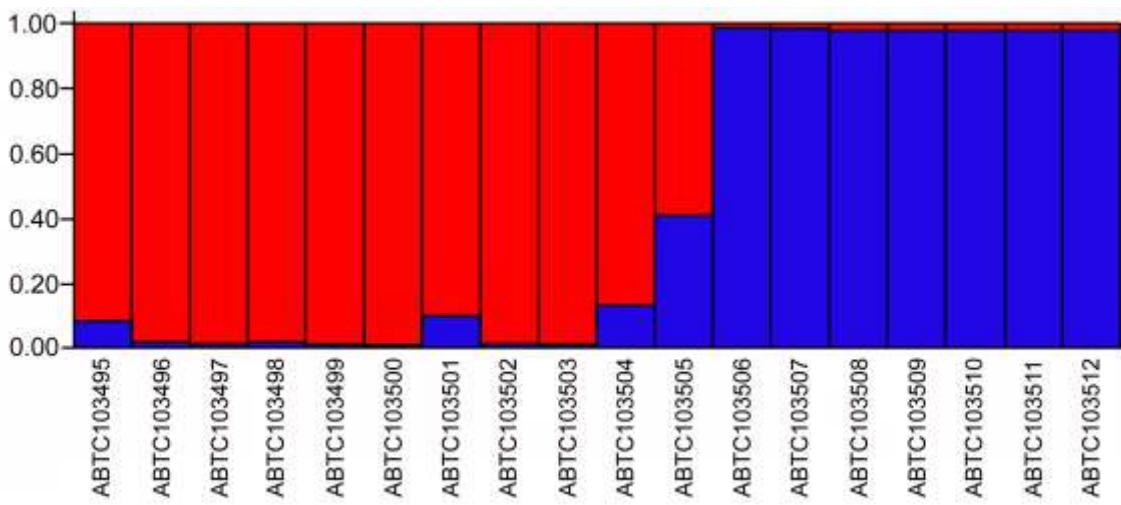

2

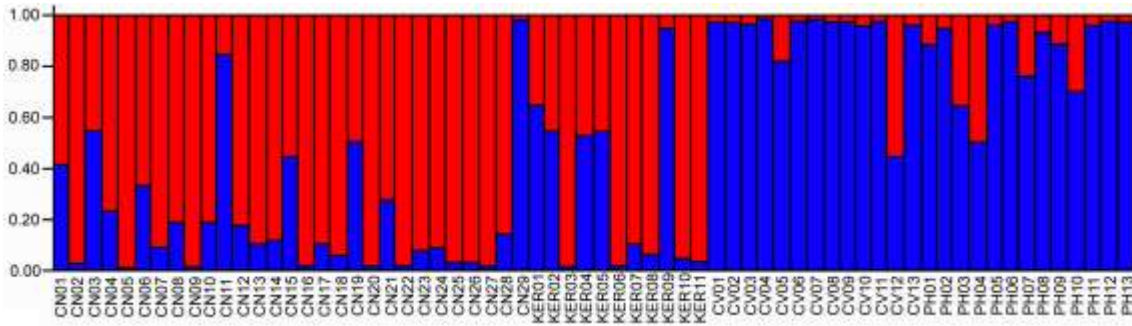

1

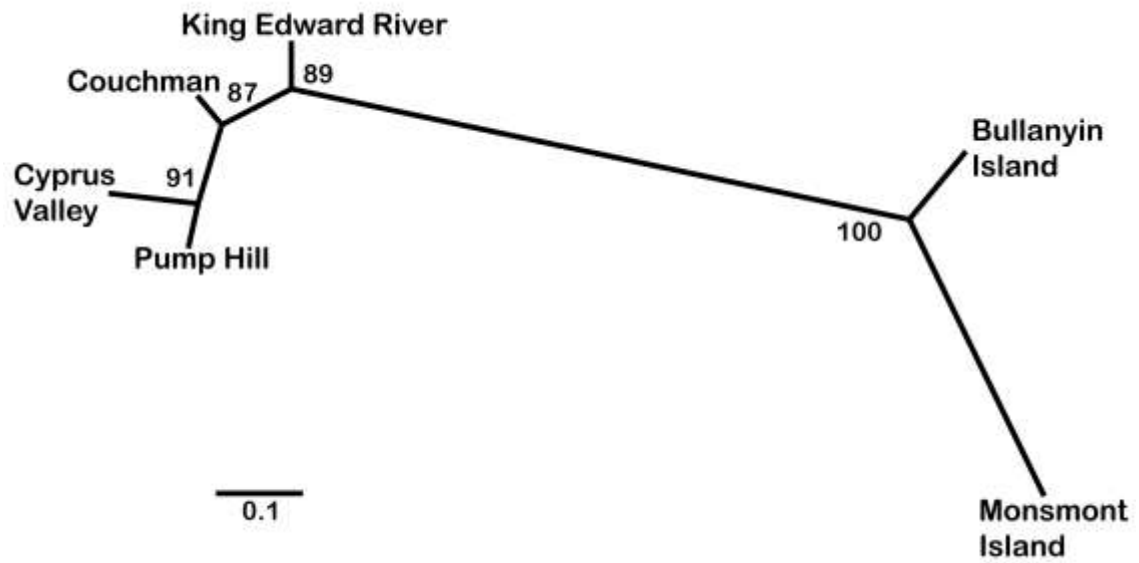

2

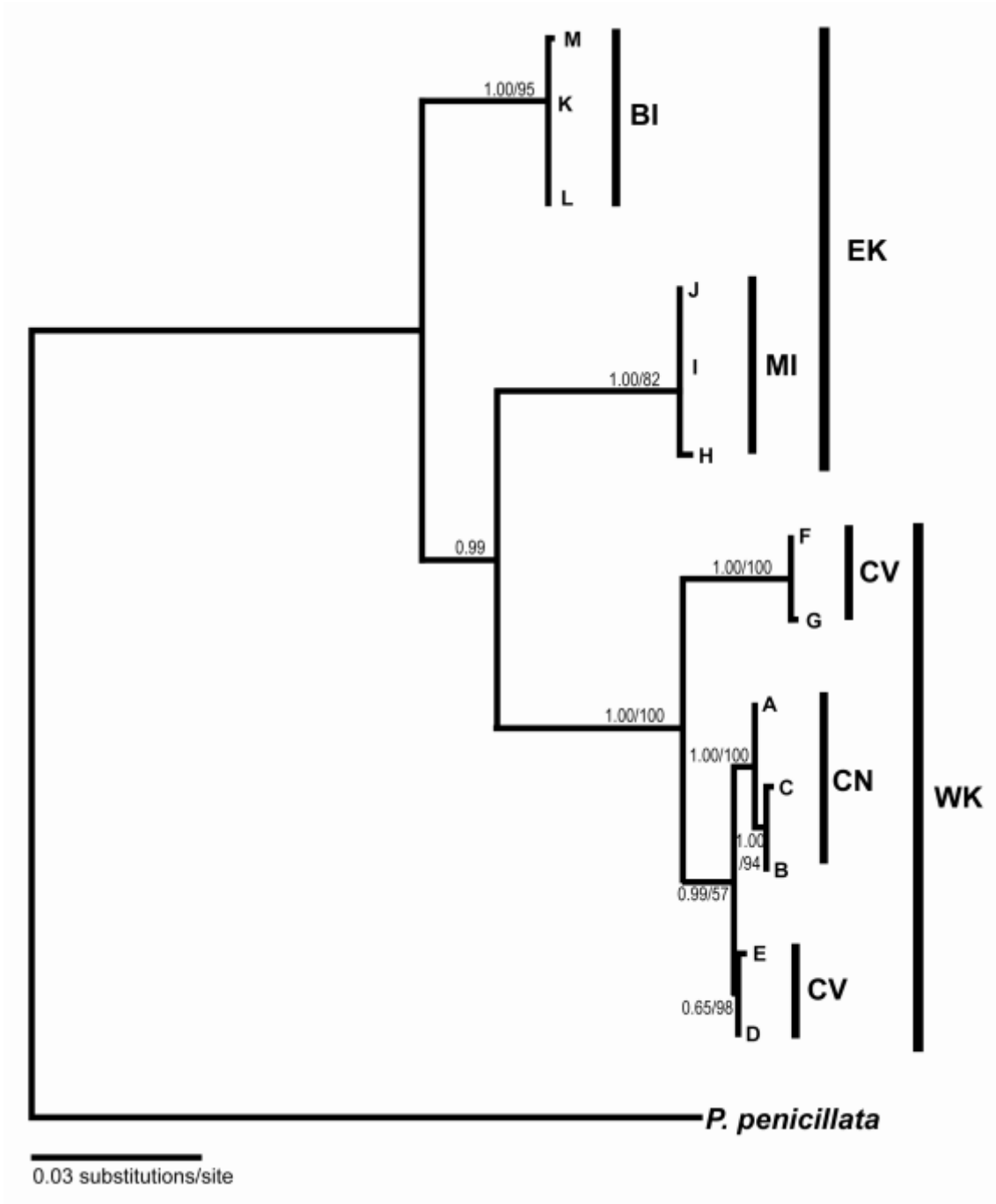

1

(a)

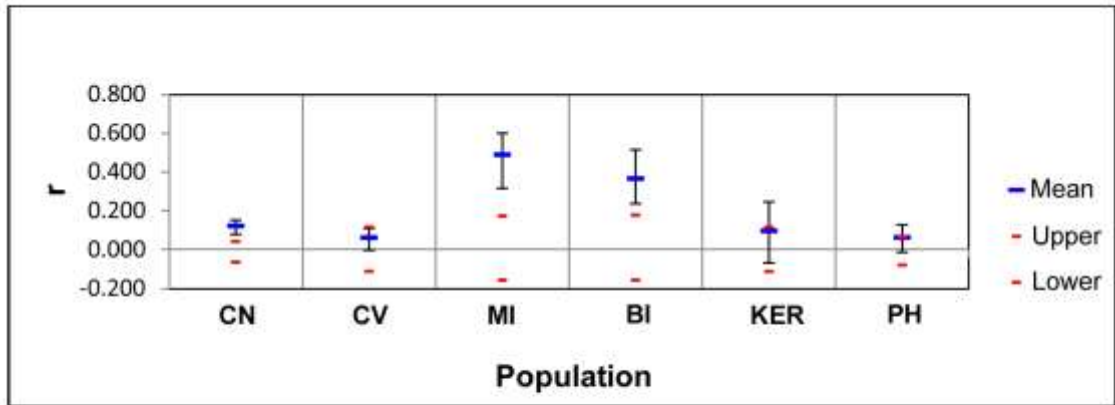

(b)

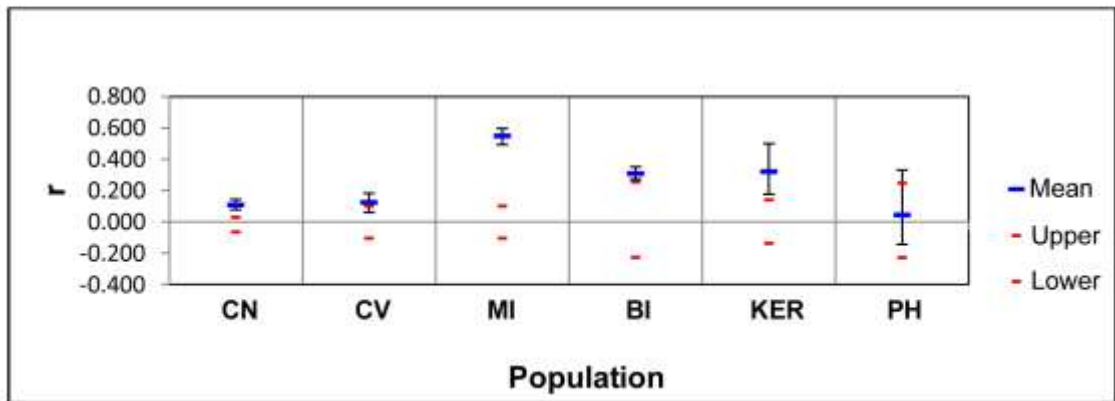

1

2



Minerva Access is the Institutional Repository of The University of Melbourne

Author/s:

Potter, S; Eldridge, MDB; Cooper, SJB; Paplinska, JZ; Taggart, DA

Title:

Habitat connectivity, more than species' biology, influences genetic differentiation in a habitat specialist, the short-eared rock-wallaby (*Petrogale brachyotis*)

Date:

2012-08-01

Citation:

Potter, S., Eldridge, M. D. B., Cooper, S. J. B., Paplinska, J. Z. & Taggart, D. A. (2012). Habitat connectivity, more than species' biology, influences genetic differentiation in a habitat specialist, the short-eared rock-wallaby (*Petrogale brachyotis*). *CONSERVATION GENETICS*, 13 (4), pp.937-952. <https://doi.org/10.1007/s10592-012-0342-1>.

Persistent Link:

<http://hdl.handle.net/11343/32951>

File Description:

Accepted version