



Minerva Access is the Institutional Repository of The University of Melbourne

Author/s:

Soltani, A;O'kelly, BC

Title:

Reappraisal of the astm/aashto standard rolling device method for plastic limit determination of fine-grained soils

Date:

2021-06-01

Citation:

Soltani, A. & O'kelly, B. C. (2021). Reappraisal of the astm/aashto standard rolling device method for plastic limit determination of fine-grained soils. *Geosciences Switzerland*, 11 (6), <https://doi.org/10.3390/geosciences11060247>.

Persistent Link:

<https://hdl.handle.net/11343/281054>

License:

[CC BY](#)

Technical Note

Reappraisal of the ASTM/AASHTO Standard Rolling Device Method for Plastic Limit Determination of Fine-Grained Soils

Amin Soltani ^{1,2,*}  and Brendan C. O’Kelly ³ 

- ¹ School of Engineering, IT and Physical Sciences, Federation University, Churchill, VIC 3842, Australia
² Department of Infrastructure Engineering, The University of Melbourne, Parkville, VIC 3010, Australia
³ Department of Civil, Structural and Environmental Engineering, Trinity College Dublin, D02 PN40 Dublin, Ireland; bokelly@tcd.ie
* Correspondence: a.soltani@federation.edu.au

Abstract: Given its apparent limitations, various attempts have been made to develop alternative testing approaches to the standardized rolling-thread plastic limit (PL_{RT}) method (for fine-grained soils), targeting higher degrees of repeatability and reproducibility. Among these, device-rolling techniques, including the method described in ASTM D4318/AASHTO T90 standards, based on original work by Bobrowski and Griekspoor (BG) and which follows the same basic principles as the standard thread-rolling (by hand) test, have been highly underrated by some researchers. To better understand the true potentials and/or limitations of the BG method for soil plasticity determination (i.e., PL_{BG}), this paper presents a critical reappraisal of the PL_{RT} – PL_{BG} relationship using a comprehensive statistical analysis performed on a large and diverse database of 60 PL_{RT} – PL_{BG} test pairs. It is demonstrated that for a given fine-grained soil, the BG and RT methods produce essentially similar PL values. The 95% lower and upper (water content) statistical agreement limits between PL_{BG} and PL_{RT} were, respectively, obtained as -5.03% and $+4.51\%$, and both deemed “statistically insignificant” when compared to the inductively-defined reference limit of $\pm 8\%$ (i.e., the highest possible difference in PL_{RT} based on its repeatability, as reported in the literature). Furthermore, the likelihoods of PL_{BG} underestimating and overestimating PL_{RT} were 50% and 40%, respectively; debunking the notion presented by some researchers that the BG method generally tends to greatly underestimate PL_{RT} . It is also shown that the degree of underestimation/overestimation does not systematically change with changes in basic soil properties; suggesting that the differences between PL_{BG} and PL_{RT} are most likely random in nature. Compared to PL_{RT} , the likelihood of achieving consistent soil classifications employing PL_{BG} (along with the liquid limit) was shown to be 98%, with the identified discrepancies being cases that plot relatively close to the A-Line. As such, PL_{BG} can be used with confidence for soil classification purposes.

Keywords: fine-grained soil; liquid limit; plastic limit; soil classification; statistical agreement limit; thread-rolling device



Citation: Soltani, A.; O’Kelly, B.C. Reappraisal of the ASTM/AASHTO Standard Rolling Device Method for Plastic Limit Determination of Fine-Grained Soils. *Geosciences* **2021**, *11*, 247. <https://doi.org/10.3390/geosciences11060247>

Academic Editors: Salvatore Grasso and Jesus Martinez-Frias

Received: 21 May 2021

Accepted: 4 June 2021

Published: 6 June 2021

Publisher’s Note: MDPI stays neutral with regard to jurisdictional claims in published maps and institutional affiliations.



Copyright: © 2021 by the authors. Licensee MDPI, Basel, Switzerland. This article is an open access article distributed under the terms and conditions of the Creative Commons Attribution (CC BY) license (<https://creativecommons.org/licenses/by/4.0/>).

1. Introduction

Since their inception in the early 1910s, the liquid limit (LL) and plastic limit (PL) remain among the most commonly specified soil parameters in geotechnical engineering practice. These limits, originally introduced by Atterberg [1,2] and later standardized for use in geoenvironmental applications by Terzaghi [3,4] and Casagrande [5,6], describe changes in the consistency states (and hence mechanical behavior) of fine-grained soils with respect to variations in water content. The LL and PL, together with their arithmetic difference, the plasticity index (PI), have been successfully incorporated into the soil mechanics framework, serving a variety of useful purposes, including their adoption for routine soil classification purposes [7–10], as well as their widespread applications for predicting useful soil properties (e.g., compactability, permeability, compressibility, and

shear strength) for performing preliminary geotechnical designs [11–25]. Both the LL and PL tests are conventionally performed on the soil fraction passing the 425- μm sieve size.

The LL is conceptually defined as the water content at which fine-grained soil transitions from the liquid state to the plastic state. The LL magnitude is strongly dependent on the soil gradation, composition, mineralogical properties (of the clay fraction), and the quantity of interlayer water in the case of expanding clay minerals such as montmorillonite [26–28]. The Casagrande percussion-cup (PC) and the fall-cone (FC) tests are standard methods conventionally employed for LL determinations of fine-grained soils; the former being the preferred method in the USA [29,30], while the latter is favored in the UK [31,32], the Eurocodes, and elsewhere, including Australia [33]. Since no sudden definite change in behavior can be associated with the transition from liquid to plastic consistency states, the LL is determined as the water content corresponding to an arbitrarily chosen (low) shear strength on a continuum of ever-weakening behavior with increasing water content [34]. As such, the designation of the LL for a given fine-grained soil is somewhat arbitrary, with its value also dependent on the measurement technique (PC or FC apparatus), the definition for LL determination, and the testing standard employed [34]. For instance, the standard PC test (ASTM D4318 [30]) involves manipulating the water content of a soil specimen such that 25 blows of the specimen cup would be required for the closure of a standard groove (formed by drawing a standard grooving tool through the soil paste specimen on a line joining the highest point to the lowest point on the rim of the cup) over a length of 13 mm. As it is almost impossible to achieve the required groove-closure condition at exactly 25 blows, several trials at varying water contents w and corresponding numbers of blows N_b (for groove-closure) are performed, and the results are plotted in the semi-logarithmic space of $w:\log_{10}N_b$, from which the water content corresponding to $N_b = 25$, defined as the LL_{PC} , can be determined from the fitted best-fit line. Following the British Standard (BS) FC test (BS 1377–2 [31]), the LL is defined as the water content for which an 80 g–30° cone, with its tip just contacting the top surface of the soil paste specimen, is able to penetrate into the specimen to a depth of $d = 20$ mm before coming to rest; this state equating to an undrained shear strength value of approximately 1.7 kPa [14,34,35]. Data from several trials for a range of water contents covering $d = 15$ –25 mm are plotted in the arithmetic space of $w:d$, from which the water content corresponding to $d = 20$ mm, defined as the LL_{FC} following the BS, can be established.

The PL of a fine-grained soil material is recognized as the water content at which it transitions from plastic (or ductile) to brittle consistency. The rolling-thread (RT) method is conventionally employed for PL determination of fine-grained soils. Following the RT test, the water content at which a uniform thread formed from the soil, with a starting diameter of about 6 mm, first begins to crumble (likely due to air entry or cavitation within the soil thread [36]) when manually rolled out (by hand) on a glass plate to about 3.0 mm [31,32,37] or 3.2 mm [30,38] in diameter is defined as the PL_{RT} . Unlike the LL, which can be determined with confidence (with the FC test arguably producing higher degrees of repeatability and reproducibility), the standard (hand rolling) RT test can be associated with high degrees of subjective variability—that is, measuring the PL_{RT} (by hand-rolling) can be overly dependent on operator performance and judgments [39–44].

Given its apparent limitations, various attempts have been made to develop alternative testing approaches to the standard hand-rolling PL_{RT} method, targeting higher degrees of repeatability and reproducibility. Most suggestions in this context are essentially strength-based methods, executed using FC or reverse-extrusion devices, which mainly work on the premise of associating the PL_{RT} with a set value of undrained shear strength (a more detailed review of these methods is given in O’Kelly et al. [34], Vardanega and Haigh [45] and O’Kelly [46,47]). However, several studies have demonstrated that when considering a range of different fine-grained soils, the PL_{RT} (onset of brittleness) does not correspond to a fixed value of undrained shear strength [22,34,36,37,48–50]. In other words, while strength-based “PL” determination methods arguably benefit from higher degrees of repeatability and reproducibility, they cannot replicate the standard PL_{RT} testing condition,

which assesses soil plasticity (toughness) behavior/properties. Attempts to improve on the standard hand-rolling PL test itself, particularly in terms of reproducibility by minimizing the uncertainties associated with the rolling out (by hand) procedure (i.e., rate of rolling, the hand pressure and/or the initial and final thread diameter criteria), include various device-rolling techniques [51–58]. These methods mainly follow the same basic principles as the standard (hand-rolling) RT test. In particular, the device-rolling technique proposed by Bobrowski and Griekspoor (BG) [52] (a thread-rolling device consisting of two acrylic flat plates covered with unglazed paper), which was subsequently adopted as an alternate PL_{RT} determination method in the USA (by ASTM D4318 [30] and AASHTO T90 [38]; see Figure 1), appears to be highly underrated and hence demands further attention. In performing the ASTM/AASHTO rolling device method for PL determination (i.e., PL_{BG}), downward force is simultaneously applied (via the rigid top plate) to the soil thread with the back and forth rolling motion, until the top plate comes into contact with the 3.2-mm-deep side rails. Apart from this standardized method, none of the other proposed device-rolling techniques have been adopted more widely. Note that, in addition to device-rolling techniques, other methods developed based on the “onset of brittleness” concept for improved PL determination include the likes of the indentation test [59] and the thread-bending technique [60–62].

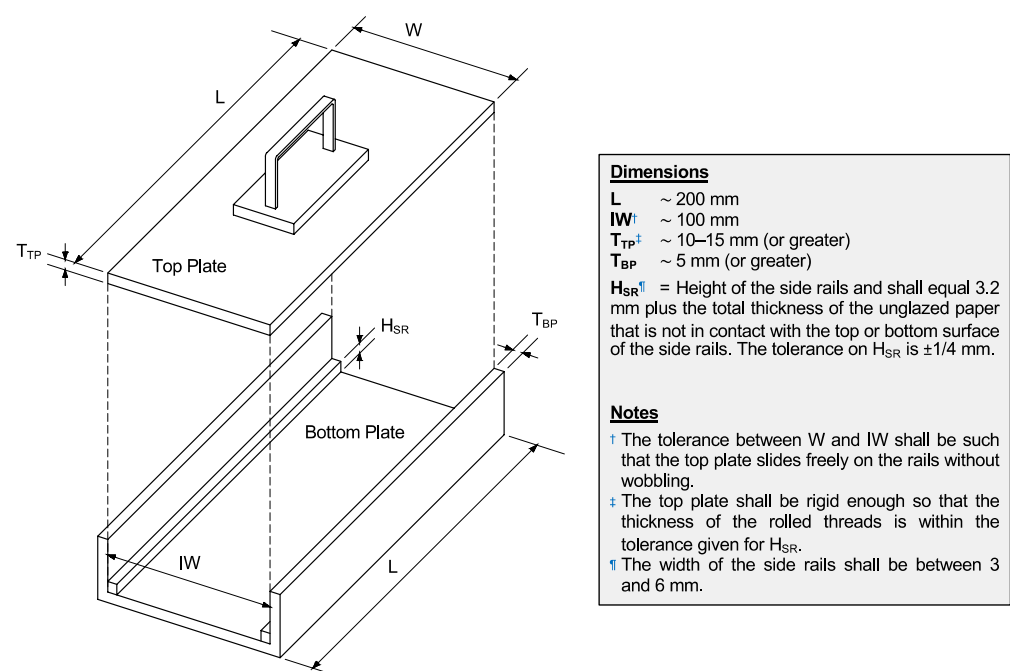

Figure 1. Schematic illustration of the ASTM/AASHTO rolling device for PL determination (modified from [30]).

Further, there seems to exist a general belief among some researchers that the PL deduced using the BG-type rolling device (i.e., PL_{BG}) generally tends to (greatly) underestimate the PL_{RT} ; possibly due to heterogeneity of the soil thread caused by the contacting paper during the rolling out procedure (i.e., the outside of the soil thread becoming drier than its core) [58,63,64]. Although the published results to support this claim (i.e., typically $PL_{BG} < PL_{RT}$) are limited, and mainly derived from statistical analyses performed on small (and rather uniform) datasets, this preconception appears to have hindered the more widespread acceptance of the PL_{BG} testing approach (as presented in ASTM D4318 [30] and AASHTO T90 [38] standards), as well as its adoption in other PL determination standards; this alone highlighting the need for further investigations.

To better understand the true potentials and/or limitations of the ASTM/AASHTO device-rolling technique for soil plasticity determination, this study presents a critical

statistical appraisal of the $PL_{RT}-PL_{BG}$ relationship (employing the largest and most diverse $PL_{RT}-PL_{BG}$ database compared to those previously investigated in the literature). The validity of the PL_{BG} parameter is investigated by quantifying and critically examining its statistical level of agreement with the standard PL_{RT} . An attempt, for the first time, is also made to assess the accuracy of PL_{BG} in the context of soil classification (based on the BS soil plasticity-chart framework).

2. Database of $PL_{RT}-PL_{BG}$ Tests

A large and diverse database of 60 $PL_{RT}-PL_{BG}$ test results, conducted on 60 fine-grained soils (obtained from natural deposits, as well as commercially produced kaolinite- and bentonite-based blends), was assembled to examine the level of agreement between the PL_{RT} and PL_{BG} measurements. A detailed description of the assembled database is presented in Table 1. The database consisted of 51 $PL_{RT}-PL_{BG}$ data pairs sourced from the research literature (designated by Test IDs S1–S51) [52,63–65], as well as original test results of nine fine-grained soils investigated by the authors (Test IDs S52–S60). As demonstrated in Table 1, the database soils, in addition to their geographical diversity, cover reasonably wide ranges of surface texture, plasticity and mineralogical properties—that is, f_{clay} ($<2 \mu m$) = 8.9–59.5%, f_{silt} (2–75 μm) = 7.0–72.7%, LL_{FC} = 24.6–141.1%, PL_{RT} = 11.9–53.4%, $PI_{FC-RT} = LL_{FC} - PL_{RT}$ = 8.1–101.6%, and $A_{FC} = PI_{FC-RT}/f_{clay} = 0.49-1.85$ (where f_{clay} , f_{silt} , LL_{FC} , PL_{RT} , PI_{FC-RT} and A_{FC} denote clay content, silt content, BS fall-cone liquid limit, standard rolling-thread plastic limit, plasticity index deduced from the FC and RT test results, and soil activity index, respectively). Since the assembled database employed in this investigation is, to date, the largest and most diverse of its kind, it provides a solid basis for a critical statistical appraisal of the $PL_{RT}-PL_{BG}$ relationship.

Figure 2 illustrates the database soils, with the exception of S18–S22 (for which the LL_{PC} or LL_{FC} values were not reported), plotted on the BS soil plasticity chart. As demonstrated in this figure, all of the investigated soil materials plot below the U-Line, indicating that the assembled database conforms to the general correlation framework proposed by Casagrande [66]. Following the BS soil plasticity-chart classification framework, employing their LL_{PC} or LL_{FC} and PL_{RT} values, the database soils consisted of 46 clays and 9 silts (note that soils S18–S22 could not be classified since their LL_{PC} or LL_{FC} values were not reported), covering all of the five soil plasticity level classes defined in BS 5930 [9].

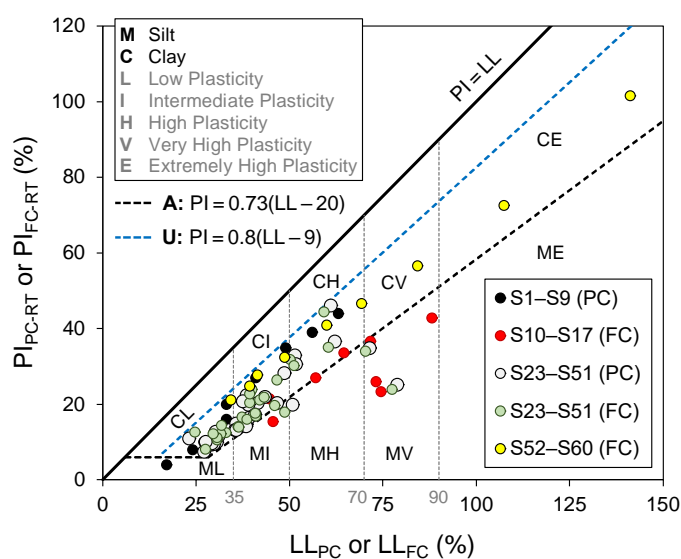

Figure 2. The database soils (excluding S18–S22 for which the LL_{PC} or LL_{FC} values were not reported) plotted on the standard soil plasticity chart, as per BS 5930 [9].

Table 1. Detailed description of the compiled database of PL_{RT}–PL_{BG} test results.

Source	Source ID/Description	New ID	f_{clay} (%)	f_{silt} (%)	LL _{PC} (%)	LL _{FC} (%)	PL _{RT} (%)	PL _{BG} (%)	PI _{PC-RT} (%)	PI _{FC-RT} (%)	A _{PC}	A _{FC}
[52]	1	S1	—	—	17.0	—	13.0	13.0	4.0	—	—	—
	2	S2	—	—	24.0	—	16.0	14.0	8.0	—	—	—
	3	S3	—	—	27.0	—	17.0	15.0	10.0	—	—	—
	4	S4	—	—	33.0	—	17.0	17.0	16.0	—	—	—
	5	S5	—	—	33.0	—	13.0	13.0	20.0	—	—	—
	6	S6	—	—	41.0	—	14.0	13.0	27.0	—	—	—
	7	S7	—	—	49.0	—	14.0	14.0	35.0	—	—	—
	8	S8	—	—	56.0	—	17.0	16.0	39.0	—	—	—
	9	S9	—	—	63.0	—	19.0	18.0	44.0	—	—	—
[63]	Sample A	S10	—	—	—	73.1	47.1	43.4	—	26.0	—	—
	Sample B	S11	—	—	—	56.9	29.8	29.0	—	27.1	—	—
	Sample C	S12	—	—	—	64.5	30.9	31.8	—	33.6	—	—
	Sample D	S13	—	—	—	45.5	30.0	27.0	—	15.5	—	—
	Sample E	S14	—	—	—	44.6	23.2	21.0	—	21.4	—	—
	Sample F	S15	—	—	—	74.4	51.1	45.0	—	23.3	—	—
	Sample G	S16	—	—	—	88.1	45.2	38.0	—	42.9	—	—
	Sample H	S17	—	—	—	71.6	34.9	45.0	—	36.7	—	—
[64]	Agronomy Farm	S18	13.0	63.0	—	—	23.0	20.0	—	—	—	—
	Lalmal	S19	26.0	40.0	—	—	21.1	21.0	—	—	—	—
	Gaghra	S20	28.4	66.0	—	—	25.3	24.3	—	—	—	—
	Bhaluka	S21	43.0	38.0	—	—	27.8	26.5	—	—	—	—
	Bhoraduba	S22	44.0	36.0	—	—	29.9	30.0	—	—	—	—
[65]	DK2	S23	22.0	7.0	41.4	42.0	20.9	23.1	20.5	21.1	0.93	0.96
	DK3	S24	28.9	8.8	48.5	46.6	20.2	22.5	28.3	26.4	0.98	0.91
	DK4	S25	44.6	12.2	62.0	60.4	25.3	28.9	36.7	35.1	0.82	0.79
	CH1	S26	22.0	53.7	35.6	37.2	20.6	19.7	15.0	16.6	0.68	0.75
	CH2	S27	48.1	35.8	78.7	77.4	53.4	54.3	25.3	24.0	0.53	0.50
	CH3	S28	59.5	36.6	71.3	70.3	36.3	33.7	35.0	34.0	0.59	0.57
	CH4	S29	16.7	29.6	29.1	30.6	19.6	19.3	9.5	11.0	0.57	0.66
	CH5	S30	26.6	41.3	38.9	39.3	18.9	19.3	20.0	20.4	0.75	0.77
	DE1	S31	22.0	25.4	30.4	32.9	20.4	18.9	10.0	12.5	0.45	0.57
	DE2	S32	13.7	25.9	27.0	27.5	19.4	20.3	7.6	8.1	0.55	0.59
	DE3	S33	50.1	26.5	51.3	50.1	18.3	18.5	33.0	31.8	0.66	0.63
	DE4	S34	23.5	33.3	39.0	38.6	22.5	23.8	16.5	16.1	0.70	0.69

Table 1. Cont.

Source	Source ID/Description	New ID	f_{clay} (%)	f_{silt} (%)	LL _{PC} (%)	LL _{FC} (%)	PL _{RT} (%)	PL _{BG} (%)	PI _{PC-RT} (%)	PI _{FC-RT} (%)	A_{PC}	A_{FC}
[65]	BE1	S35	13.8	60.1	30.9	31.6	19.3	19.3	11.6	12.3	0.84	0.89
	BE2	S36	13.3	65.2	30.1	31.7	17.3	19.0	12.8	14.4	0.96	1.08
	BE3	S37	10.5	69.7	29.6	30.6	20.0	20.2	9.6	10.6	0.91	1.01
	BE4	S38	12.0	67.3	29.0	30.5	19.3	20.0	9.7	11.2	0.81	0.93
	PK1	S39	17.9	28.4	27.5	29.5	17.3	17.2	10.2	12.2	0.57	0.68
	PK2	S40	24.4	72.7	38.3	40.9	24.0	23.0	14.3	16.9	0.59	0.69
	PK3	S41	46.3	44.7	51.6	51.1	20.9	20.6	30.7	30.2	0.66	0.65
	PK4	S42	21.8	26.8	23.0	24.6	11.9	12.6	11.1	12.7	0.51	0.58
	PK5	S43	31.0	30.5	38.4	39.9	15.9	18.7	22.5	24.0	0.73	0.77
	PK6	S44	30.8	40.2	37.4	39.3	16.5	19.3	20.9	22.8	0.68	0.74
	UA1	S45	22.2	27.9	35.3	36.2	22.0	21.8	13.3	14.2	0.60	0.64
	UA2	S46	8.9	9.4	35.6	36.3	22.3	24.2	13.3	14.0	1.49	1.57
	GH	S47	41.4	8.3	61.0	59.2	14.8	13.7	46.2	44.4	1.12	1.07
	CN1	S48	28.6	36.3	40.6	40.8	23.2	22.3	17.4	17.6	0.61	0.62
	CN2	S49	12.0	51.0	43.3	43.2	21.3	21.4	22.0	21.9	1.83	1.83
	NO	S50	23.6	36.0	46.6	45.9	26.2	26.2	20.4	19.7	0.86	0.83
JP	S51	33.6	26.3	50.7	48.6	30.7	30.9	20.0	17.9	0.60	0.53	
Present Study	Kilkenny, South Australia	S52	43.0	37.0	—	34.3	13.1	14.0	—	21.2	—	0.49
	Inkerman, South Australia	S53	37.0	32.0	—	39.3	14.4	12.6	—	24.9	—	0.67
	Kaolinite	S54	49.8	49.4	—	41.4	13.6	13.3	—	27.8	—	0.56
	Kaolinite + 5% Bentonite	S55	50.4	48.7	—	48.7	16.2	17.4	—	32.5	—	0.64
	Kaolinite + 10% Bentonite	S56	51.0	48.1	—	59.9	19.0	22.1	—	40.9	—	0.80
	Kaolinite + 15% Bentonite	S57	51.7	47.4	—	69.3	22.7	20.3	—	46.6	—	0.90
	Kaolinite + 20% Bentonite	S58	52.3	46.7	—	84.3	27.7	24.4	—	56.6	—	1.08
	Kaolinite + 30% Bentonite	S59	53.6	45.3	—	107.4	34.8	36.0	—	72.6	—	1.35
Kaolinite + 40% Bentonite	S60	54.8	44.0	—	141.1	39.5	35.6	—	101.6	—	1.85	

Note: f_{clay} and f_{silt} = clay (<2 μm) and silt (2–75 μm) contents, respectively; LL_{PC} and LL_{FC} = percussion-cup and BS fall-cone liquid limits, respectively; PL_{RT} and PL_{BG} = standard thread-rolling (by hand) and device-rolling plastic limits, respectively; PI_{PC-RT} = plasticity index deduced from the PC and RT tests (=LL_{PC} – PL_{RT}); PI_{FC-RT} = plasticity index deduced from the FC and RT tests (=LL_{FC} – PL_{RT}); and A_{PC} or A_{FC} = soil activity index (defined as the PI-to-clay content ratio and hence calculated as $A_{\text{PC}} = \text{PI}_{\text{PC-RT}}/f_{\text{clay}}$ or $A_{\text{FC}} = \text{PI}_{\text{FC-RT}}/f_{\text{clay}}$).

3. Results and Discussion

3.1. Statistical Appraisal of the PL_{RT} – PL_{BG} Relationship

Figure 3a illustrates the variations of PL_{RT} against PL_{BG} for the compiled database of $N = 60$ fine-grained soils. As is evident from this figure, the two PL measurement methods are strongly correlated with each other, exhibiting a linear relationship in the form of $PL_{RT} = 1.01 PL_{BG} - 4.66 \times 10^{-2}$ (with $R^2 = 0.943$), essentially suggesting that $PL_{RT} \approx PL_{BG}$. The average error associated with the $PL_{RT} \approx PL_{BG}$ trendline shown in Figure 3a was quantified by the mean absolute percentage error (MAPE calculated by Equation (1) [67]) and the normalized root-mean-squared error (NRMSE calculated by Equation (2,3) [68]), which resulted in MAPE = 6.5% and NRMSE = 5.9% (note that MAPE and NRMSE are both dimensionless quantities expressed in %). These values, which are lower than the usual 5–10% reference limit, indicate an average variation of 5.9–6.5% between the PL_{RT} and PL_{BG} measurements.

$$MAPE = \frac{1}{N} \sum_{n=1}^N \left| \frac{PL_{RT(n)} - PL_{BG(n)}}{PL_{RT(n)}} \right| \times 100\% \quad (1)$$

$$NRMSE = \frac{RMSE}{PL_{RT(max)} - PL_{RT(min)}} \times 100\% \quad (2)$$

$$RMSE = \sqrt{\frac{1}{N} \sum_{n=1}^N (PL_{RT(n)} - PL_{BG(n)})^2} \quad (3)$$

where RMSE = root-mean-squared error (in % water content); $PL_{RT(max)}$ and $PL_{RT(min)}$ = maximum and minimum of PL_{RT} data, respectively; n = index of summation; and N = number of investigated PL_{RT} – PL_{BG} test pairs ($N = 60$).

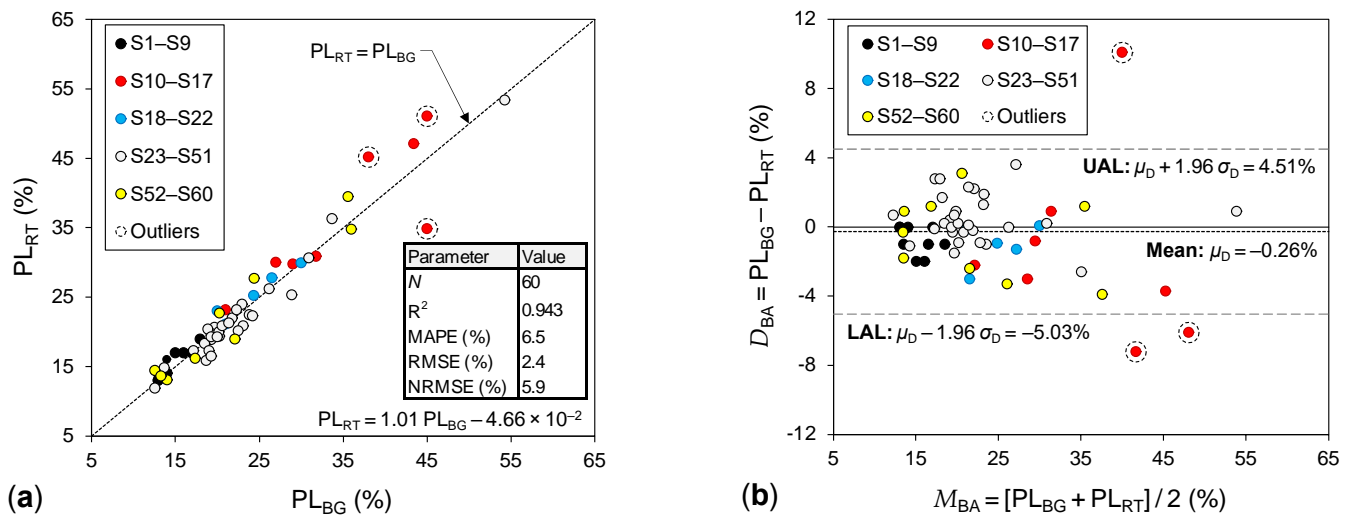

Figure 3. Comparison of PL_{RT} and PL_{BG} for the compiled database of $N = 60$ fine-grained soils: (a) PL_{RT} – PL_{BG} correlation plot; and (b) PL_{BG} – PL_{RT} Bland–Altman plot. Note: LAL and UAL denote lower and upper agreement limits, respectively.

The excellent graphical correlation (high R^2) and low MAPE or NRMSE values obtained for the $PL_{RT} \approx PL_{BG}$ trendline outlined in Figure 3a would normally lead to accepting the PL_{BG} as a suitable replacement for the PL_{RT} . However, the statistical “limits of agreement” between these two PL measurement methods should also be quantified (and critically examined) to better perceive the true implications of the PL_{BG} parameter for routine geotechnical applications, including its potential use in the many well-established empirical correlations reported between the PL_{RT} or the PL_{RT} -deduced PI and other geomechanical parameters (e.g., shear strength, compressibility, permeability, and compactability).

This was achieved by performing the Bland–Altman (BA) analysis [69], which involves developing an $x:y$ scatter plot, with the y -axis representing the difference between the two measurement techniques (i.e., $D_{BA} = PL_{BG} - PL_{RT}$) and the x -axis showing the average of these measurements (i.e., $M_{BA} = [PL_{BG} + PL_{RT}]/2$). Following the BA framework, the 95% lower and upper agreement limits between the PL_{BG} and PL_{RT} can be, respectively, defined as $LAL = \mu_D - 1.96 \sigma_D$ and $UAL = \mu_D + 1.96 \sigma_D$ (where μ_D and σ_D denote the arithmetic mean and standard deviation of the $D_{BA} = PL_{BG} - PL_{RT}$ data, respectively). Note that the calculated LAL and UAL must be examined against an inductively-defined limit, often selected as the highest possible (water content) difference/variation in the standard measurement method (i.e., PL_{RT}) based on its repeatability [65]. A review of the research literature indicates that the maximum variation in the PL_{RT} for a given fine-grained soil (accounting for measurement variations across multiple operators) can be conservatively taken as $\pm 8\%$ [34]. Accordingly, this water content limit was considered as a point of reference to examine the LAL and UAL obtained in the present investigation.

The BA plot for the $N = 60$ pairs of PL_{BG} – PL_{RT} data is provided in Figure 3b. The mean of differences between PL_{BG} and PL_{RT} was shown to be $\mu_D = -0.26\%$, implying that the PL_{BG} is on average 0.26% (water content) lower than the PL_{RT} . The 95% agreement limits between PL_{BG} and PL_{RT} were calculated as $LAL = -5.03\%$ and $UAL = +4.51\%$, indicating that 95% of the differences between these two PL measurement methods lie between these lower and upper water content limits, both of which are less than (in terms of magnitude) the chosen reference limit (for the present investigation) of $\pm 8\%$. This implies that the BG-based and RT methods are expected to produce similar PL values for a given fine-grained soil investigated under identical testing conditions—that is, the ASTM/AASHTO rolling device method can be deemed as a reliable PL determination technique capable of alleviating the labor, time and possibly also some of the variability associated with the conventional RT test. Referring to Figure 3b; those data pairs that plot above/below the 95% agreement limits (which may count as potential outliers) were associated with $D_{BA} = PL_{BG} - PL_{RT} = -6.1\%$, -7.2% and $+10.1\%$ (for S15–S17, respectively), the magnitudes of which are still less than (or on par with) the reference water content limit of $\pm 8\%$.

Referring to Figure 3b; the likelihoods of underestimating (i.e., $PL_{BG} < PL_{RT}$) and overestimating (i.e., $PL_{BG} > PL_{RT}$) the PL_{RT} can be calculated as 50% and 40%, respectively; allowing one to simply debunk the notion presented by some researchers that the BG method generally tends to greatly underestimate the PL_{RT} [58,63,64]. To further examine this critical aspect, and to investigate whether the degree of underestimation or overestimation is systematically related to fundamental soil properties (i.e., plasticity level class, clay and silt contents, and soil mineralogy), the PL_{BG} -to- PL_{RT} ratio is plotted against LL_{PC} or LL_{FC} , f_{clay} , f_{silt} , and A_{PC} or A_{FC} (see Figure 4). As is evident from this figure, the PL_{BG}/PL_{RT} ratio does not systematically increase or decrease with changes in soil type (or behavior); suggesting that the differences between the PL_{BG} and PL_{RT} measurements are most likely random in nature.

In view of the potential outlier D_{BA} ($= PL_{BG} - PL_{RT}$) values obtained for S15–S17 (all classified as silt with very high plasticity, MV, as per BS 5930 [9]), one may postulate that the BG-based method is potentially less workable for less-cohesive soils (or silts). However, given that the bulk of the compiled database consisted of clays, and the fact that other silts within the database (i.e., S1, S10, S13, S27, S28 and S51) produced acceptable D_{BA} values (i.e., $|D_{BA}| < 8\%$), this early postulation should be taken with caution, demanding further investigation.

3.2. Use of PL_{BG} for Soil Classification

The LL (i.e., LL_{PC} or LL_{FC}), together with the PI (i.e., $PI_{PC-RT} = LL_{PC} - PL_{RT}$ or $PI_{FC-RT} = LL_{FC} - PL_{RT}$), are commonly employed with the Casagrande-style plasticity chart for classifying fine-grained soils [7–10]. Accordingly, any alternate PL_{RT} measurement technique, such as the BG-based method, is expected to produce reliable soil classifications.

To the authors’ knowledge, this critical requirement has not yet been examined (nor discussed) for the PL_{BG} parameter. Herein, an attempt is made to examine the validity of the PL_{BG} parameter in the context of soil classification using the BS soil plasticity-chart framework, as per BS 5930 [9].

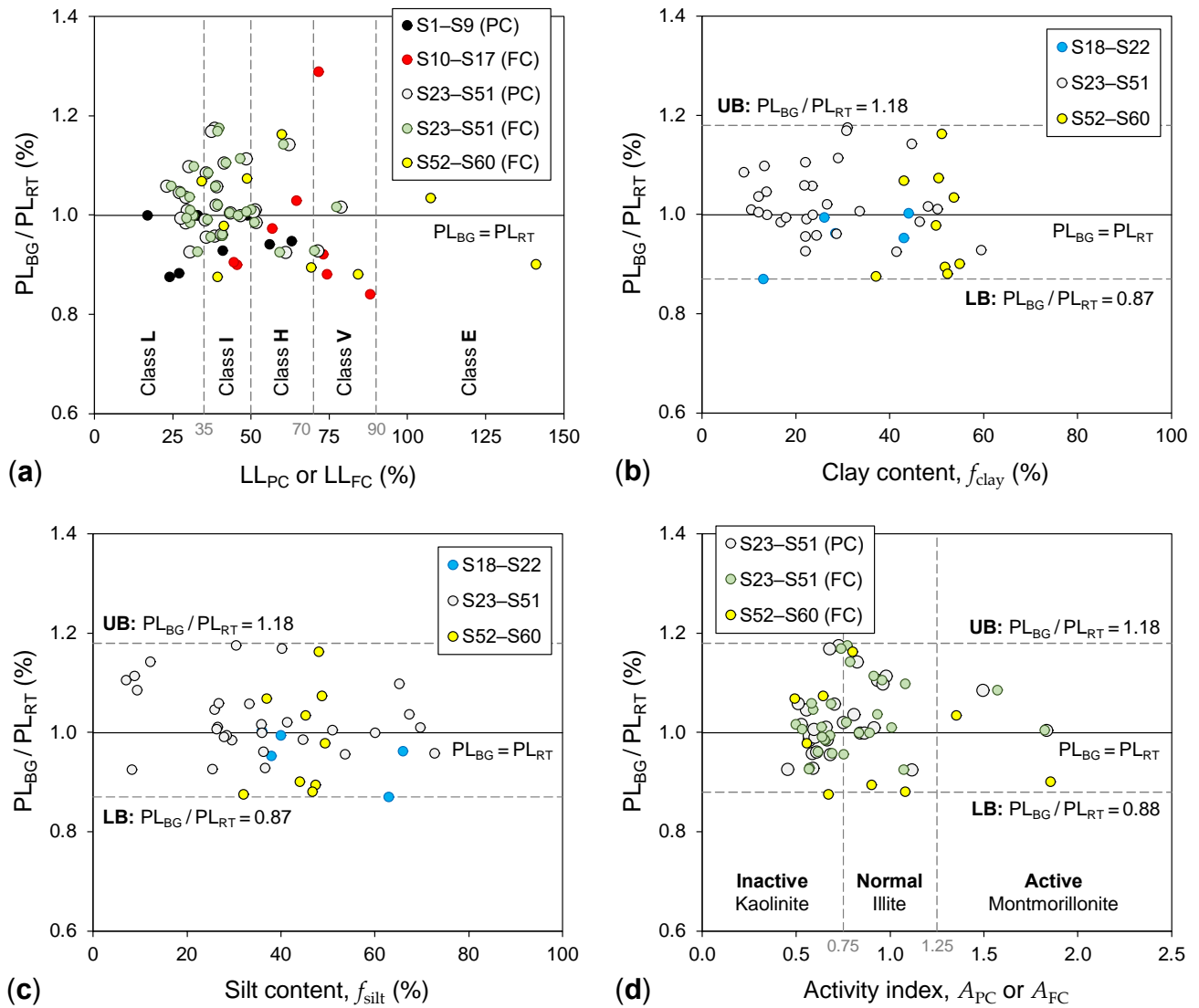

Figure 4. Variations of the PL_{BG} -to- PL_{RT} ratio against fundamental soil properties for the compiled database: (a) LL_{PC} or LL_{FC} ; (b) f_{clay} ; (c) f_{silt} ; and (d) A_{PC} or A_{FC} . Note: LB and UB denote lower and upper PL_{BG}/PL_{RT} boundaries, respectively; and L, I, H, V and E represent low, intermediate, high, very high and extremely high plasticity level classes, respectively.

Figure 5 illustrates the variations of the RT-deduced PI (PI_{PC-RT} or PI_{FC-RT} , written as $PI_{PC/FC-RT}$ for simplicity) against the BG-deduced PI (PI_{PC-BG} or PI_{FC-BG} ; i.e., $PI_{PC/FC-BG}$) for the compiled database (excluding S18–S22 for which the LL_{PC} or LL_{FC} values were not reported). As expected, the two PI parameters are strongly correlated, exhibiting a linear relationship in the form of $PI_{PC/FC-RT} = 0.96 PI_{PC/FC-BG} + 1.01$ (with $R^2 = 0.980$), implying that the RT- and BG-deduced PI parameters are approximately equal. Note that the MAPE and NRMSE associated with $PI_{PC/FC-RT} \approx PI_{PC/FC-BG}$ were shown to be 6.6% and 2.3%, respectively.

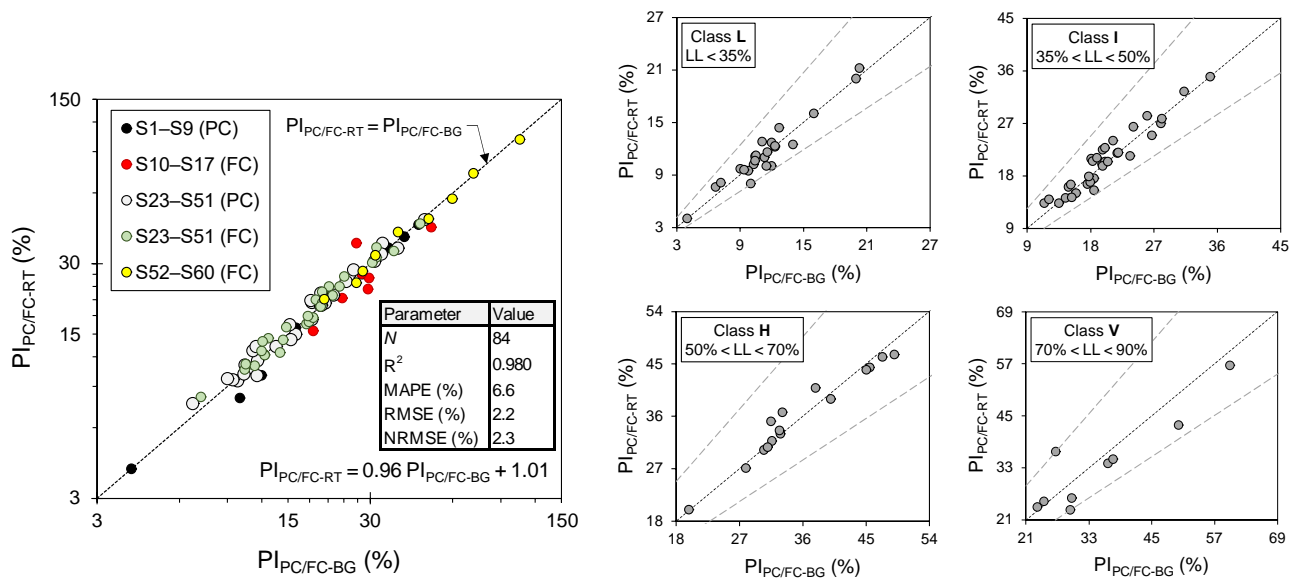

Figure 5. Variations of the RT-deduced PI ($PI_{PC/FC-RT}$) against the BG-deduced PI ($PI_{PC/FC-BG}$) for the compiled database (excluding S18–S22 for which the LL_{PC} or LL_{FC} values were not reported). Note: L, I, H and V represent low, intermediate, high and very high plasticity level classes, respectively.

Making use of the LL_{PC} and/or LL_{FC} , together with the BG-deduced PI, only two cases (out of 84 examined)—namely, S16 employing LL_{FC} and S28 employing LL_{PC} —were shown to produce classifications different from those obtained based on the RT-deduced PI; that is, in terms of deducing clay instead of silt when plotted on the BS soil plasticity chart (see Table 2). Overall, this implies that compared to PL_{RT} , the likelihood of achieving consistent soil classifications employing the PL_{BG} parameter stands at 98%. Quite clearly, if the potential errors/variations associated with the PL_{RT} measurements are also considered in the analysis, the two classification discrepancies can be deemed acceptable; especially when considering the small actual vertical distance for S16 and S28 from the A-Line, which can be calculated as $D_A = PI_{PC/FC-RT} - 0.73 (LL_{PC/FC} - 20) = -6.81\%$ and -2.45% , respectively. In view of these results, it is concluded that the PL_{BG} parameter can be used with confidence for routine soil classification purposes.

Table 2. Summary of the soil classification results employing PL_{RT} and PL_{BG} for the compiled database (excluding S18–S22 for which the LL_{PC} or LL_{FC} values were not reported).

ID	LL_{PC} (%)	LL_{FC} (%)	PL_{RT} (%)	PL_{BG} (%)	PI_{PC-RT} (%)	PI_{FC-RT} (%)	USCS _{PC-RT}	USCS _{FC-RT}	PI_{PC-BG} (%)	PI_{FC-BG} (%)	USCS _{PC-BG}	USCS _{FC-BG}
S1	17.0	—	13.0	13.0	4.0	—	ML	—	4.0	—	ML	—
S2	24.0	—	16.0	14.0	8.0	—	CL	—	10.0	—	CL	—
S3	27.0	—	17.0	15.0	10.0	—	CL	—	12.0	—	CL	—
S4	33.0	—	17.0	17.0	16.0	—	CL	—	16.0	—	CL	—
S5	33.0	—	13.0	13.0	20.0	—	CL	—	20.0	—	CL	—
S6	41.0	—	14.0	13.0	27.0	—	CI	—	28.0	—	CI	—
S7	49.0	—	14.0	14.0	35.0	—	CI	—	35.0	—	CI	—
S8	56.0	—	17.0	16.0	39.0	—	CH	—	40.0	—	CH	—
S9	63.0	—	19.0	18.0	44.0	—	CH	—	45.0	—	CH	—
S10	—	73.1	47.1	43.4	—	26.0	—	MV	—	29.7	—	MV
S11	—	56.9	29.8	29.0	—	27.1	—	CH	—	27.9	—	CH
S12	—	64.5	30.9	31.8	—	33.6	—	CH	—	32.7	—	CH
S13	—	45.5	30.0	27.0	—	15.5	—	MI	—	18.5	—	MI
S14	—	44.6	23.2	21.0	—	21.4	—	CI	—	23.6	—	CI
S15	—	74.4	51.1	45.0	—	23.3	—	MV	—	29.4	—	MV
S16	—	88.1	45.2	38.0	—	42.9	—	MV	—	50.1	—	CV
S17	—	71.6	34.9	45.0	—	36.7	—	MV	—	26.6	—	MV
S23	41.4	42.0	20.9	23.1	20.5	21.1	CI	CI	18.3	18.9	CI	CI

Table 2. Cont.

ID	LL _{PC} (%)	LL _{FC} (%)	PL _{RT} (%)	PL _{BG} (%)	PI _{PC-RT} (%)	PI _{FC-RT} (%)	USCS _{PC-RT}	USCS _{FC-RT}	PI _{PC-BG} (%)	PI _{FC-BG} (%)	USCS _{PC-BG}	USCS _{FC-BG}
S24	48.5	46.6	20.2	22.5	28.3	26.4	CI	CI	26.0	24.1	CI	CI
S25	62.0	60.4	25.3	28.9	36.7	35.1	CH	CH	33.1	31.5	CH	CH
S26	35.6	37.2	20.6	19.7	15.0	16.6	CI	CI	15.9	17.5	CI	CI
S27	78.7	77.4	53.4	54.3	25.3	24.0	MV	MV	24.4	23.1	MV	MV
S28	71.3	70.3	36.3	33.7	35.0	34.0	MV	MV	37.6	36.6	CV	MV
S29	29.1	30.6	19.6	19.3	9.5	11.0	CL	CL	9.8	11.3	CL	CL
S30	38.9	39.3	18.9	19.3	20.0	20.4	CI	CI	19.6	20.0	CI	CI
S31	30.4	32.9	20.4	18.9	10.0	12.5	CL	CL	11.5	14.0	CL	CL
S32	27.0	27.5	19.4	20.3	7.6	8.1	CL	CL	6.7	7.2	CL	CL
S33	51.3	50.1	18.3	18.5	33.0	31.8	CH	CH	32.8	31.6	CH	CH
S34	39.0	38.6	22.5	23.8	16.5	16.1	CI	CI	15.2	14.8	CI	CI
S35	30.9	31.6	19.3	19.3	11.6	12.3	CL	CL	11.6	12.3	CL	CL
S36	30.1	31.7	17.3	19.0	12.8	14.4	CL	CL	11.1	12.7	CL	CL
S37	29.6	30.6	20.0	20.2	9.6	10.6	CL	CL	9.4	10.4	CL	CL
S38	29.0	30.5	19.3	20.0	9.7	11.2	CL	CL	9.0	10.5	CL	CL
S39	27.5	29.5	17.3	17.2	10.2	12.2	CL	CL	10.3	12.3	CL	CL
S40	38.3	40.9	24.0	23.0	14.3	16.9	CI	CI	15.3	17.9	CI	CI
S41	51.6	51.1	20.9	20.6	30.7	30.2	CH	CH	31.0	30.5	CH	CH
S42	23.0	24.6	11.9	12.6	11.1	12.7	CL	CL	10.4	12.0	CL	CL
S43	38.4	39.9	15.9	18.7	22.5	24.0	CI	CI	19.7	21.2	CI	CI
S44	37.4	39.3	16.5	19.3	20.9	22.8	CI	CI	18.1	20.0	CI	CI
S45	35.3	36.2	22.0	21.8	13.3	14.2	CI	CI	13.5	14.4	CI	CI
S46	35.6	36.3	22.3	24.2	13.3	14.0	CI	CI	11.4	12.1	CI	CI
S47	61.0	59.2	14.8	13.7	46.2	44.4	CH	CH	47.3	45.5	CH	CH
S48	40.6	40.8	23.2	22.3	17.4	17.6	CI	CI	18.3	18.5	CI	CI
S49	43.3	43.2	21.3	21.4	22.0	21.9	CI	CI	21.9	21.8	CI	CI
S50	46.6	45.9	26.2	26.2	20.4	19.7	CI	CI	20.4	19.7	CI	CI
S51	50.7	48.6	30.7	30.9	20.0	17.9	MH	MI	19.8	17.7	MH	MI
S52	—	34.3	13.1	14.0	—	21.2	—	CL	—	20.3	—	CL
S53	—	39.3	14.4	12.6	—	24.9	—	CI	—	26.7	—	CI
S54	—	41.4	13.6	13.3	—	27.8	—	CI	—	28.1	—	CI
S55	—	48.7	16.2	17.4	—	32.5	—	CI	—	31.3	—	CI
S56	—	59.9	19.0	22.1	—	40.9	—	CH	—	37.8	—	CH
S57	—	69.3	22.7	20.3	—	46.6	—	CH	—	49.0	—	CH
S58	—	84.3	27.7	24.4	—	56.6	—	CV	—	59.9	—	CV
S59	—	107.4	34.8	36.0	—	72.6	—	CE	—	71.4	—	CE
S60	—	141.1	39.5	35.6	—	101.6	—	CE	—	105.5	—	CE

Note: LL_{PC} and LL_{FC} = percussion-cup and BS fall-cone liquid limits, respectively; PL_{RT} and PL_{BG} = standard thread-rolling (by hand) and device-rolling plastic limits, respectively; PI_{PC-RT} = LL_{PC} - PL_{RT}; PI_{FC-RT} = LL_{FC} - PL_{RT}; PI_{PC-BG} = LL_{PC} - PL_{BG}; PI_{FC-BG} = LL_{FC} - PL_{BG}; and USCS = Unified Soil Classification System, as per BS 5930 [9].

4. Summary and Conclusions

In view of its apparent shortcomings, several attempts have been made to devise alternative testing approaches to the standard hand-rolling PL_{RT} method, targeting higher degrees of repeatability and reproducibility. Among these, device-rolling techniques, which mainly follow the same basic principles as the standard thread-rolling (by hand) test (i.e., PL_{RT}), have been highly underrated by some researchers and hence demand further attention. Furthermore, there seems to exist a general belief among them that the “PL” deduced from such devices, including the well-established PL_{BG} parameter obtained from the ASTM D4318/AASHTO T90 rolling device method, which is based on the original work by Bobrowski and Griekspoor [52], generally tends to greatly underestimate the PL_{RT}. To examine this point, and to better understand the true potentials and/or limitations of the BG-based device-rolling technique for soil plasticity determination, this study investigated the validity of the PL_{BG} parameter by quantifying and critically examining its statistical level of agreement with the standard PL_{RT}. The following conclusions can be drawn from this study:

- Following a comprehensive statistical analysis performed on a large and diverse database of 60 PL_{RT}–PL_{BG} test pairs, it was demonstrated that, under identical testing conditions, the BG-based and RT methods produce essentially similar PL values (i.e., PL_{RT} ≈ PL_{BG}). The 95% lower and upper agreement limits between PL_{BG} and

PL_{RT} were obtained as -5.03% and $+4.51\%$, respectively; implying that 95% of the differences between the two PL measurement methods lie between these two small water content limits, both of which can be deemed “statistically insignificant” when compared to the inductively-defined reference limit of $\pm 8\%$ (i.e., the highest possible difference/variation in the PL_{RT} based on its repeatability, as reported in the research literature).

- Further, the likelihoods of underestimating (i.e., $PL_{BG} < PL_{RT}$) and overestimating (i.e., $PL_{BG} > PL_{RT}$) the PL_{RT} were obtained as 50% and 40%, respectively; thereby, debunking the notion presented by some researchers that the BG method generally tends to greatly underestimate the PL_{RT} . It was also demonstrated that the degree of underestimation or overestimation does not systematically increase or decrease with changes in fundamental soil properties (i.e., plasticity level class, clay and silt contents, and soil mineralogy); suggesting that the differences between PL_{BG} and PL_{RT} are most likely random in nature.
- Finally, making use of the BS soil plasticity-chart framework, an attempt, for the first time, was made to examine the validity of the PL_{BG} parameter in the context of fine-grained soil classification. Compared to PL_{RT} , the likelihood of achieving consistent soil classifications employing the PL_{BG} (in conjunction with LL_{PC} and/or LL_{FC}) was shown to be 98%, with the classification discrepancies (only two cases out of 84 examined) being soil materials that plot relatively close to the A-Line. This implies that the PL_{BG} parameter, as determined using the ASTM D4318/AASHTO T90 rolling device method, can be used with confidence for routine soil classification purposes.

Author Contributions: Conceptualization, A.S. and B.C.O.; Methodology, A.S. and B.C.O.; Validation, A.S. and B.C.O.; Formal analysis, A.S.; Investigation, A.S. and B.C.O.; Writing—original draft preparation, A.S.; Writing—review and editing, A.S. and B.C.O.; Visualization, A.S.; Funding acquisition, A.S. All authors have read and agreed to the published version of the manuscript.

Funding: This research received no external funding.

Data Availability Statement: The authors declare that the data supporting the findings of this study are available within the article.

Conflicts of Interest: The authors declare no conflict of interest.

Abbreviations

AASHTO	American Association of State Highway and Transportation Officials
ASTM	American Society for Testing and Materials
BA	Bland–Altman (analysis/plot)
BG	Bobrowski and Griekspoor (method/device)
BS	British Standard
CE	Clay with extremely high plasticity
CH	Clay with high plasticity
CI	Clay with intermediate plasticity
CL	Clay with low plasticity
CV	Clay with very high plasticity
FC	Fall-cone (method)
ME	Silt with extremely high plasticity
MH	Silt with high plasticity
MI	Silt with intermediate plasticity
ML	Silt with low plasticity
MV	Silt with very high plasticity
PC	Percussion-cup (method)
RT	Rolling-thread (method)
USCS	Unified Soil Classification System

Notations

A_{FC}	Soil activity index ($=PI_{FC-RT}/f_{clay}$)
A_{PC}	Soil activity index ($=PI_{PC-RT}/f_{clay}$)
d	Cone penetration depth (FC test) [mm]
D_{BA}	Plastic limit difference, defined as $D_{BA} = PL_{BG} - PL_{RT}$ [%]
D_A	Actual vertical distance from the A-Line [%]
f_{clay}	Clay content [%]
f_{silt}	Silt content [%]
LAL	Lower (water content) agreement limit [%]
LB	Lower (PL_{BG} -to- PL_{RT} variation) boundary
LL_{FC}	Fall-cone liquid limit [%]
LL_{PC}	Percussion-cup liquid limit [%]
M_{BA}	Plastic limit average, defined as $M_{BA} = (PL_{BG} + PL_{RT})/2$ [%]
MAPE	Mean absolute percentage error [%]
n	Index of summation
N	Number of tests/observations
N_b	Number of blows (PC test)
NRMSE	Normalized root-mean-squared error [%]
PI_{FC-BG}	Plasticity index ($= LL_{FC} - PL_{BG}$) [%]
PI_{FC-RT}	Plasticity index ($= LL_{FC} - PL_{RT}$) [%]
PI_{PC-BG}	Plasticity index ($= LL_{PC} - PL_{BG}$) [%]
PI_{PC-RT}	Plasticity index ($= LL_{PC} - PL_{RT}$) [%]
PL_{BG}	Device-rolling plastic limit [%]
PL_{RT}	Thread-rolling (by hand) plastic limit [%]
$PL_{RT(max)}$	Maximum of PL_{RT} data [%]
$PL_{RT(min)}$	Minimum of PL_{RT} data [%]
R^2	Coefficient of determination
RMSE	Root-mean-squared error [% water content]
UAL	Upper (water content) agreement limit [%]
UB	Upper (PL_{BG} -to- PL_{RT} variation) boundary
w	Gravimetric water content [%]
μ_D	Arithmetic mean of D_{BA} ($=PL_{BG} - PL_{RT}$) data [%]
σ_D	Standard deviation of D_{BA} ($=PL_{BG} - PL_{RT}$) data [%]

References

- Atterberg, A. Lerornas förhållande till vatten, deras plasticitetsgränser och plasticitetsgrader. *K. Lantbr. Handl. Och Tidskr.* **1911**, *50*, 132–158. (In Swedish)
- Atterberg, A. Die plastizität der tone. *Int. Mitt. Der Bodenk.* **1911**, *1*, 4–37. (In German)
- Terzaghi, K. Simplified soil tests for subgrades and their physical significance. *Public Roads* **1926**, *7*, 153–170.
- Terzaghi, K. Principles of final soil classification. *Public Roads* **1926**, *8*, 41–53.
- Casagrande, A. Research on the Atterberg limits of soils. *Public Roads* **1932**, *13*, 121–136.
- Casagrande, A. Notes on the design of the liquid limit device. *Géotechnique* **1958**, *8*, 84–91. [[CrossRef](#)]
- AASHTO M145. *Standard Specification for Classification of Soils and Soil-Aggregate Mixtures for Highway Construction Purposes*; American Association of State Highway and Transportation Officials (AASHTO): Washington, DC, USA, 1995.
- ASTM D3282. *Standard Practice for Classification of Soils and Soil-Aggregate Mixtures for Highway Construction Purposes*; ASTM International: West Conshohocken, PA, USA, 2015. [[CrossRef](#)]
- BS 5930. *Code of Practice for Ground Investigations*; British Standards Institution (BSI): London, UK, 2015; ISBN 9780539081350.
- ASTM D2487. *Standard Practice for Classification of Soils for Engineering Purposes (Unified Soil Classification System)*; ASTM International: West Conshohocken, PA, USA, 2017. [[CrossRef](#)]
- Skempton, A.W.; Northey, R.D. The sensitivity of clays. *Géotechnique* **1952**, *3*, 30–53. [[CrossRef](#)]
- Seed, H.B.; Woodward, R.J.; Lundgren, R. Prediction of swelling potential for compacted clays. *J. Soil Mech. Found. Div.* **1962**, *88*, 53–87. [[CrossRef](#)]
- Nayak, N.V.; Christensen, R.W. Swelling characteristics of compacted, expansive soils. *Clays Clay Miner.* **1971**, *19*, 251–261. [[CrossRef](#)]
- Wroth, C.P.; Wood, D.M. Correlation of index properties with some basic engineering properties of soils. *Can. Geotech. J.* **1978**, *15*, 137–145. [[CrossRef](#)]
- Carrier, W.D. Consolidation parameters derived from index tests. *Géotechnique* **1985**, *35*, 211–213. [[CrossRef](#)]

16. Nakase, A.; Kamei, T.; Kusakabe, O. Constitutive parameters estimated by plasticity index. *J. Geotech. Eng.* **1988**, *114*, 844–858. [[CrossRef](#)]
17. Nagaraj, T.S.; Pandian, N.S.; Narashimha Raju, P.S.R. Stress state–permeability relationships for fine-grained soils. *Géotechnique* **1993**, *43*, 333–336. [[CrossRef](#)]
18. Gurtug, Y.; Sridharan, A. Compaction behaviour and prediction of its characteristics of fine grained soils with particular reference to compaction energy. *Soils Found.* **2004**, *44*, 27–36. [[CrossRef](#)]
19. Erzin, Y.; Erol, O. Swell pressure prediction by suction methods. *Eng. Geol.* **2007**, *92*, 133–145. [[CrossRef](#)]
20. Dolinar, B. Predicting the hydraulic conductivity of saturated clays using plasticity-value correlations. *Appl. Clay Sci.* **2009**, *45*, 90–94. [[CrossRef](#)]
21. Dolinar, B. Predicting the normalized, undrained shear strength of saturated fine-grained soils using plasticity-value correlations. *Appl. Clay Sci.* **2010**, *47*, 428–432. [[CrossRef](#)]
22. O’Kelly, B.C. Atterberg limits and remolded shear strength–water content relationships. *Geotech. Test. J.* **2013**, *36*, 939–947. [[CrossRef](#)]
23. Vardanega, P.J.; Haigh, S.K. The undrained strength–liquidity index relationship. *Can. Geotech. J.* **2014**, *51*, 1073–1086. [[CrossRef](#)]
24. Kootahi, K.; Mayne, P.W. Index test method for estimating the effective preconsolidation stress in clay deposits. *J. Geotech. Geoenviron. Eng.* **2016**, *142*, 04016049. [[CrossRef](#)]
25. Soltani, A.; Deng, A.; Taheri, A.; Sridharan, A. Consistency limits and compaction characteristics of clay soils containing rubber waste. *Proc. Inst. Civ. Eng. Geotech. Eng.* **2019**, *172*, 174–188. [[CrossRef](#)]
26. Wood, D.M. *Soil Behaviour and Critical State Soil Mechanics*, 1st ed.; Cambridge University Press: Cambridge, UK, 1991; ISBN 9780521337823.
27. Dolinar, B.; Trauner, L. Liquid limit and specific surface of clay particles. *Geotech. Test. J.* **2004**, *27*, 580–584. [[CrossRef](#)]
28. Trauner, L.; Dolinar, B.; Mišič, M. Relationship between the undrained shear strength, water content, and mineralogical properties of fine-grained soils. *Int. J. Geomech.* **2005**, *5*, 350–355. [[CrossRef](#)]
29. AASHTO T89. *Standard Method of Test. for Determining the Liquid Limit of Soils*; American Association of State Highway and Transportation Officials (AASHTO): Washington, DC, USA, 2013.
30. ASTM D4318. *Standard Test. Methods for Liquid Limit, Plastic Limit, and Plasticity Index of Soils*; ASTM International: West Conshohocken, PA, USA, 2017. [[CrossRef](#)]
31. BS 1377–2. *Methods of Test. for Soils for Civil. Engineering Purposes—Part. 2: Classification Tests*; British Standards Institution (BSI): London, UK, 1990; ISBN 0580178676.
32. BS EN 1997–2. *Eurocode 7—Geotechnical Design—Part. 2: Ground Investigation and Testing*; British Standards Institution (BSI): London, UK, 2007; ISBN 9780580718724.
33. AS 1289.3.9.1. *Methods of Testing Soils for Engineering Purposes: Soil Classification Tests—Determination of the Cone Liquid Limit of a Soil*; Standards Australia (SA): Sydney, Australia, 2015; ISBN 9781760352974.
34. O’Kelly, B.C.; Vardanega, P.J.; Haigh, S.K. Use of fall cones to determine Atterberg limits: A review. *Géotechnique* **2018**, *68*, 843–856. [[CrossRef](#)]
35. Wood, D.M.; Wroth, C.P. The use of the cone penetrometer to determine the plastic limit of soils. *Gr. Eng.* **1978**, *11*, 37.
36. Haigh, S.K.; Vardanega, P.J.; Bolton, M.D. The plastic limit of clays. *Géotechnique* **2013**, *63*, 435–440. [[CrossRef](#)]
37. AS 1289.3.2.1. *Methods of Testing Soils for Engineering Purposes: Soil Classification Tests—Determination of the Plastic Limit of a Soil—Standard Method*; Standards Australia (SA): Sydney, Australia, 2009; ISBN 0733790054.
38. AASHTO T90. *Standard Method of Test. for Determining the Plastic Limit and Plasticity Index of Soils*; American Association of State Highway and Transportation Officials (AASHTO): Washington, DC, USA, 2020.
39. Sherwood, P.T.; Ryley, M.D. An investigation of a cone-penetrometer method for the determination of the liquid limit. *Géotechnique* **1970**, *20*, 203–208. [[CrossRef](#)]
40. Belviso, R.; Ciampoli, S.; Cotecchia, V.; Federico, A. Use of cone penetrometer to determine consistency limits. *Gr. Eng.* **1985**, *18*, 21–22.
41. Sridharan, A.; Nagaraj, H.B.; Prakash, K. Determination of the plasticity index from flow index. *Geotech. Test. J.* **1999**, *22*, 175–181. [[CrossRef](#)]
42. Feng, T.W. Using a small ring and a fall-cone to determine the plastic limit. *J. Geotech. Geoenviron. Eng.* **2004**, *130*, 630–635. [[CrossRef](#)]
43. Sivakumar, V.; Glynn, D.; Cairns, P.; Black, J.A. A new method of measuring plastic limit of fine materials. *Géotechnique* **2009**, *59*, 813–823. [[CrossRef](#)]
44. Sivakumar, V.; O’Kelly, B.C.; Henderson, L.; Moorhead, C.; Chow, S.H. Measuring the plastic limit of fine soils: An experimental study. *Proc. Inst. Civ. Eng. Geotech. Eng.* **2015**, *168*, 53–64. [[CrossRef](#)]
45. Vardanega, P.J.; Haigh, S.K. Some recent developments in the determination of the Atterberg limits. In *Advances in Transportation Geotechnics and Materials for Sustainable Infrastructure (GSP 250)*; Bulut, R., Hsu, S.C., Eds.; American Society of Civil Engineers (ASCE): Reston, VA, USA, 2014; pp. 48–55. ISBN 9780784478509. [[CrossRef](#)]
46. O’Kelly, B.C. Reappraisal of soil extrusion for geomechanical characterisation. *Geotech. Res.* **2019**, *6*, 265–287. [[CrossRef](#)]
47. O’Kelly, B.C. Review of recent developments and understanding of Atterberg limits determinations. *Geotechnics* **2021**, *1*, 59–75. [[CrossRef](#)]

48. Prakash, K. Discussion of “Plastic limit, liquid limit, and undrained shear strength of soil—reappraisal” by Binu Sharma and Padma K. Bora. *J. Geotech. Geoenviron. Eng.* **2005**, *131*, 402. [[CrossRef](#)]
49. Nagaraj, H.B.; Sridharan, A.; Mallikarjuna, H.M. Re-examination of undrained strength at Atterberg limits water contents. *Geotech. Geol. Eng.* **2012**, *30*, 727–736. [[CrossRef](#)]
50. O’Kelly, B.C.; Vardanega, P.J.; Haigh, S.K.; Barnes, G.E. Discussion: Use of fall cones to determine Atterberg limits: A review. *Géotechnique* **2020**, *70*, 647–651. [[CrossRef](#)]
51. Gay, G.C.W.; Kaiser, W. Mechanization for remolding fine grained soils and for the plastic limit test. *J. Test. Eval.* **1973**, *1*, 317–318. [[CrossRef](#)]
52. Bobrowski, L.J.; Griekspoor, D.M. Determination of the plastic limit of a soil by means of a rolling device. *Geotech. Test. J.* **1992**, *15*, 284–287. [[CrossRef](#)]
53. Temyingyong, A.; Chantawarangul, K.; Sudasna-na-Ayudhya, P. Statistical analysis of influenced factors affecting the plastic limit of soils. *Kasetsart J. Nat. Sci.* **2002**, *36*, 98–102.
54. Barnes, G.E. An apparatus for the plastic limit and workability of soils. *Proc. Inst. Civ. Eng. Geotech. Eng.* **2009**, *162*, 175–185. [[CrossRef](#)]
55. Kayabali, K. Determination of consistency limits: A comparison between #40 and #200 materials. *Electron. J. Geotech. Eng.* **2011**, *16*, 1547–1561.
56. Kayabali, K. An alternative testing tool for plastic limit. *Electron. J. Geotech. Eng.* **2012**, *17*, 2107–2114.
57. Barnes, G.E. An apparatus for the determination of the workability and plastic limit of clays. *Appl. Clay Sci.* **2013**, *80–81*, 281–290. [[CrossRef](#)]
58. Barnes, G.E. The Plastic Limit and Workability of Soils. Ph.D. Thesis, The University of Manchester, Manchester, UK, 2013.
59. De Oliveira Modesto, C.; Bernardin, A.M. Determination of clay plasticity: Indentation method versus Pfefferkorn method. *Appl. Clay Sci.* **2008**, *40*, 15–19. [[CrossRef](#)]
60. Moreno-Maroto, J.M.; Alonso-Azcárate, J. An accurate, quick and simple method to determine the plastic limit and consistency changes in all types of clay and soil: The thread-bending test. *Appl. Clay Sci.* **2015**, *114*, 497–508. [[CrossRef](#)]
61. Moreno-Maroto, J.M.; Alonso-Azcárate, J. A bending test for determining the Atterberg plastic limit in soils. *J. Vis. Exp.* **2016**, *112*, e54118. [[CrossRef](#)]
62. Moreno-Maroto, J.M.; Alonso-Azcárate, J. Plastic limit and other consistency parameters by a bending method and interpretation of plasticity classification in soils. *Geotech. Test. J.* **2017**, *40*, 467–482. [[CrossRef](#)]
63. Rashid, A.S.A.; Kassim, K.A.; Katimon, A.; Noor, N.M. Determination of plastic limit of soil using modified methods. *Malays. J. Civ. Eng.* **2008**, *20*, 295–305. [[CrossRef](#)]
64. Ishaque, F.; Hoque, M.N.; Rashid, M.A. Determination of plastic limit of some selected soils using rolling device. *Progress. Agric.* **2013**, *21*, 187–194. [[CrossRef](#)]
65. Rehman, H.U.; Pouladi, N.; Pulido-Moncada, M.; Arthur, E. Repeatability and agreement between methods for determining the Atterberg limits of fine-grained soils. *Soil Sci. Soc. Am. J.* **2020**, *84*, 21–30. [[CrossRef](#)]
66. Casagrande, A. Classification and identification of soils. *Proc. Am. Soc. Civ. Eng.* **1947**, *73*, 783–810.
67. Soltani, A.; O’Kelly, B.C. Discussion of “The flow index of clays and its relationship with some basic geotechnical properties” by G. Spagnoli, M. Feinendegen, L. Di Matteo, and D. A. Rubinos, published in Geotechnical Testing Journal 42, No. 6 (2019): 1685–1700. *Geotech. Test. J.* **2021**, *44*, 216–219. [[CrossRef](#)]
68. Soltani, A.; Deng, A.; Taheri, A.; Sridharan, A.; Estabragh, A.R. A framework for interpretation of the compressibility behavior of soils. *Geotech. Test. J.* **2018**, *41*. [[CrossRef](#)]
69. Bland, J.M.; Altman, D.G. Measuring agreement in method comparison studies. *Stat. Methods Med. Res.* **1999**, *8*, 135–160. [[CrossRef](#)] [[PubMed](#)]