



Minerva Access is the Institutional Repository of The University of Melbourne

Author/s:

Zaccarian, L;Nesic, D;Teel, AR

Title:

L-2 anti-windup for linear dead-time systems

Date:

2005-12-01

Citation:

Zaccarian, L., Nesic, D. & Teel, A. R. (2005). L-2 anti-windup for linear dead-time systems. *SYSTEMS & CONTROL LETTERS*, 54 (12), pp.1205-1217. <https://doi.org/10.1016/j.sysconle.2005.04.009>.

Persistent Link:

<https://hdl.handle.net/11343/299512>

\mathcal{L}_2 anti-windup for linear dead-time systems

Luca Zaccarian[‡]

Dip. di Informatica, Sistemi e
Produzione
Univ. of Rome, Tor Vergata
00133 Rome, Italy
zack@disp.uniroma2.it

Dragan Nešić*

Department of Electrical and
Electronic Engineering
The University of Melbourne
Parkville, 3010, Victoria, Australia
d.nesic@ee.mu.oz.au

Andrew R. Teel[†]

Department of Electrical and
Computer Engineering
University of California
Santa Barbara, CA 93106
teel@ece.ucsb.edu

Abstract

In this paper we address and solve the problem of anti-windup augmentation for linear systems with input and output delay. In particular, we give a formal definition of an optimal \mathcal{L}_2 gain based anti-windup design problem in the global, local, robust and nominal cases. For each of these cases we show that a specific anti-windup compensation structure (which is a generalization of the approach in [29]) is capable of solving the anti-windup problem whenever this is solvable. The effectiveness of the proposed scheme is shown on a simple example taken from the literature, in which the plant is a marginally stable linear system.

1 Introduction

1.1 Input saturation and anti-windup

As the research activity in automatic control progresses, several mathematical tools and nonlinear control ideas become increasingly applicable to practical control problems. One such area deals with the so-called “anti-windup” strategy, where significant progress has been made over the past decade. Anti-windup denotes the design of a compensator which “augments” an existing controller on a plant subject to input saturation. In particular, in the anti-windup problem statement it is assumed that a controller has already been designed disregarding the saturation effect, so that the corresponding closed-loop behaves very desirably for small enough signals. The goal of anti-windup is then to recover as much as possible that “unconstrained” performance (and, at the very least, stability) also for large signals, for which the saturation nonlinearity operates in its nonlinear region.

The anti-windup design problem has been qualitatively stated already from the 1950’s both in the analog [14] and in the digital control framework [6]. However, the arising solutions were at that time mainly application oriented and not applicable to large classes of control systems. It was only in the 1980’s that some design techniques applicable to large classes of control systems were formalized (see, *e.g.*, [10, 1, 20]), although the issue of performance characterization and improvement was still mostly unsolved. Interesting surveys of these techniques can be found in [9, 11]. In the past decade, a great deal of attention has been devoted to the formalization and solution of the anti-windup problem using modern control theory techniques and several recent papers have characterized thoroughly the linear anti-windup design technique for linear systems (see [21, 7]). Moreover, several nonlinear solutions have been given to the nonlinear anti-windup design problem for linear plants (see, *e.g.*, [29, 30, 2]) and to the nonlinear anti-windup problem for nonlinear plants (see, *e.g.*, [18, 19]).

*Research supported by the Australian Research Council under the large grants scheme.

[†]Research supported in part by AFOSR grant number F49620-03-1-0203 and NSF grant number ECS-0324679.

[‡]Research supported in part by ASI and MIUR through PRIN project MATRICES and FIRB project TIGER.

1.2 Anti-windup for dead-time systems

While, on one hand, actuator saturation is a ubiquitous phenomenon which makes anti-windup useful in any control system where a sufficiently high accuracy is needed (this typically happens in aggressive high-performance designs), one other phenomenon that is often found in conjunction with saturation is the presence of time delays at the input and at the output of the plant. Similar to the saturation effect, the delay phenomenon becomes crucial when the control task is aggressive enough so that the phase roll-off may destroy the stability (and/or performance) properties of the closed-loop system. For these saturated and retarded systems, it is of interest to address the corresponding generalization of the anti-windup problem. This can be intuitively seen as follows: assume that a *predesigned* controller (possibly including internal delays) is available for the delayed plant without input saturation; then build an anti-windup compensator that, when interconnected to the existing control system is capable of

1. reproducing the responses induced by that predesigned controller when signals are small enough not to activate actuator saturation;
2. recovering the stability (and, partially, the performance) that would be otherwise lost due to the nonlinear effects of saturation, for all other signals.

The solution to this anti-windup problem is appealing because it makes it possible to implement control laws for delayed systems *without* saturation also on saturated and delayed plants. Many such tools are available in the literature. See, *e.g.*, the many generalizations of the Smith predictor structure, first proposed in [25].

Note that the anti-windup problem described above is different from the problem of bounded stabilization of input delayed systems, where significant amount of work has been done, especially in recent years. (See, for example the preliminary work in [24] and also recent contributions in [12, 13, 5, 16, 27].) Although interesting on their own sake, bounded stabilizers for input delayed systems are not sufficient to solve the anti-windup problem addressed here because they don't necessarily fulfill the requirement (at item 1 above) that the closed-loop system behaves locally as required by the *given* unconstrained controller, which is part of the problem specification, rather than a degree of freedom in the design.

When focusing on the anti-windup design problem for dead-time systems, a very natural solution can be obtained by suitably generalizing (in a straightforward way) the classical Internal Model Control (IMC) technique for anti-windup [32], where the stability problem is fully solved for the case where the open-loop plant is characterized by a Hurwitz matrix. However, it is known that IMC-based anti-windup designs may lead to poor performance, which leaves space for significant improvement over this straightforward construction. Anti-windup design for linear dead-time control systems was also addressed in [22], where a solution to the problem is given, once again for the case where the open-loop plant is characterized by a Hurwitz matrix and also under some additional technical assumptions. Despite the work of [22] and the IMC extension mentioned above, very little has been done so far on anti-windup design for dead-time linear control systems. Nevertheless, these ideas have been proven to be successful on several applications, including active queue management in TCP networks [23] and other experiments discussed in [4]. It is also notable the work in [27], where a static anti-windup gain is included within a saturated control design task for a dead-time plant. In [27], the anti-windup goal is not directly addressed because the controller is not considered as a design constraint but rather as a degree of freedom within the control system design. Nevertheless, that underlying technique could be easily generalized for static anti-windup design whenever the unconstrained controller is a linear system without delays.

1.3 Contribution

In this paper, we address the anti-windup design problem for dead-time control systems. The proposed solution is applicable to any linear control system, including the case where the unconstrained controller contains internal time delays (such as in the case where it arises from a Smith predictor design). Moreover, a global solution is given to the problem under the (necessary) property that the plant state matrix has eigenvalues with non positive real part, thus extending previous results to the case of poles on the imaginary axis. As compared to the solution in [22], the approach proposed here is stronger because it holds under weaker conditions (these conditions are actually shown to be necessary for the solvability of the problem). Moreover, whenever the approach in [22] is applicable, it can be interpreted as a special selection among a

family of solutions parametrized within the framework proposed here. As compared to the potential static anti-windup solution residing in the approach of [27], note that our result provides a general solution to the problem, whereas the results in [27] are only applicable if certain matrix inequalities are satisfied.

The paper is organized as follows. We first formalize the anti-windup design goal (which is based on a generalization of the delay-free ideas in [29]) introducing the global, local, robust and nominal problem statements in Section 2. Then in Section 3 we prove necessary and sufficient conditions for the solvability of the problem and provide a general framework for the corresponding solution (whenever it exists). In this framework, specific selections of a stabilizing signal are shown to solve the different instances of the anti-windup problem. In Section 4 we apply our design to an example where the plant state matrix is non Hurwitz (so that previous techniques are not applicable) and show the desirable performance induced by the proposed anti-windup strategy.

1.4 Notation

The following definitions will be useful to clarify the notation used throughout the paper.

- Given a vector $w \in \mathbb{R}^n$ and a set $\mathcal{S} \subset \mathbb{R}^n$, the distance of the vector w from the set \mathcal{S} is defined as

$$\text{dist}(w, \mathcal{S}) := \inf_{s \in \mathcal{S}} |w - s|.$$

- Given numbers $\underline{a} \leq a \leq b \leq \bar{b}$ and a function $w : [\underline{a}, \bar{b}] \rightarrow \mathbb{R}^n$, the \mathcal{L}_2 norm of $w(\cdot)$ restricted to the interval $[a, b]$ is defined as

$$\|w_{[a,b]}\|_2 := \sqrt{\int_a^b |w(\tau)|^2 d\tau}.$$

If $[\underline{a}, \bar{b}] = [0, \infty)$, to simplify notation we will often use $\|w\|_2$ in place of $\|w_{[0,\infty)}\|_2$. We will denote $\|w_{[0,\infty)}\|_2$ as the \mathcal{L}_2 norm of $w(\cdot)$ and, if $\|w_{[0,\infty)}\|_2 < \infty$, we will say that $w(\cdot) \in \mathcal{L}_2$.

- Given a constant $t_d > 0$ and a function $s : [-t_d, \infty) \rightarrow \mathbb{R}^n$, then for all $t \geq 0$, the functional $s_d(\cdot)$ is defined as $s_d(t) := \{s(\tau), \tau \in [t - t_d, t]\}$. Moreover, for each $t \geq 0$, the norm $|s_d(t)|$ is defined as $|s_d(t)| := \max_{\tau \in [t-t_d, t]} |s(\tau)|$.
- Let $K > 0$ and $\gamma > 0$ be given. A nonlinear functional differential equation of the form

$$\begin{aligned} \dot{x} &= f(x_d(t), w_d(t)) \\ y &= g(x_d(t), w_d(t)) \end{aligned}$$

is finite gain \mathcal{L}_2 stable from w to y if for all functions $w(\cdot)$ and initial conditions $x_d(0)$, the following bound holds for all $t \geq 0$

$$\|y_{[0,t]}\|_2 \leq K|x_d(0)| + \gamma\|w_{[-t_d,t]}\|_2.$$

2 Problem statement

Consider a linear time-invariant plant subject to input and output delays:

$$\begin{aligned} \dot{x}(t) &= Ax(t) + B\text{sat}(u(t - \tau_I)) + B_d d(t) + \psi_x(t) \\ y(t) &= Cx(t - \tau_O) + D\text{sat}(u(t - \tau_I - \tau_O)) + D_d d(t - \tau_O) + \psi_y(t) \\ z(t) &= C_z x(t) + D_z \text{sat}(u(t - \tau_I)) + \psi_z(t) \end{aligned} \tag{1}$$

where $\tau_I > 0$ is a uniform delay at the plant control input $u \in \mathbb{R}^m$, $\tau_O > 0$ is a uniform delay¹ at the plant output measurement $y \in \mathbb{R}^p$, z represents the performance output (without loss of generality we can assume that this output is not delayed) and d represents a disturbance input. The three extra signals ψ_x, ψ_y, ψ_z can

¹Note that, by the uniformity property, the two delays at the plant input and output can be lumped in a single time delay, either at the input or at the output of the plant, therefore slightly reducing the notation in this paper. We use however this type of notation here to parallel the notation first used in [22] and to compare our results to those therein reported.

be stacked in a single vector Ψ representing the output of the following linear system (represented in the Laplace domain)

$$\Psi(s) := \begin{bmatrix} \psi_x(s) \\ \psi_y(s) \\ \psi_z(s) \end{bmatrix} := \Delta(s) \begin{bmatrix} x(s) \\ u(s) \\ d(s) \end{bmatrix} = \begin{bmatrix} \Delta_{xx}(s) & \Delta_{ux}(s) & \Delta_{dx}(s) \\ \Delta_{xy}(s) & \Delta_{uy}(s) & \Delta_{dy}(s) \\ \Delta_{xz}(s) & \Delta_{uz}(s) & \Delta_{dz}(s) \end{bmatrix} \begin{bmatrix} x(s) \\ u(s) \\ d(s) \end{bmatrix} \quad (2)$$

which may be infinite dimensional (it may have internal delays) and represents unmodeled dynamics and/or parameter uncertainties in the model (1). The system corresponding to the perturbed plant (1), (2) is represented by the dashed box in Figure 1. We will need the following assumption for the system (1), (2).

Assumption 1 *The pair (C_z, A) is detectable.² The system (2) is finite-gain input/output \mathcal{L}_2 stable from $(x(\cdot), u(\cdot), d(\cdot))$ to $\Psi(\cdot)$ with \mathcal{L}_2 gain equal to γ_Δ .*

Assume that a linear controller (defined, in general, by linear functional differential equations) has been designed for the following linear dead-time system *without* input saturation

$$\begin{aligned} \dot{x}(t) &= Ax(t) + Bu(t - \tau_I) + B_d d(t) + \psi_x(t) \\ y(t) &= Cx(t - \tau_O) + Du(t - \tau_I - \tau_O) + D_d d(t - \tau_O) + \psi_y(t) \\ z(t) &= C_z x(t) + D_z u(t - \tau_I) + D_{dz} d(t) + \psi_z(t) \end{aligned} \quad (3)$$

and that the controller equations can be written as

$$\begin{aligned} \dot{x}_c(t) &= f(x_{c,d}(t), u_{c,d}(t), r_d(t)) \\ y_c(t) &= g(x_{c,d}(t), u_{c,d}(t), r_d(t)), \end{aligned} \quad (4)$$

where $f(\cdot, \cdot, \cdot)$ and $g(\cdot, \cdot, \cdot)$ are linear functionals.³ In particular, the controller (4) is assumed to enforce a desirable closed-loop behavior on the unconstrained plant (3) when interconnected through the following unconstrained interconnection equations

$$u(t) = y_c(t), \quad u_c(t) = y(t). \quad (5)$$

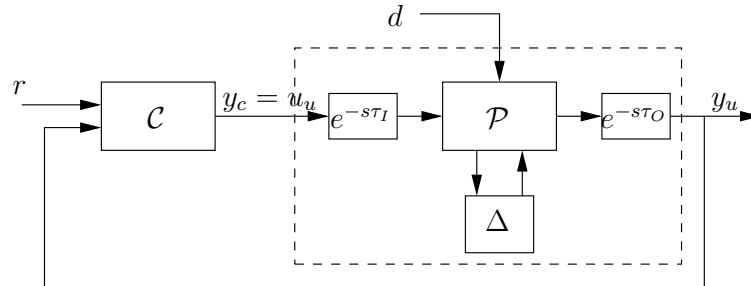

Figure 1: The unconstrained closed-loop system.

The corresponding closed-loop system (3), (4), (5) is represented in Figure 1 and will be referred to as the *unconstrained closed-loop system* henceforth. Moreover, its response will be called *unconstrained response*. The following assumption will hold for the unconstrained closed-loop.

Assumption 2 *There exists a small enough gain $\gamma_\Delta > 0$ such that the unconstrained closed-loop system (3), (2), (4), (5) is well-posed (namely, unique solutions exist for all initial states and for all inputs) and finite-gain \mathcal{L}_2 stable from the input $\Psi = (\psi_x, \psi_y, \psi_z)$ to the closed-loop state and output, uniformly over all selections of the system (2) satisfying Assumption 1.*

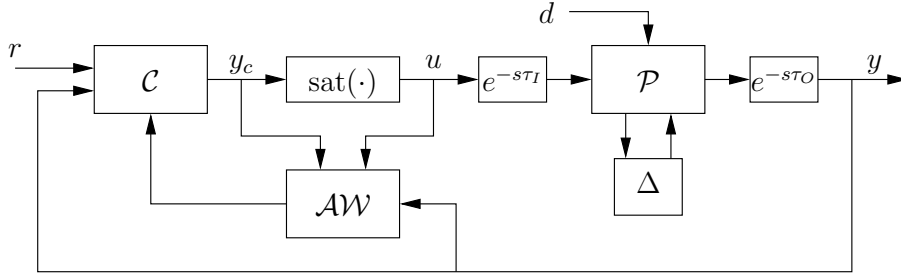

Figure 2: The anti-windup closed-loop system.

We will address in this paper the anti-windup problem arising when saturation is present at the plant input, so that the unconstrained performance of the closed-loop (3), (2), (4), (5) is only feasible for small enough signals. For simplicity, we will consider decentralized saturation functions, although the results can be extended in a straightforward way to the more general class of nonlinearities characterized in [29, Assumption 2]. Similar to the approach in [29], to properly formalize the anti-windup problem, we need to introduce a subset \mathcal{U} of the plant input vector space \mathbb{R}^m , which is a strict subset of the linear region of the saturation function, namely

$$\exists \delta > 0, \text{ s.t. } u + \delta \frac{v}{|v|} \in \{w \in \mathbb{R}^m : w = \text{sat}(w)\}, \quad \forall u \in \mathcal{U}, v \in \mathbb{R}^m. \quad (6)$$

Based on this set \mathcal{U} and following the anti-windup approach for undelayed linear plants, the main anti-windup goal will address the design of the *anti-windup compensator* \mathcal{AW} of Figure 2 with the goal of recovering as much as possible the “response without saturation” (herein called unconstrained response) on the saturated (and compensated) closed-loop of Figure 2 (this will be called *anti-windup closed-loop system* henceforth). In the following, for any selection of the external signals $r(\cdot)$, $d(\cdot)$, given initial conditions for the plant (3) and for the controller (4), we will denote the unconstrained closed-loop response using overlines. Moreover, given the same initial conditions for the saturated plant (1) and the controller (4), we will denote the corresponding anti-windup closed-loop response without overlines.

Definition 1 Given a plant (1) and a controller (4) satisfying Assumption 2, and a set $\mathcal{U} \in \mathbb{R}^m$ satisfying (6), an anti-windup compensator \mathcal{AW} solves the corresponding

- *robust global anti-windup problem* if there exists a continuous positive nondecreasing function $\bar{\gamma} : \mathbb{R}_{\geq 0} \rightarrow \mathbb{R}_{\geq 0}$ and a (sufficiently small) \mathcal{L}_2 gain γ_Δ for the unmodeled dynamics (2) such that for all initial conditions and all external inputs,⁴

$$\|z - \bar{z}\|_2 \leq \bar{\gamma}(\|\text{sat}(\bar{u}) - \bar{u}\|_2); \quad (7)$$

- *nominal global anti-windup problem* if the bound (7) holds with $\Psi \equiv 0$ (namely, in the absence of unmodeled dynamics);
- *robust local anti-windup problem* if the bound (7) holds for small enough values of the initial conditions of the anti-windup filter \mathcal{AW} and of $\|\text{sat}(\bar{u}) - \bar{u}\|_2$.

◻

²This assumption is only needed to prove the necessity of the results of Theorem 1. The sufficiency statements still hold when (C_z, A) is not detectable.

³As defined in the notation Section 1.4, the subscripts d denote the dependence of the functional on the past history of the signal under consideration.

⁴For simplicity of notation, in equation (7) and throughout the proof of the paper, the \mathcal{L}_2 bounds are all given omitting the initial conditions.

Remark 1 Note that (7) enforces a bound on the output mismatch $(z - \bar{z})(\cdot)$ based on the energy spent by the (ideal) unconstrained input response outside the saturation limits. This characterization is reasonable because that input energy cannot be instantly recovered on the saturated control system, regardless of what the anti-windup compensation is. Therefore, (7) successfully captures the intuitive performance recovery goals of the anti-windup design. Note also that (7) implicitly enforces the property that all the unconstrained trajectories that never exceed the saturation limits (so that $\|\text{sat}(\bar{u}) - \bar{u}\|_2 = 0$), will be exactly reproduced by the anti-windup closed-loop system. Indeed, in that case, (7) implies that $\|z - \bar{z}\|_2 = 0$, namely $z(\cdot) \equiv \bar{z}(\cdot)$. \circ

3 Main result

In this section we will address the anti-windup problem of Definition 1 and give necessary and sufficient conditions for its solvability, together with a constructive solution whenever the problem is solvable. For the solution of this problem, we will select the filter \mathcal{AW} as the following dynamical system:

$$\begin{aligned} \dot{x}_{aw}(t) &= Ax_{aw}(t) + B(\text{sat}(u(t)) - y_c(t)) \\ v_1(t) &= f_{aw}(x_{aw}(t), \text{sat}(u(t)) - y_c(t)) \\ v_2(t) &= Cx_{aw}(t - \tau_I - \tau_O) + D(\text{sat}(u(t - \tau_I - \tau_O)) - y_c(t - \tau_I - \tau_O)), \end{aligned} \quad (8)$$

where the selection of the function $f_{aw}(\cdot, \cdot)$ will be specified later. This filter will modify the interconnection between the plant (1) and the controller (4) through the following equations

$$u(t) = y_c(t) + v_1(t), \quad u_c(t) = y(t) - v_2(t). \quad (9)$$

The corresponding closed-loop system is represented in Figure 3.

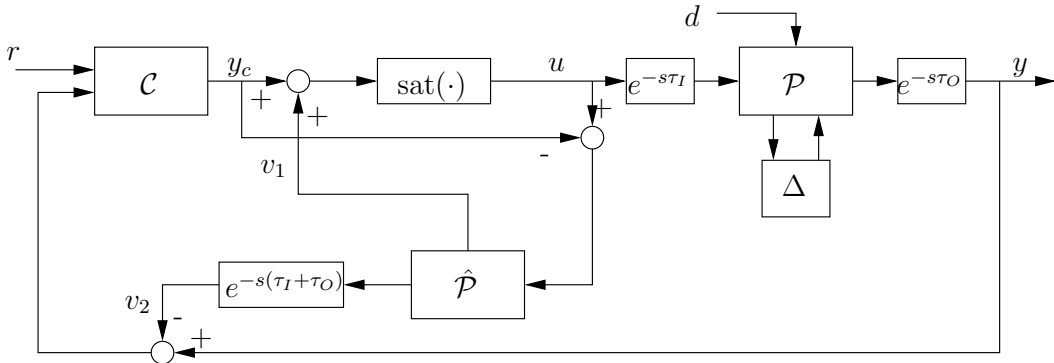

Figure 3: The proposed anti-windup scheme.

The effectiveness of the structure (8), (9) of the anti-windup compensator in solving the anti-windup problem of Definition 1 is based on the fact that (at least in the case where $\Psi \equiv 0$) the arising closed-loop system can be transformed into the cascade interconnection between the functional differential equation corresponding to the unconstrained closed-loop (3), (4), (5) and an extra subsystem consisting of the filter (8) which needs to be stabilized by suitably designing the compensation signal v_1 in (9). This scheme arises from a generalization of the scheme adopted in [29] for anti-windup design for linear undelayed systems. Indeed, the same tools introduced in [29] for the design of the signal v_1 can be also used in the framework (8), (9). To this aim, we report in the following the result in [29, Lemma 1], which will be useful next. As reported in [29], this lemma can be proven by combining the results in [17] and [28].

Lemma 1 *For the control system*

$$\dot{x}_{aw} = Ax_{aw} + B(\text{sat}(v + \varphi(t)) - \varphi(t)),$$

where (A, B) is stabilizable, and U satisfies (6),

1. there always exists a globally Lipschitz feedback $v = k(x_{aw})$ such that if $\|\text{dist}(\varphi, \mathcal{U})\|_2$ and $|x_{aw}(0)|$ are sufficiently small, then $x_{aw}(\cdot) \in \mathcal{L}_2$ and the \mathcal{L}_2 gain from $\text{dist}(\varphi(\cdot), \mathcal{U})$ to $x_{aw}(\cdot)$ is finite;
2. if all the eigenvalues of A have non-positive real part, then there exists a globally Lipschitz feedback $v = k(x_{aw})$ such that if $\text{dist}(\varphi(\cdot), \mathcal{U}) \in \mathcal{L}_2$, then $x_{aw}(\cdot) \in \mathcal{L}_2$; moreover, if A is critically stable, i.e., if there exists $P = P^T > 0$ such that $A^T P + PA \leq 0$, then the function $k(\cdot)$ can be taken to be the linear function $x_{aw} \mapsto k(x_{aw}) := -B^T P x_{aw}$. Finally, when A is Hurwitz, the \mathcal{L}_2 gain from $\text{dist}(\varphi(\cdot), \mathcal{U})$ to $x_{aw}(\cdot)$ is finite.

We are now ready to state our main result.

Theorem 1 *Suppose Assumptions 1 and 2 hold for the plant (1), (2) and for the controller (4). Then, according to Definition 1, the following holds*

1. the local robust anti-windup problem is always solvable;
2. the global nominal anti-windup problem is solvable if and only if A has poles in the closed left half plane;
3. the global robust anti-windup problem is solvable if and only if A is Hurwitz;
4. whenever any of the anti-windup problems is solvable, the anti-windup filter (8) with the interconnection equations (9) and with the selection $f_{aw}(x_{aw}, \text{sat}(u) - y_c) = k(x_{aw})$ according to the constructive result of Lemma 1, is well-posed and is a solution to the problem.

Proof. *Necessity.* The necessity in item 2 can be proved by contraposition. Indeed, if A has poles in the open right hand plane, the open-loop system is exponentially unstable. Well known results (see, e.g., [26]) state that saturated exponentially unstable plants are not globally null controllable, hence there exist large enough initial conditions for the plant such that the response with saturation will diverge regardless of the anti-windup action. Consequently, since by Assumption 2 the unconstrained response will always be bounded, by the detectability property of Assumption 1, the bound (7) will not hold.

The necessity in item 3 follows by selecting $\Delta_{xx}(s) = \gamma_\Delta I$ and all the other entries of the matrix transfer function in (2) equal to zero, where $\gamma_\Delta > 0$ is arbitrarily small. Then, the state matrix of the perturbed system will be $A + \gamma_\Delta I$, with $\gamma_\Delta > 0$. Therefore, if A is not Hurwitz, this new state matrix will have poles in the open right hand plane (regardless of how small the gain γ_Δ is). Finally, the proof of the necessity can be completed similarly to the case at item 2 proven above.

Sufficiency. The proof of the sufficiency is constructive and is based on the structure (8), (9) with $f_{aw}(\cdot, \cdot)$ selected as $f_{aw}(x_{aw}, \text{sat}(u) - y_c) = k(x_{aw})$ according to Lemma 1. Due to space constraints, we will only address here the case where the unmodeled dynamics (2) are absent (namely, $\Psi \equiv 0$). The proof extends to the robust case by small gain arguments similar to those carried out in [29].

Consider the anti-windup closed-loop (1), (4), (8), (9), write the closed-loop dynamics in the coordinates $(e(t), x_c(t), x_{aw}(t)) = (x(t) - x_{aw}(t - \tau_I), x_c(t), x_{aw}(t))$ as follows (here, $y_e(t) = y(t) - v_2(t)$; moreover, z_e and z_{aw} are new outputs of the closed-loop system):

$$\begin{cases} \dot{e}(t) &= A e(t) + B y_c(t - \tau_I) + B_d d(t) \\ y_e(t) &= C e(t - \tau_O) + D y_c(t - \tau_I - \tau_O) + D_d d(t - \tau_O) \\ z_e(t) &= C_z e(t) + D_z y_c(t - \tau_I) + D_{dz} d(t) \\ \dot{x}_c(t) &= f(x_{c,d}(t), y_{e,d}(t), r_d(t)) \\ y_c(t) &= g(x_{c,d}(t), y_{e,d}(t), r_d(t)) \end{cases} \quad (10a)$$

$$\begin{cases} \dot{x}_{aw}(t) &= A x_{aw}(t) + B \left(\text{sat}(u(t)) - y_c(t) \right) \\ v_1(t) &= K x_{aw}(t) + L \left(\text{sat}(u(t)) - y_c(t) \right) \\ z_{aw}(t) &= C_z x_{aw}(t) + D_z \left(\text{sat}(u(t)) - y_c(t) \right) \\ u(t) &= y_c(t) + v_1(t). \end{cases} \quad (10b)$$

It is evident that the closed-loop (10) is a cascade interconnection of two subsystems, where (10a) coincides exactly with the unconstrained closed-loop system (3), (4), (5). Therefore, if the initial condition of (8) is $x_{aw,d}(0) = 0$, then ⁵

$$y_c(t) = \bar{u}(t), \forall t \geq 0. \quad (11)$$

Moreover, the additional output z_e of (10a) satisfies $z_e(t) = \bar{z}(t)$ for all times. Consider now the additional output z_{aw} of the second subsystem (10b) and notice that, since by definition $e(t) = x(t) - x_{aw}(t - \tau_I)$, then $z_e(t) = z(t) - z_{aw}(t - \tau_I)$ for all times. Therefore,

$$z(t) - \bar{z}(t) = z_{aw}(t - \tau_I), \quad \forall t \geq \tau_I, \quad (12)$$

and consequently, ⁶

$$\|(z - \bar{z})\|_2 = \|z_{aw}\|_2. \quad (13)$$

Since $u(t) = y_c(t) + k(x_{aw}(t))$, by the global Lipschitz property of the saturation function, we have for all $t \geq 0$,

$$|\text{sat}(u(t)) - y_c(t)| \leq |k(x_{aw}(t))| + |\text{sat}(y_c(t)) - y_c(t)|.$$

Therefore, since by Lemma 1 $k(\cdot)$ is globally Lipschitz, substituting the previous bound in the third equation of (10b), it follows that there exists $\gamma > 0$ such that for all $t \geq 0$

$$|\text{sat}(u(t)) - y_c(t)| \leq \gamma(|x_{aw}(t)| + |\text{sat}(y_c(t)) - y_c(t)|). \quad (14)$$

Finally, the proof of the theorem is completed by applying Lemma 1 with $\varphi(\cdot) \equiv y_c(\cdot)$ and combining the resulting \mathcal{L}_2 bound with equations (11), (13) and (14). •

Remark 2 The selection for v_1 proposed in Lemma 1 is sufficient to solve the anti-windup problems of Definition 1. However, from a performance perspective, alternative selections may be more desirable because they improve the unconstrained response recovery transient. To this aim, a useful property arising from the structure (8), (9) is that as shown in the proof of Theorem 1 (see equation (12)), regardless of the selection of v_1 , the mismatch between the unconstrained and the actual performance response is given by the extra output z_{aw} in (10b). Therefore, v_1 can be selected by only focusing on the stabilization of the (undelayed!) subsystem (10b) and on the performance seen at this particular output z_{aw} .

In the past years, several techniques have been proposed in the context of the undelayed anti-windup problem to improve the corresponding transient responses. Most of these results correspond to linear matrix inequality (LMI) formulations of convex optimization problems. Fortunately, the same approaches can be applied also to the time delayed problem addressed here because of the cascade structure (10) induced by the filter (8). Among these techniques, nonlinear scheduled techniques were proposed in [30] and sampled-data techniques were proposed in [2]. Moreover, in [31] the selection of the function $f_{aw}(\cdot, \cdot)$ is optimized among the family of linear functions:

$$f_{aw}(x_{aw}, \text{sat}(u) - y_c) = Kx_{aw} + L(\text{sat}(u) - y_c), \quad (15)$$

where the gains K and L arise from suitable LMIs easily solvable by convex optimization. The difference between (15) and the selection proposed in Lemma 1 (at least for the Hurwitz case) is in the presence of the feedthrough term L , which evidently enforces an algebraic loop around the saturation. It is commonly acknowledged (see, *e.g.*, [21]) that this algebraic loop may significantly improve the transient performance of the control system, especially in the MIMO case. Although the LMI-based selection of K and L proposed in [31] guarantees that the interconnection is well-posed, the corresponding optimal solution might often lead

⁵In the case when $x_{aw,d}(0) \neq 0$ there will be an additional term depending on the initial condition in the \mathcal{L}_2 bound (7). To keep the discussion simple, we are omitting the initial conditions in the \mathcal{L}_2 bounds of this paper (the corresponding relations are a straightforward generalization of the initial condition-free ones).

⁶Note that due to the presence of the input delay, since the plant initial conditions are assumed to be the same in the unconstrained and in the anti-windup case, then $z(t) - \bar{z}(t) = 0$ for all $t \in [0, \tau_I]$.

to values of L that are very close to a non well-posed interconnection. In those cases it is useful to augment the LMIs of [31] with an extra matrix inequality of the form

$$\begin{bmatrix} 2(\rho - 1)W - \rho X_2 - \rho X_2^T & \rho X_2^T \\ \rho X_2 & \frac{\eta - \rho}{2}W \end{bmatrix} > 0, \quad (16)$$

where $\rho \in (0, 1)$ and $\eta > \rho$. Based on the results of [8], this bound will ensure that the explicit solution to the implicit equation imposed by the algebraic loop in (8) is Lipschitz of level $\eta \sqrt{\frac{\sigma_M(W)}{\sigma_m(W)}}$ (where $\sigma_M(\cdot)$, $\sigma_m(\cdot)$ denote the maximum and minimum singular value of the matrix at argument, respectively), thereby not allowing the arising anti-windup solution to be ill-posed. \circ

Remark 3 The approach given here can be easily seen as a generalization of the construction in [22]. This generalization allows to remove the technical Assumption (A3) in [22] (thus solving the anti-windup problem also when this Assumption (A3) doesn't hold), it allows to establish stability of the arising closed-loop whenever the plant is Hurwitz and it allows, in general, to guarantee improved performance by way of the degrees of freedom in the selection of v_1 .

Indeed, by suitable loop transformations and some tedious calculations, it can be shown that the anti-windup solution proposed in [22] for dead-time plants is equivalent to using the filter (8) with the selection

$$v_1(s) = -D_c(s)v_2(s), \quad (17)$$

where the matrix $D_c(s)$ corresponds to the input-output link of the unconstrained controller. In particular, in [22, §3], the unconstrained controller is a delay-free LTI system and $D_c(s) = L$ is its (constant) input-output matrix; in [22, §4], the unconstrained controller has a specific structure with an internal time delay τ_3 and $D_c(s) = L_3 L_1 (I - e^{-s\tau_3} L_2 L_1)^{-1}$ is the corresponding term ⁷ related to the generalized input-output link (see [22] for details).

This re-interpretation of the scheme of [22] actually clarifies the technical Assumption (A3) therein reported, which corresponds to requiring that the matrix $S = A - e^{-s(\tau_I + \tau_O)} B (I + e^{-s(\tau_I + \tau_O)} D_c(s) D)^{-1} D_c(s) C$ has stable eigenvalues. Indeed, since the unconstrained closed-loop is stable (this is assumed in our Assumption 2 and in Assumption (A2) of [22]), the stability of the equivalent cascaded structure (10) reduces to the stability of the second subsystem (10b). When constraining v_1 to be selected as in (17), a necessary (but not sufficient because of the presence of saturation) condition for (10b) to be stable is that the system is stable for small signals, where the saturation is not active. The corresponding equations with (17), written in the Laplace domain, are given by

$$\begin{aligned} s x_{aw}(s) - x_{aw}(0) &= A x_{aw}(s) + e^{-s\tau_I} B v_1(s) \\ v_1(s) &= -e^{-s\tau_O} D_c(s) C x_{aw}(s) - e^{-s(\tau_I + \tau_O)} D_c(s) D v_1(s), \end{aligned}$$

whose state matrix corresponds to the matrix S defined above.

The anti-windup solution in [22] was motivated by the goal of minimizing the mismatch between the controller states in the unconstrained and anti-windup responses. When reinterpreted within the cascaded structure (10), it becomes clear that this solution is a specific selection among a family of solutions parametrized by the signal v_1 . Indeed, as shown in the proof of the theorem, regardless of the selection of v_1 (and by way of the compensation signal v_2), the controller states behave exactly as in the unconstrained response and the above mentioned mismatch is always zero. One other relevant selection among these corresponds to the IMC-based anti-windup (see, *e.g.*, [32]) which can be easily extended to the case of dead-time linear plants and corresponds to selecting $v_1 \equiv 0$. Note, however, that both the IMC selection and the selection (17) of [22] are only applicable when the matrix A in (1) is Hurwitz. The approach proposed here, instead, always solves the anti-windup problem as long as A has poles in the closed left-hand plane.

Moreover, when A is Hurwitz, different from the selection (17), which might lead to an unstable closed-loop in some cases, IMC-based anti-windup is always asymptotically stabilizing because the dynamics in (10b)

⁷Actually, in [22, §4], $D_c(s)$ is defined as $L_u := L_3 [I + e^{-s\tau_3} L_1 (I - e^{-s\tau_3} L_2 L_1)^{-1} L_2] L_1$. However, it can be shown that this last expression is equivalent to the more intuitive one reported above.

correspond to the asymptotically stable dynamics of the plant. On the other hand, it is well known that IMC anti-windup solutions often lead to poor closed-loop performance, especially when the plant contains slow modes. Such a performance may be improved by the approach in [22], where an extra (sometimes stabilizing) action is enforced through the nonzero selection (17) for v_1 .

An advantage of our approach is that the anti-windup problem is reduced to a stabilization problem where the performance output z_{aw} needs to be minimized in some sense.⁸ The arising solution, in addition to being stabilizing (thus recovering the stability merits of the IMC approach), would also benefit from the degrees of freedom residing in the selection of compensation signal v_1 . \circ

4 Simulation example

In this section we apply the proposed anti-windup technique to a simple scalar simulation example taken from [15, Example 4]. This example is a control system where the plant is represented by an integrator with a 5 seconds output delay and the controller has a modified Smith predictor structure, as represented in Figure 4. Notice that since the state matrix of the plant is not Hurwitz, then the anti-windup approach of [22] does not provide any stability or performance guarantees. Nevertheless, the corresponding construction can be followed, so we apply it here for comparison purposes.

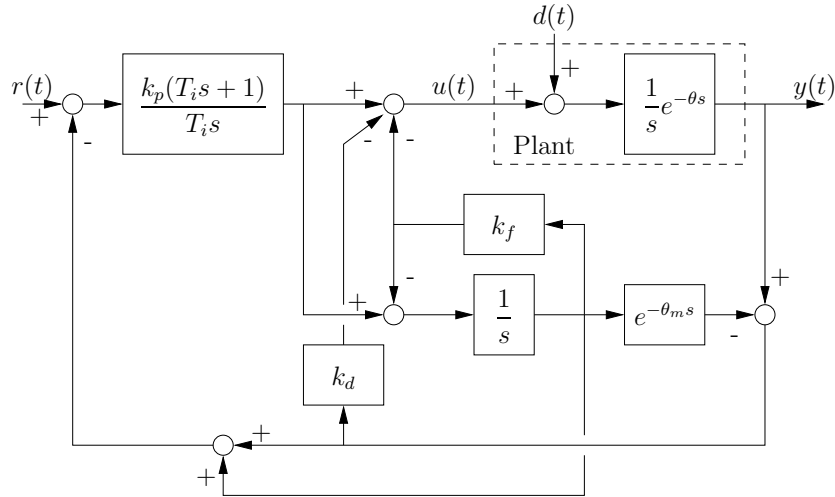

Figure 4: The unconstrained controller for [15, Example 4].

For this particular example, since the plant is an integrator, then $A = 0$ and following the construction at item 2 of Lemma 1, v_1 can be selected as $v_1 = -\rho x_{aw}$, where ρ is an arbitrary positive number. In particular, the larger ρ is, the stronger the anti-windup action will be for the recovery of the unconstrained response. In these simulations we have chosen $\rho = 10$, but different values for ρ could also be selected to suitably impose the speed of convergence of the anti-windup response to the unconstrained one. To apply the technique of [22], according to the comment in Remark 3 (see (17), we select $v_1 = -k_p$. In the simulations, we also compare our anti-windup compensation to the response arising from equipping the closed-loop system with the so-called “tracking anti-windup” that can be applied to the PID controller for this example (following the rule of thumb suggested in [3], we select $T_t = T_i$ in the scheme shown in [3]). Note that for general controllers the tracking anti-windup scheme is not applicable, however for this example it can be used as a comparison means. Note also that the tracking anti-windup scheme does not provide any stability or performance guarantees.

In [15], it is shown that in the absence of saturation (input saturation is not addressed in [15]), the unconstrained controller induces an improved response as compared to previous results. In particular, two

⁸This minimization, at least in the case when A is Hurwitz, can be carried out as suggested in Remark 2.

simulations are reported therein, referred to the nominal case, and to the robust case, where a 10% error is introduced in the delay present at the plant output. In both cases, we select the reference input r and the disturbance input d as follows (similar selections are carried out in [15]):

$$r(t) = \begin{cases} 0, & t < 0 \\ 1, & t \geq 0, \end{cases} \quad d(t) = \begin{cases} 0, & t < 15 \\ -0.05, & t \geq 15, \end{cases} \quad (18)$$

Here we insert a saturation with limits ± 0.1 at the plant input. The unconstrained, saturated, tracking anti-windup Park/Choi anti-windup and our anti-windup responses in the nominal case are reported in Figure 5 using bold solid, solid, dashed, dotted and bold dashed curves, respectively. As in [15], the parameters of the plant and unconstrained controller for this simulation are selected as

$$\theta = 5, \theta_m = 5, k_p = 0.1, T_i = 0.01, k_f = 4.131, k_d = 0.105.$$

In Figure 5, the upper plot compares the plant outputs in the five cases, while the lower plot represents the plant input responses.

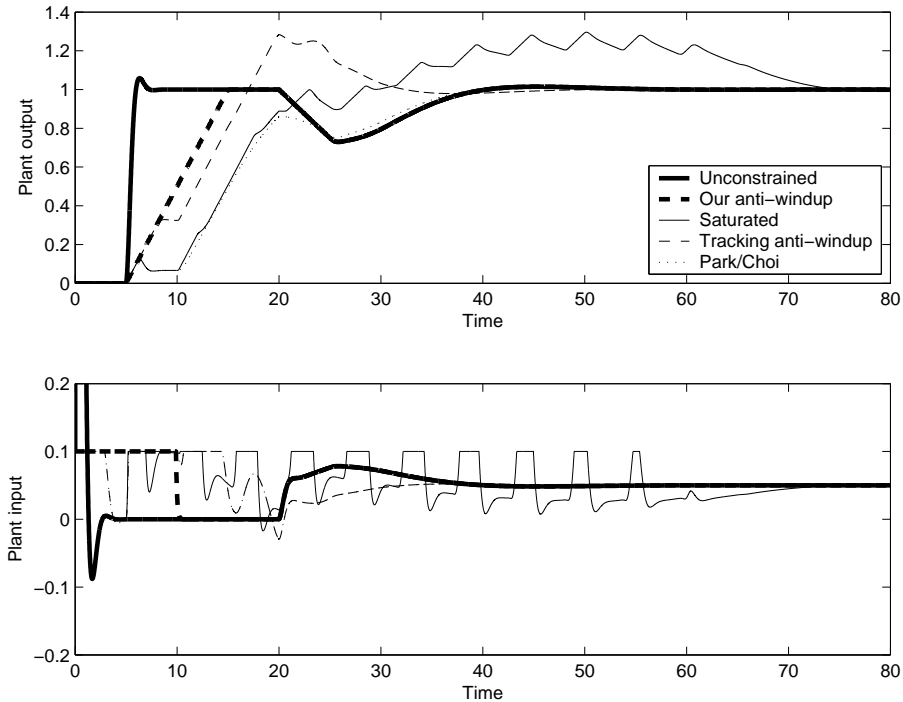

Figure 5: Nominal responses of the unconstrained closed-loop (bold solid), the saturated closed-loop (solid), the closed-loop with tracking anti-windup (dashed), with Park and Choi's anti-windup (dotted) and our anti-windup closed-loop (bold dashed) to the reference and disturbance selection (18).

Note that our anti-windup action is capable of rapidly recovering the performance lost due to input saturation. As a matter of fact, it is seen from the lower plot of Figure 5 that the input is kept into saturation until the output reaches the unconstrained output response (recall that there is a 5 seconds time shift between the input profile and its effect on the output, due to the dead-time characterizing the plant). The saturated response, on the other hand, exhibits undesired overshoots and slowly converges back to the unconstrained response. Tracking anti-windup performs also quite poorly, for this case, although it behaves better in the next response. In general, due to the lack of guarantees, it can be expected to lead to unpredictable behavior. Park and Choi's approach leads to a graceful response with slow convergence to the desired trajectory. Since the disturbance does not cause input saturation for the unconstrained trajectory, the anti-windup response perfectly reproduces the unconstrained response in the second part of the plot, as formally proven in Theorem 1.

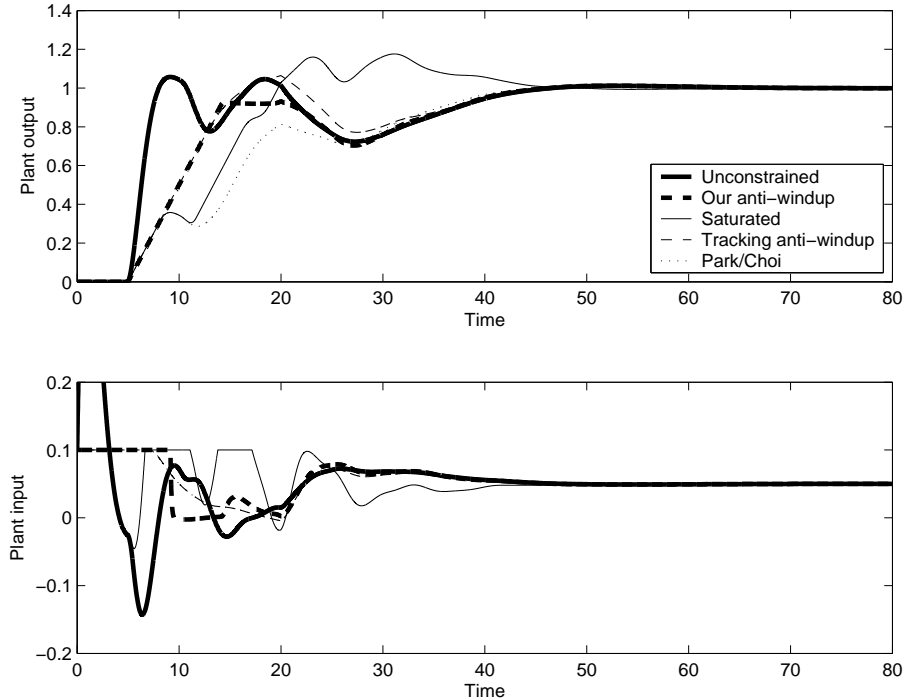

Figure 6: Perturbed responses of the unconstrained closed-loop (bold solid), the saturated closed-loop (solid), the closed-loop with tracking anti-windup (dashed), with Park and Choi’s anti-windup (dotted) and our anti-windup closed-loop (bold dashed) to the reference and disturbance inputs (18).

Figure 6 represents the response of the perturbed system, as described in [15, Example 4]. For the perturbed case, the controller parameters are selected again according to [15] and correspond to

$$\theta = 5, \theta_m = 5.5, k_p = 0.1, T_i = 0.1, k_f = 1.247, k_d = 0.095.$$

Our anti-windup response shows once again good unconstrained response recovery properties, as compared to the saturated response and the other anti-windup responses, thus confirming the robustness properties guaranteed in Theorem 1.

5 Conclusions

In this paper we have formalized the \mathcal{L}_2 anti-windup problem for linear systems with input and output delays. By suitably generalizing the approach in [29] we have given a solution to the robust, nominal, global and local problems whenever one of these is solvable. The corresponding construction is based on the augmentation of the original control scheme with a dynamic filter. Connections with existing results on anti-windup for dead-time systems have been established and the performance of the proposed scheme has been successfully tested on an example taken from the literature.

References

- [1] K.J. Åström and L. Rundqwist. Integrator windup and how to avoid it. In *Proceedings of the American Control Conference*, volume 2, pages 1693–1698, Pittsburgh (PA), USA, June 1989.
- [2] A. Bemporad, A.R. Teel, and L. Zaccarian. \mathcal{L}_2 anti-windup via receding horizon optimal control. In *American Control Conference*, pages 639–44, Anchorage (AK), USA, May 2002.

- [3] C. Bohn and D.P. Atherton. An analysis package comparing PID anti-windup strategies. *IEEE Control Systems Magazine*, 15(2):34–40, April 1995.
- [4] P.H. Chang and S.H. Park. On improving time-delay control under certain hard nonlinearities. *Mechatronics*, 13(4):393–412, May 2003.
- [5] Y.P. Chang, J.S.H. Tsai, and L.S. Shieh. Optimal digital redesign of hybrid cascaded input-delay systems under state and control constraints. *IEEE Trans. on Circ. and Syst. – I: fundamental theory and appl.*, 49(9):1382–1392, September 2002.
- [6] H.A. Fertik and C.W. Ross. Direct digital control algorithm with anti-windup feature. *ISA Transactions*, 6(4):317–328, 1967.
- [7] G. Grimm, J. Hatfield, I. Postlethwaite, A.R. Teel, M.C. Turner, and L. Zaccarian. Antiwindup for stable linear systems with input saturation: an LMI-based synthesis. *IEEE Trans. Aut. Cont. (A)*, 48(9):1509–1525, September 2003.
- [8] G. Grimm, A.R. Teel, and L. Zaccarian. Establishing Lipschitz properties of multivariable algebraic loops with incremental sector nonlinearities. In *Conference on Decision and Control*, Maui (HI), USA, December 2003.
- [9] R. Hanus. Antiwindup and bumpless transfer: a survey. In *Proceedings of the 12th IMACS World Congress*, volume 2, pages 59–65, Paris, France, July 1988.
- [10] R. Hanus, M. Kinnaert, and J.L. Henrotte. Conditioning technique, a general anti-windup and bumpless transfer method. *Automatica*, 23(6):729–739, 1987.
- [11] M.V. Kothare, P.J. Campo, M. Morari, and N. Nett. A unified framework for the study of anti-windup designs. *Automatica*, 30(12):1869–1883, 1994.
- [12] V.V. Kulkarni, S.K. Bohacek, and M.G. Safonov. Robustness of interconnected systems with controller saturation and bounded delays. In *ACC*, pages 3206–3210, San Diego (CA), USA, June 1999.
- [13] B. Lee and J.G. Lee. Robust control of uncertain systems with input delay and input sector nonlinearity. In *CDC*, pages 4430–4435, Sydney (AU), December 2000.
- [14] J.C. Lozier. A steady-state approach to the theory of saturable servo systems. *IRE Transactions on Automatic Control*, pages 19–39, May 1956.
- [15] S. Majhi and D.P. Atherton. Modified Smith predictor and controller for processes with time delay. *IEE Proc. Control Theory Appl.*, 146(5):359–366, September 1999.
- [16] F. Mazenc, S. Mondié, and S.I. Niculescu. Global asymptotic stabilization for chains of integrators with a delay in the input. *IEEE Trans. Aut. Cont.*, 48(1):57–63, January 2003.
- [17] A. Megretski. \mathcal{L}_2 BIBO output feedback stabilization with saturated control. In *13th Triennial IFAC World Congress*, pages 435–440, San Francisco, USA, 1996.
- [18] F. Morabito, A.R. Teel, and L. Zaccarian. Results on anti-windup design for Euler-Lagrange systems. In *IEEE Conference on Robotics and Automation*, pages 3442–7, Washington (DC), USA, May 2002.
- [19] F. Morabito, A.R. Teel, and L. Zaccarian. High performance anti-windup for robot manipulators. In *European Control Conference*, Cambridge (UK), September 2003.
- [20] M. Morari and E. Zafiriou. *Robust process control*. Prentice Hall, Englewood Cliffs, NJ, 1989.
- [21] E.F. Mulder, M.V. Kothare, and M. Morari. Multivariable anti-windup controller synthesis using linear matrix inequalities. *Automatica*, 37(9):1407–1416, September 2001.
- [22] J.K. Park, C.H. Choi, and H. Choo. Dynamic anti-windup method for a class of time-delay control systems with input saturation. *Int. J. Robust and Nonlinear Control*, 10:457–488, 2000.

- [23] K.J. Park, H. Lim, T. Basar, and C.H. Choi. Anti-windup compensator for active queue management in TCP networks. *Control Engineering Practice*, 11(10):1127–1142, October 2003.
- [24] J.C. Shen and F.C. Kung. Stabilization of input-delay systems with saturating actuator. *Int. Journal of Control*, 50(5):1667–1680, 1989.
- [25] O.J.M. Smith. A controller to overcome dead time. *ISA Journal*, 6(2):28–33, February 1959.
- [26] E.D. Sontag. An algebraic approach to bounded controllability of linear systems. *Int. Journal of Control*, 39(1):181–188, 1984.
- [27] S. Tarbouriech, J.M. Gomes da Silva Jr., and G. Garcia. Delay-dependent anti-windup loops for enlarging the stability region of time delay systems with saturating inputs. *ASME Journal of Dynamic Systems, Measurement and Control*, 125:265–267, June 2003.
- [28] A.R. Teel. On \mathcal{L}_2 performance induced by feedbacks with multiple saturations. *ESAIM: Control, Optim. Calc. of Variations*, URL: <http://www.emath.fr/cocv/>, 1:225–240, September 1996.
- [29] A.R. Teel and N. Kapoor. The \mathcal{L}_2 anti-windup problem: Its definition and solution. In *Proc. 4th ECC*, Brussels, Belgium, July 1997.
- [30] L. Zaccarian and A.R. Teel. Nonlinear \mathcal{L}_2 anti-windup design: an LMI-based approach. In *Nonlinear control systems design symposium (NOLCOS)*, pages 1298–1303, Saint-Petersburg, Russia, July 2001.
- [31] L. Zaccarian and A.R. Teel. A common framework for anti-windup, bumpless transfer and reliable designs. *Automatica (B)*, 38(10):1735–1744, 2002.
- [32] A. Zheng, M. V. Kothare, and M. Morari. Anti-windup design for internal model control. *Int. J. of Control*, 60(5):1015–1024, 1994.