

Minerva Access is the Institutional Repository of The University of Melbourne

Author/s:

Javadiyan, S;Craig, JE;Souzeau, E;Sharma, S;Lower, KM;Mackey, DA;Staffieri, SE;Elder, JE;Taranath, D;Straga, T;Black, J;Pater, J;Casey, T;Hewitt, AW;Burdon, KP

Title:

High-throughput genetic screening of 51 pediatric cataract genes identifies causative mutations in inherited pediatric cataract in South Eastern Australia

Date:

2017-10-01

Citation:

Javadiyan, S., Craig, J. E., Souzeau, E., Sharma, S., Lower, K. M., Mackey, D. A., Staffieri, S. E., Elder, J. E., Taranath, D., Straga, T., Black, J., Pater, J., Casey, T., Hewitt, A. W. & Burdon, K. P. (2017). High-throughput genetic screening of 51 pediatric cataract genes identifies causative mutations in inherited pediatric cataract in South Eastern Australia. *G3 Genes Genomes Genetics*, 7 (10), pp.3257-3268. <https://doi.org/10.1534/g3.117.300109>.

Persistent Link:

<https://hdl.handle.net/11343/256924>

License:

[CC BY](#)

High-Throughput Genetic Screening of 51 Pediatric Cataract Genes Identifies Causative Mutations in Inherited Pediatric Cataract in South Eastern Australia

Shari Javadiyan,^{*1} Jamie E. Craig,^{*} Emmanuelle Souzeau,^{*} Shiwani Sharma,^{*} Karen M. Lower,[†] David A. Mackey,^{‡,§,***} Sandra E. Staffieri,^{§,**,††} James E. Elder,^{**,††} Deepa Taranath,^{*} Tania Straga,^{**} Joanna Black,^{**} John Pater,^{**} Theresa Casey,^{**} Alex W. Hewitt,^{**,††,§§,***} and Kathryn P. Burdon^{***}
^{*}Department of Ophthalmology and [†]Department of Haematology and Genetic Pathology, School of Medicine, Flinders University, Adelaide, South Australia 5042, Australia, [‡]Centre for Ophthalmology and Visual Science, University of Western Australia, Lions Eye Institute, Perth, Western Australia 6009, Australia, [§]Centre for Eye Research Australia, Royal Victorian Eye and Ear Hospital, Melbourne, Victoria 3002, Australia, ^{**}Department of Surgery and ^{§§}Department of Paediatrics, University of Melbourne, Victoria 3010, Australia, ^{††}Department of Ophthalmology, Royal Children's Hospital, Melbourne, Victoria 3052, Australia, ^{**}Ophthalmology Department, Women's and Children's Hospital, Adelaide, South Australia 5006, Australia, and ^{***}Menzies Institute for Medical Research, University of Tasmania, Hobart, Tasmania 7000, Australia

ABSTRACT Pediatric cataract is a leading cause of childhood blindness. This study aimed to determine the genetic cause of pediatric cataract in Australian families by screening known disease-associated genes using massively parallel sequencing technology. We sequenced 51 previously reported pediatric cataract genes in 33 affected individuals with a family history (cases with previously known or published mutations were excluded) using the Ion Torrent Personal Genome Machine. Variants were prioritized for validation if they were predicted to alter the protein sequence and were absent or rare with minor allele frequency <1% in public databases. Confirmed mutations were assessed for segregation with the phenotype in all available family members. All identified novel or previously reported cataract-causing mutations were screened in 326 unrelated Australian controls. We detected 11 novel mutations in *GJA3*, *GJA8*, *CRYAA*, *CRYBB2*, *CRYGS*, *CRYGA*, *GCNT2*, *CRYGA*, and *MIP*; and three previously reported cataract-causing mutations in *GJA8*, *CRYAA*, and *CRYBB2*. The most commonly mutated genes were those coding for gap junctions and crystallin proteins. Including previous reports of pediatric cataract-associated mutations in our Australian cohort, known genes account for >60% of familial pediatric cataract in Australia, indicating that still more causative genes remain to be identified.

KEYWORDS

Ion Torrent
PGM
congenital
cataract
pediatric cataract
massively parallel
sequencing
Mutant Screen
Report

Pediatric cataract is one of the leading causes of blindness in children. Approximately 200,000 children worldwide are blind from this

condition (Chan *et al.* 2012). In industrialized countries, the incidence is 1–6 per 10,000 live births (Santana and Waiswo 2011). In Australia, the incidence is 2.2 per 10,000 live births, making the condition one of the most common causes of visual impairment in children (Wirth *et al.* 2002). Intrauterine infection, drug exposure, metabolic disorders, malnutrition, and heredity are known risk factors for pediatric cataract (Churchill and Graw 2011). Pediatric cataract is often referred to as congenital or infantile cataract when it presents at birth or in the first year of life, and juvenile cataract when it presents later during childhood (Yi *et al.* 2011).

Around 25–33% of pediatric cataracts are inherited (Santana *et al.* 2009). It is thought that 28% of bilateral pediatric cataract cases have a genetic basis while only 2% of unilateral cases are genetic (Rahi and Dezateux 2001; Santana and Waiswo 2011). Genetic and clinical

Copyright © 2017 Javadiyan *et al.*

doi: <https://doi.org/10.1534/g3.117.300109>

Manuscript received October 23, 2016; accepted for publication August 15, 2017; published Early Online August 23, 2017.

This is an open-access article distributed under the terms of the Creative Commons Attribution 4.0 International License (<http://creativecommons.org/licenses/by/4.0/>), which permits unrestricted use, distribution, and reproduction in any medium, provided the original work is properly cited.

Supplemental material is available online at www.g3journal.org/lookup/suppl/doi:10.1534/g3.117.300109/-/DC1.

[†]Corresponding author: Department of Ophthalmology, School of Medicine, Flinders University, Flinders Medical Centre, Flinders Dr., Bedford Park, Adelaide, SA 5042, Australia. E-mail: Shahra_80@yahoo.com

heterogeneity have been reported in inherited pediatric cataracts (Lorenz 2007). Inherited cataracts can be transmitted as autosomal recessive, autosomal dominant, or X-linked traits, with autosomal dominant being the most common mode of inheritance. They can be isolated (nonsyndromic) or combined with other phenotypic features (syndromic) (Hejtmančík 2008).

Changes in lens development including lens fiber cell differentiation, protein solubility and stability, and defects in lens structure can lead to the development of cataract (Huang and He 2010). Mutations in genes involved in these functions have been reported to cause pediatric cataract. The known genes include at least 10 crystallin genes (Churchill and Graw 2011; Berry *et al.* 2001; Kannabiran *et al.* 1998; Riazuddin *et al.* 2005; Willoughby *et al.* 2005; Litt *et al.* 1997, 1998; AlFadhli *et al.* 2012; Heon *et al.* 1999), as well as membrane proteins [*MIP*, *LIM2* (Pras *et al.* 2002; Berry *et al.* 2000)]; gap junction proteins [*GJA8*, *GJA3* (Beyer and Berthoud 2014)], cytoskeletal proteins [*BFSP1*, *BFSP2* (Ramachandran *et al.* 2007; Jakobs *et al.* 2000)]; stress response genes [*HSF4* (Bu *et al.* 2002)], cell signaling proteins [*EPHA2* (Shiels *et al.* 2008)], and transcription factors [*PITX3*, *PAX6*, *EYA1*, *FOXE3*, *VSX2*, *FTL* and *MAF* (Churchill and Graw 2011; Burdon *et al.* 2007; Shiels *et al.* 2007; Santana and Waiswo 2011)]. Crystallin and gap junction protein-encoding genes are the most commonly reported classes of genes for nonsyndromic pediatric cataracts, accounting for 50 and 25% of reported mutations, respectively (Hejtmančík 2008).

The large number of genes known to cause pediatric cataract and the limited genotype-phenotype correlations make clinical testing using traditional sequencing technologies challenging and expensive. Massively parallel (next-generation) sequencing (MPS) technologies are now accessible and are cost-effective tools to screen many candidate genes in parallel. In this study, we screened our repository of South Eastern Australian individuals with familial pediatric cataract for mutations in known causative genes using the Ion Torrent Personal Genome Machine (PGM). We hypothesized that a significant proportion of familial pediatric cataract cases would be accounted for by mutations in known genes, and that screening genes in parallel would be an effective method for genetic testing in this heterogeneous disease.

MATERIALS AND METHODS

Participants' recruitment and DNA extraction

The study adhered to the tenets of the Declaration of Helsinki and was approved by the Southern Adelaide Clinical Human Research Ethics Committee, Adelaide, Australia, and the Royal Victorian Eye and Ear Hospital (RVEEH) Human Research and Ethics Committee, Melbourne, Australia. The probands in each family were recruited from the eye clinic at Flinders Medical Centre (Adelaide), the Women's and Children's Hospital (Adelaide), the Royal Children's Hospital (Melbourne), or the Royal Victorian Eye and Ear Hospital (Melbourne). Written informed consent was obtained from all participants or their guardians if they were under 18 years old. A detailed family history was obtained and additional affected and unaffected family members were invited to participate in the study. An ophthalmologist examined all available family members.

Genomic DNA was extracted from either peripheral whole blood using a QiaAmp DNA Blood Maxi Kit (Qiagen, Hilden, Germany) or from saliva using an Oragene DNA saliva collection kit (DNA Genotek, Ontario, Canada) according to the manufacturers' protocols. Participants were included in this study if they reported a family history of

pediatric cataract and if a causative mutation had not previously been detected in the family by other means.

Gene selection, primer design, library preparation, and sequencing

Fifty-one genes known to cause pediatric cataract in human or mouse were selected through review of the literature (Supplemental Material, Table S1 in File S1 (Chen *et al.* 2011; Churchill and Graw 2011; Hughes *et al.* 2011; Lachke *et al.* 2011; Aldahmesh *et al.* 2012; Pras *et al.* 2004; Azuma *et al.* 2000; Nonnenmacher *et al.* 2011; Jamieson *et al.* 2007; Shiels *et al.* 2007; Zhou *et al.* 2010; Ferda Percin *et al.* 2000; Reis *et al.* 2012). The strategy for generating the list included all genes covered in a review of pediatric cataract genes (Churchill and Graw 2011) except the mouse gene *gjf1*, which does not have a human homolog ($n = 39$). A search in PubMed using the terms "paediatric cataract" or "congenital cataracts" in combination with "genetic" or "gene" was used to include additional genes from more recent publications and those genes not covered by the review ($n = 12$). We focused on those genes known to be associated with nonsyndromic pediatric cataract, as this was the predominant phenotype in our cohort. In addition, we included some syndromic pediatric cataract genes known to cause a predominantly ocular syndrome (e.g., *PAX6* and *PITX3*) or where pediatric cataract is a major diagnostic feature of the syndrome (*NHS*) as such genes may also contribute to nonsyndromic cataract (Gillespie *et al.* 2014).

PCR primers to amplify coding, 3'-, and 5'-untranslated regions of the 51 genes were designed with the Ion AmpliSeq Designer tool v1.22 (Life Technologies, www.ampliseq.com). The final design consisted of a total of 1216 amplicons ranging from 125 to 225 bp, covering 94.26% of the target sequence. Primers were supplied in two 100 nM pools (Life Technologies, Carlsbad, CA). Briefly, the concentration of genomic DNA was determined using the dsDNA HS Assay Kit on a Qubit fluorometer (Life Technologies), and libraries were prepared with the Ion AmpliSeq library kit version 2.0 according to manufacturer's protocols. Libraries were prepared in two pools per individual, and the amplified pools were combined before partially digesting the primers and barcode adaptor ligation. The amplified library was diluted to 10 pM, and 25 μ l of the diluted library was used for template preparation using Ion PGM Template OT2 200 Kit (Life Technologies) and the manufacturer's protocol. The clonally amplified library was then enriched on an Ion OneTouch enrichment system. Samples were barcoded during library preparation using Ion Xpress Barcode Adapters 1–16 kit (Life Technologies) and pooled in groups of 3–5 during template preparation on the Ion OneTouch.

Libraries were quantified either with a Bioanalyzer 2100 (Agilent Technologies, Santa Clara, CA) using the High Sensitivity DNA Kit (Agilent Technologies), or by qPCR using the Ion library TaqMan quantification kit (Life Technologies). Sequencing was performed on an Ion Torrent PGM using The Ion PGM Sequencing 200 Kit v2 and an Ion 318 chip (Life Technologies).

Torrent Suite (version 3.6) was used to align reads to human genome reference sequence 19 (hg19). The Coverage Analysis plugin (v4.0-r77897) was used to calculate the number of mapped reads, the percentage of on-target reads, and the mean depth of reads. Variants were called using the Variant caller plugin (V4.0-r76860) with the germline algorithm [allele frequency of 0.15, minimum read quality of 10, and minimum coverage of 20 were set as cut-offs for both indels and single nucleotide polymorphisms (SNPs)]. For annotation, variant call format (VCF) files were uploaded to Ion Reporter V4.0 (<https://ionreporter.lifetechnologies.com/ir/>) using the Ion Reporter Uploader plugin for Torrent Suite (v4.1-r79929). Variants were prioritized for

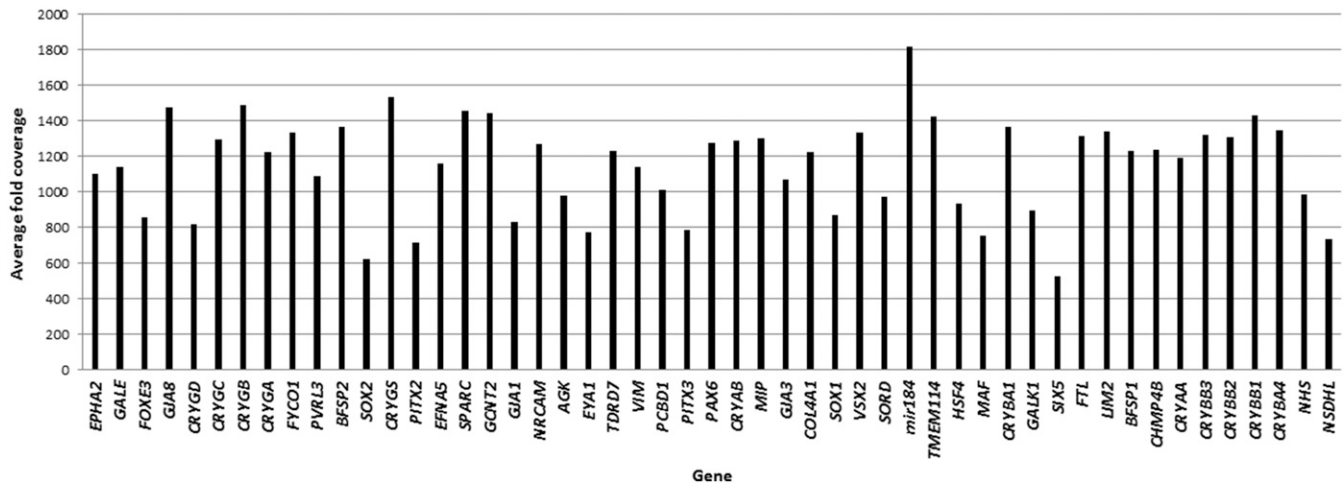

Figure 1 Average fold coverage of target genes sequenced from AmpliSeq libraries in 33 probands with pediatric cataract.

further analysis if they were predicted to be protein-changing, and were absent or rare with minor allele frequency (MAF) <1% in dbSNP137 (<http://www.ncbi.nlm.nih.gov/projects/SNP/>), the Exome Aggregation Consortium (ExAC) (<http://exac.broadinstitute.org/>), and gnomAD (<http://gnomad.broadinstitute.org/>). In addition, identified variants were compared with an in-house list of common sequencing errors previously detected with this gene panel.

Validation, segregation analysis, and evaluating potential functional effects of mutations

Direct Sanger sequencing was used to confirm the detected protein-changing mutations in probands and to evaluate the segregation of the mutation in families. Forward and reverse primer sequences were designed using Primer3 (Untergasser *et al.* 2012; Koressaar and Remm 2007) and are listed in Table S2 in File S1.

PCR reactions of 20 μ l final volume consisted of 1 \times Coraload PCR buffer (Qiagen), which gave a final concentration of 1.5 mM Mg²⁺, 0.1 mM dNTPs (Roche Diagnostics, Risch-Rotkreuz, Switzerland), 0.5 μ M of each primer, 0.5 U Hot Star Plus Taq Polymerase (Qiagen), and 40 ng of gDNA. Five times Q Solution (Qiagen) was included at a final concentration of 1 \times as required, and water volume was adjusted accordingly. PCR was performed on a Palm Cycler (Corbett Life science, Qiagen) with one cycle at 95° for 5 min, followed by 30 or 35 cycles (Table S2 in File S1) at 95° for 30 sec, 57–65° (annealing temperature, Table S2 in File S1) for 30 sec, and 72° for 30 sec, and a final extension step at 72° for 5 min. To clean the PCR products for sequencing, 5 μ l of PCR product, 2 μ l shrimp alkaline phosphatase (SAP; 1 unit/ μ l) and 0.5 μ l (20 units/ μ l) of exonuclease 1 (Exo1) (New England Biolabs, Massachusetts) were mixed. Reactions were incubated at 37° for 1 hr, followed by incubation at 80° for 20 min to inactivate the enzymes.

Sequencing reactions were prepared with the respective forward primer at 5 μ M and purified PCR product at 10 ng/100 bp (*i.e.*, 30 ng for 300 bp product) combined with BigDye Terminator v3.1 (Life Technologies) and 5 \times Sequencing Buffer (Life Technologies), and made up to 20 μ l with water. Reactions were taken through a cycle sequencing PCR protocol on a MasterCycler thermal cycler (Eppendorf, Hamburg, Germany). PCR extension products were purified using Agencourt CleanSeq Magnetic Beads and a SPRI plate, according to the manufacturer's protocol (Beckman Coulter, California). Purified extension products were then resolved using POP-7 polymer on the 3130xl Genetic

Analyzer (Life Technologies) in the Flinders Sequencing Facility (Flinders Medical Centre, Adelaide, Australia).

Sequence chromatograms of affected and unaffected individuals were compared to each other and the reference sequence using Sequencher v.5 (GeneCodes Corporation, Ann Arbor, MI).

Each confirmed segregating novel mutation was assessed for a potential functional effect on the predicted protein sequence using SIFT (Sorting Intolerant from Tolerant, <http://sift.jcvi.org/>) (Kumar *et al.* 2009) and Polyphen-2 (version 2.2.2; the default HumDiv model was used) (Adzhubei *et al.* 2010) (<http://genetics.bwh.harvard.edu/pph2/>). The conservation of each altered amino acid was calculated using PhyloP as implemented in Mutation Taster (<http://www.mutationtaster.org/>) and available through the University of California Santa Cruz (UCSC) genome browser. PhyloP values between –14 and +6 indicate conservation at individual nucleotides, ignoring the effects of their neighbors. Amino acid conservation across species was visualized using the Mutation Taster website. Clinical interpretation of genetic variants by the 2015 ACMG/AMP guideline was determined using InterVar (<http://wintervar.wglab.org/>) (Li and Wang 2017; Richards *et al.* 2015).

Screening novel or previously reported variants in control population

Novel variants were screened in 326 unrelated normal Australian controls recruited from Flinders Medical Centre, Adelaide, using the MassArray platform and iPLEX chemistry (Sequenom) at the Australian Genome Research Facility (Brisbane, Australia). Variants identified in families CRCH139, CSA133, and CSA95 were screened in controls using custom TaqMan SNP genotyping assays (Life Technologies) on a StepOne Plus real-time PCR instrument (Life Technologies) using standard manufacturer's protocols. All variants reported in this study have been submitted to the ClinVar database (<http://www.ncbi.nlm.nih.gov/clinvar/>; ClinVar accessions SCV000297746–SCV000297762).

Data availability

Table S1 in File S1 contains a list of reported pediatric cataract genes selected for sequencing. PCR primers used to validate novel or rare coding mutations detected by next-generation sequencing are listed in Table S2 in File S1. Table S3 in File S1 contains systemic features of the five participants with syndromic pediatric cataract included in the study. Figure S1 in File S1 shows amplicons with <20 fold coverage.

■ Table 1 List of mutations detected in families

Family	Reported MAF in Public Databases	Novel/Known	Gene	Position in hg19	Nucleotide Change	Protein Change	PhyloP Score	Polyphen-2 (HumDiv)	SIFT	Segregation/ Penetrance	Inheritance	ACMG
CSA95	0	Novel	GJA3	chr13:20717372	c.56C > T	p.(Thr19Met)	6.141	PD	D	Yes/ Full	AD	LP
CSA109	0	Novel	GJA3	chr13:20716962	c.466A > C	p.(Lys156Gln)	3.268	PD	D	Yes/ Full	AD	US
CRCH20	0	Novel	GJA8	chr1:147380155	c.73T > C	p.(Trp25Arg)	4.833	PD	D	Yes/ Incomplete	AD	LP
CSA125	0	Novel	GJA8	chr1:147380566	c.484G > A	p.(Glu162Lys)	5.784	PD	D	Yes/ Full	AD	US
CSA162	0	Known (Vanita et al, 2008) (Ma et al, 2016)	GJA8	chr1:147380216	c.134G > C	p.Trp45Ser	5.786	PD	D	Yes/ Full	AD	P
CSA159	0	Novel	CRYAA	chr21:44592307	c.440delA	p.(Gln147Argfs*48)	NA	NA	NA	Yes/ Full	AD	P
CRVEEH111	gnomAD: 0.00003231	Known (Khan et al, 2007) (Devi et al, 2008)	CRYAA	chr21:44589369	c.160C > T	p.(Arg54Cys)	4.982	PD	T	Yes/ Full	AD	P
CSA94	0	Novel	CRYGS	chr3:186257377-78	c.30_31delCTinsAA	p.(Phe10_ Tyr11delinsLeuAsn)	NA	PD	D	Yes/ Full	AD	US
CRCH139	ExAc:0.00428 gnomAD: 0.003861 dbSNP:0.0022 (rs139353014)	Novel	CRYGA	chr2:209027941	c.239G > A	p.(Arg80His)	0.799	PD	T	Yes/ Incomplete	AD	LB
CSA133	0.001904 dbSNP: 0.00006 (rs79006549)	Novel	PVRL3	chr3:110841054	c.886A > C	p.(Asn296His)	4.027	PD	D	No		US
CRVEEH85	0 ExAc: 8.489 x 10 ⁻⁶ gnomAD: 4.085 x 10 ⁻⁶	Known (Litt et al, 1997) Novel Novel	CRYBB2 CRYBB2 BFSP2	chr22:25627584 chr22:25627684 chr3:133191301	c.463C > T c.563G > T c.1136C > A	p.(Gln155*) p.(Arg188Leu) p.(Ala379Glu)	NA 5.11 0.366	NA PD B	D D T	Yes/ Full Yes/ Full Yes/ Full	AD AD AD	P LP US
CRCH89	0	Novel	GCNT2	chr6:10626722	c.1091T > C	p.(Phe364Ser)	4.256	PD	D	Yes/ homozygous in cases/Full	AR	LP
CRCH136	0	Novel	GCNT2	chr6:10626796	c.1169_1172delATCA	p.(Asn388Arg*20)	NA	NA	NA	Yes/ heterozygous in cases/NA	AR	US
CSA131	0 gnomAD: 0.00002439	Novel Novel	MIP FYCO1	chr12:56845225 chr3:46009288	c.631G > T c.1538G > A	p.(Gly211*) p.(Arg513Gln)	NA NA	NA B	NA T	Yes/Full No	AD AD	US US

MAF, minor allele frequency; PD, probably damaging; D, damaging; AD, autosomal dominant; LP, likely pathogenic; US, uncertain significance; P, pathogenic; NA, not applicable; T, tolerated; LB, likely benign; B, benign; AR, autosomal recessive. GenBank accession numbers are shown in Table S1 in File S1. Zero in second column indicates that the variant was not present in all three databases (ExAc, genome ID and dbSNP).

■ **Table 2** Observed phenotypes in families with causative mutations identified in pediatric cataract associated genes

Family	Gene	Affected Members	Phenotype	Age at Diagnosis	Age at Surgery Right Eye	Age at Surgery Left Eye
CSA95	GJA3	CSA95.01	—	0 yr	0 yr	0 yr
		CSA95.02	—	20 yr	—	—
CSA109	GJA3	CSA109.01	Fetal nuclear cataract	3 yr	—	—
		CSA109.02	Fetal nuclear/lamellar cataract	5 yr	16 yr	17 yr
CRCH20	GJA8	CRCH20.02	Bilateral congenital nuclear	—	35 yr	—
		CRCH20.07	Bilateral minor lens opacities	—	—	—
CSA125	GJA8	CSA125.01	Nuclear	10 yr	—	—
		CSA125.02	Posterior polar	—	6 yr	—
CSA162	GJA8	CSA162.01	—	—	—	—
		CSA162.02	—	—	—	—
CSA159	CRYAA	CSA159.01	Severe congenital	0 yr	1 mo	2 mo
		CSA159.02	Nuclear and cortical, blue-dot component: mild	19 yr	25 yr	25 yr
		CSA159.04	Lamellar: mild	4 yr	NA	NA
CRVEEH111	CRYAA	CRVEEH111.01	Bilateral	—	—	—
		CRVEEH111.04	Bilateral	—	17 mo	17 mo
		CRVEEH111.05	Central, anterior polar rider, faint nuclear opacity only	—	—	—
		CRVEEH111.06	Central nuclear opacity	—	—	—
CSA94	CRYGS	CSA94.01	Lamellar cortical-nuclear clear	6 yr	6 yr	5 yr
		CSA94.02	Cortical	4 yr	6 yr	5 yr
		CSA94.03	Lamellar	2 yr	3 yr	4 yr
		CSA94.04	Lamellar	2 yr	5 yr	5 yr
CRCH139	CRYGA	CRCH139.02	Congenital	—	—	—
CSA133	CRYBB2	CSA133.01	—	—	—	—
		CSA133.03	—	—	—	—
CRVEEH85	CRYBB2	CRVEEH85.01	Congenital	—	—	—
		CRVEEH85.02	Congenital	2–3 yr	3 yr	3 yr
		CRVEEH85.03	Congenital	—	—	—
CRCH89	GCNT2	CRCH89.01	Bilateral congenital	—	3 wk	3 wk
		CRCH89.02	Bilateral congenital	—	1 yr	1 yr
		CRCH89.05	Bilateral congenital	—	—	—
		CRCH89.07	Bilateral congenital	—	—	—
CRCH136 ^a	GCNT2	CRCH136.01	Bilateral dense central opacity	—	—	—
		CRCH136.02	Bilateral dense central opacity	—	—	—
CSA131	MIP	CSA131.01	White dots	20 yr	NA	NA
		CSA131.02	White dots	22 yr	NA	NA
		CSA131.04	Cortical and nuclear sclerotic, multiple cortical dots as well as anterior cortical spokes	45 yr	46 yr	46 yr

Missing data are indicated by “—”. NA indicates the individual has not had surgery to date.

^aOne heterozygous deletion detected in affected members of this family with autosomal recessive inheritance pattern.

Figure S2, A–C in File S1) shows protein sequence alignments demonstrating the conservation of the altered amino acid in families with causative mutations.

RESULTS AND DISCUSSION

We sequenced 51 known pediatric cataract genes in 33 unrelated probands using Ion Torrent MPS technology. Syndromic cataract was present in 5/33 (15%) probands (syndromic features described in Table S3 in File S1) while 28/33 (85%) probands had isolated pediatric cataract. Primers were designed for 1216 amplicons in the size range of 125–225 bp to cover the 51 known causative genes. In total, 154.1 kb of target sequence was included in the design process with amplicons designed for 94.3% of the target sequence (8.8 kb not covered). The

presence of repetitive sequence, unacceptable GC content, and melting temperatures of the primers outside the optimal range were the main factors limiting primer design for target regions not covered.

The mean number of mapped reads per sample was 1,536,538, with 91% of reads on target. A mean of 1155 reads was achieved per amplicon, with a coverage uniformity of 89%. Of all the amplicons, 96 and 91% were covered at least 20 and 100 fold, respectively. The average coverage per gene is shown in Figure 1. Of the 1216 amplicons, 30 amplicons (2%) across 17 genes were covered <20 fold (Figure S1 in File S1).

A total of 4726 variants were annotated (an average of 139 variants per individual). In total, 178 variants were absent/rare (MAF <1%) in publically referenced databases, of which 56 were nonsynonymous exonic variants. Twenty-three variants were selected for validation

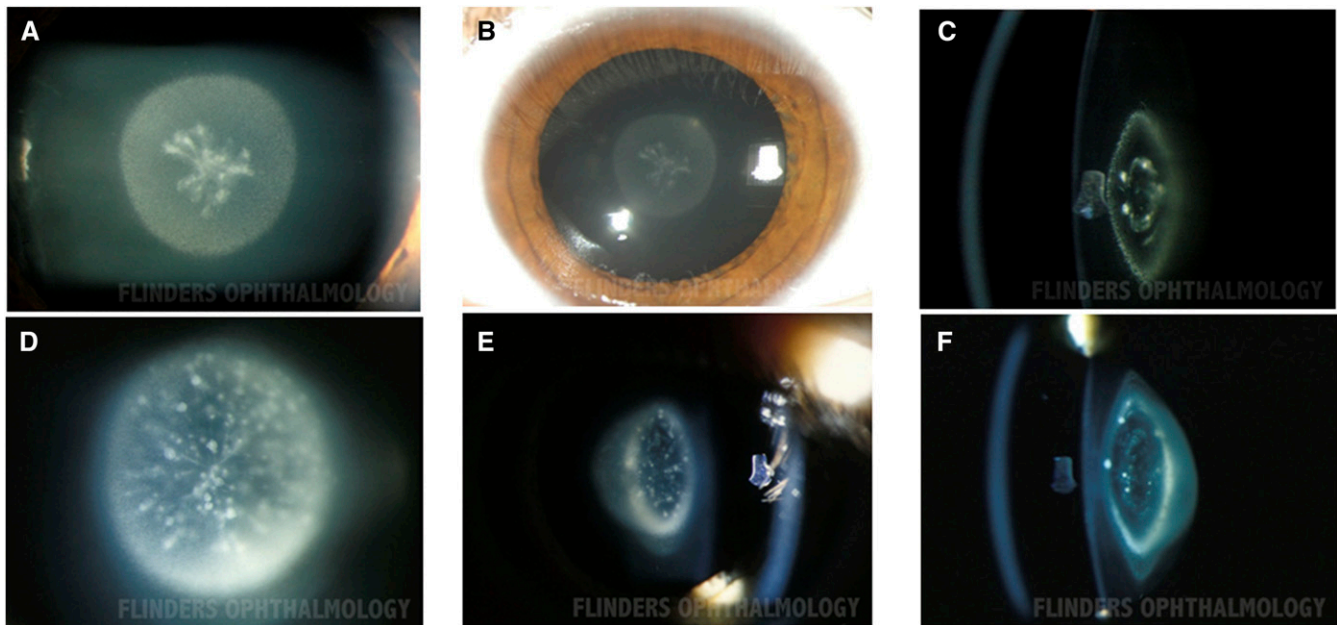

Figure 2 Phenotype of pediatric cataract in family CSA109 carrying causative mutations in *GJA3*. Photographs of individual CSA109.01 A–C show fetal nuclear cataract. D–F show fetal nuclear/lamellar cataract in individual CSA109.02.

using Sanger sequencing after filtering out the variants in an in-house list of sequencing artifacts (33 variants). Seventeen variants were validated and six were false positives.

Of the 17 validated variants (Table 1), 14 appeared to be the likely cause of cataract in the respective families, accounting for 42% of the 33 screened probands. The validated mutations were considered to be pathogenic if the protein change was predicted to be pathogenic by SIFT (Kumar *et al.* 2009) and/or Polyphen-2 (Adzhubei *et al.* 2010), the variant segregated with the phenotype in the family, and was absent from all screened local controls. Two of the 17 validated variants did not segregate, and one was considered benign by both SIFT and Polyphen-2. All segregating mutations were highly conserved across species (Figure S2, A–C in File S1 and Table 1). We have used Polyphen-2 and SIFT predictions as a pathogenicity indicator guide; however, the predictions based on ACMG (Richards *et al.* 2015; Li and Wang 2017) guideline were also included for clinical purposes. The variants predicted to have uncertain significance under ACMG guideline look promising based on the evidence generated in this study; however, additional studies will be needed to confirm their pathogenicity.

In total, as shown in Table 1, we detected 11 novel mutations in eight different genes (*GJA3*, *GJA8*, *CRYAA*, *CRYBB2*, *CRYGS*, *CRYGA*, *GCNT2*, *CRYGA*, and *MIP*), three previously reported cataract-causing mutations in three different genes (*GJA8*, *CRYAA*, and *CRYBB2*). The phenotype in each of the 14 families is given in Table 2, and representative clinical photos where available are shown in Figure 2.

We identified novel mutations in two gap junction genes (*GJA3* and *GJA8*) in five families. Of the two families (CSA95 and CSA109) with mutations in *GJA3*, phenotypic information was not available for family CSA95, but variant p.Thr19Met was predicted to be pathogenic and segregated in the two affected individuals (Figure 3). Both tested individuals in family CSA109 had fetal nuclear lamellar cataracts (Figure 2) and the variant p.(Lys156Gln) was predicted to be damaging and segregated in two affected siblings. The affected father was not available for testing.

Two of the three families with *GJA8* mutations (CSA125 and CRCH20) had cataracts described as nuclear, with no phenotype

information available for family CRCH162 (Table 2). In family CRCH20 the damaging mutation [p.(Trp25Arg)] segregated in two generations and appeared to have incomplete penetrance, as individual CRCH20.04 carries the mutation but as yet does not have cataract. Mutations in families CSA162 [p.(Trp45Ser)] and CSA125 [p.(Glu162Lys)] were inherited from the affected mother and the affected father, respectively (Figure 3), and segregated with the disease.

Six mutations were identified in crystallin genes. A previously reported mutation (Khan *et al.* 2007; Devi *et al.* 2008) in *CRYAA* [p.(Arg54Cys)] was detected in family CRVEEH111 that segregated with the disease (Figure 4A). SIFT predicted this variant to be tolerated, but Polyphen-2 predicted it to be pathogenic (Table 1). Family CRVEEH111 had central nuclear cataract with varying severity in affected family members. The second mutation detected in *CRYAA* is a novel frameshift deletion [p.(Gln147Argfs*48)] in a consanguineous family (CSA159) displaying autosomal dominant inheritance (Figure 4A). The father and both children carried the mutation; however, the severity of the phenotype varied between affected members. The proband (CSA159.01) was diagnosed at birth and underwent cataract surgery at 1 month of age. His sister (CSA159.04) was diagnosed with a milder lamellar cataract with a similar appearance to that in the father.

One novel and one previously reported mutation were detected in *CRYBB2*. Three affected individuals from family CRVEEH85 carried a novel mutation [p.(Arg188Leu)]. These individuals also carried a variant in *BFSP2* [p.(Ala379Glu)]. However, this variant was reported to be benign by both SIFT and Polyphen-2 and was less conserved. It was therefore considered not pathogenic. A previously reported truncating mutation, p.(Gln155*) (rs74315489), in the *CRYBB2* gene was identified in two affected individuals in family CSA133. No information was available regarding the phenotype in this family. This variant has not been reported in normal populations and was not detected in our local controls, thus is likely pathogenic.

Three mutations were detected in two different γ -crystallin genes. Family CSA94 (Figure 4B) had a novel dinucleotide substitution (c.30_31delCTinsAA) resulting in the substitution of two amino

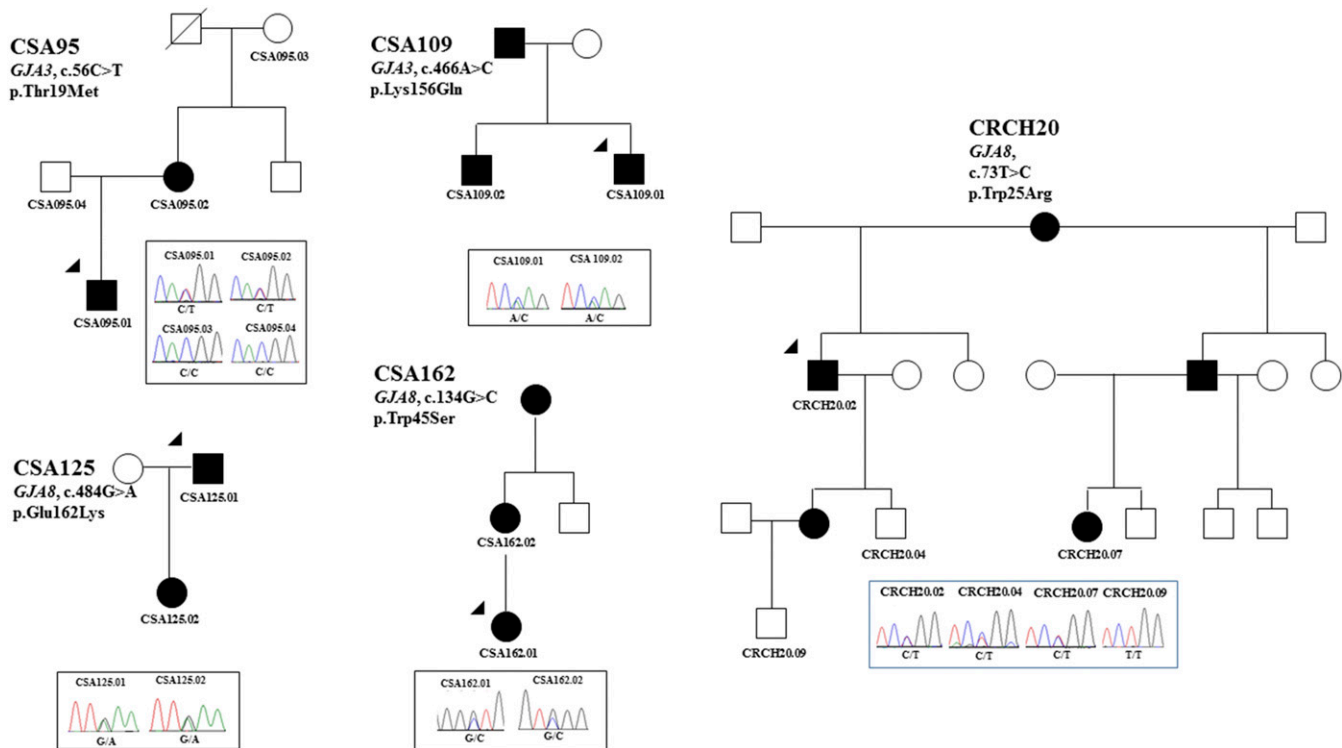

Figure 3 Pedigree and Sanger sequencing analysis of families with variants in gap junction genes (*GJA3* and *GJA8*). The chromatograms below each pedigree show the sequence detected via Sanger sequencing for each variant in families, and the gene names and mutation at cDNA and protein level have been mentioned on each pedigree. The penetrance of mutations in family CRCH20 (*GJA8*, c.73T > C) is incomplete. The arrowheads indicate the proband sequenced on the gene panel by AmpliSeq. Solid circles indicate affected females and solid squares show the affected males.

acids [p.(Phe10_Tyr11delinsLeuAsn)] in *CRYGS* which was predicted to be damaging (Table 1). Affected members of this family had a juvenile onset cortical lamellar cataract and all the members had surgery by 6 yr of age (Table 2). Family CRCH139 had a missense variant [p.(Arg80His), rs139353014] in *CRYGA* segregating with the phenotype in three individuals. This variant was predicted to be damaging by Polyphen-2 and the residue was conserved across species. However, it had a MAF of 0.2% in dbSNP, 0.4% in the ExAC database, and 0.1% in our Australian controls. The variant was also present in an unaffected individual CRCH139.03 in this family (Figure 4B). The reduced penetrance is consistent with this variant being present in the population at lower frequency. A second variant was detected in this family in *PVRL3*; however, it did not segregate with the phenotype. Although it is not clear whether the rare *CRYGA* variant is responsible for the disease in this family, it remains the best candidate mutation observed to date in family CRCH139 and may represent a deleterious variant of lower penetrance.

Families CRCH89 and CRCH136 displayed an autosomal recessive inheritance pattern of cataract. Affected members of the consanguineous family, CRCH89, were homozygous for a novel variant [p.(Phe364Ser)] in *GCNT2* predicted to be pathogenic (Figure 5). The four affected siblings all had bilateral pediatric cataracts with surgery in the first few weeks to 1 year of age (Table 2). A single heterozygous variant in *GCNT2* resulting in a premature stop codon [p.(Asn388Argfs*20)] was detected in family CRCH136 and was inherited from the unaffected mother. No other variant was identified in *GCNT2* in this family.

A segregating stop mutation [p.(Gly211*)] in *MIP* was detected in family CSA131 (Figure 5). The mother (CSA131.04) had cortical and nuclear sclerotic cataracts with multiple cortical dots, while two other

affected members (CSA131.01 and CSA131.02) had anterior cortical spokes and white dot cataracts (Table 2). This family also carried a mutation in *FYCO1*; however, the latter variant was predicted to be benign and did not segregate with the disease.

Mutations meeting the criteria for potential pathogenicity were not identified in the remaining 19 families (57%) or the other 43 genes screened on this gene panel.

In this study, we used targeted massively parallel sequencing to identify genetic variants associated with inherited pediatric cataract. We identified likely causative variants in 42% of previously unsolved familial cases. We detected 11 novel mutations contributing to pediatric cataract, confirmed three previously reported mutations, and identified rare coding variants that may be important in the disease. We have previously identified mutations in genes included in this panel in other families in our repository (Sharma *et al.* 2008; Burdon *et al.* 2004a,b, 2007; Reches *et al.* 2007; Dave *et al.* 2013; Craig *et al.* 2003; McLeod *et al.* 2002; Javadiyan *et al.* 2016). When considered together with our earlier published work, these 51 genes account for 62% of familial pediatric cataract, a proportion comparable to that reported in a similar study of patients from the UK (Gillespie *et al.* 2014) and another Australian cohort (Ma *et al.* 2016).

The phenotypes observed in these families, where detailed information is available, are similar to previous reports of mutations in these genes. For example, we describe predominantly nuclear phenotypes related to mutations in the gap junction genes *GJA3* and *GJA8* (Shiels *et al.* 2010). Similarly, nuclear or total cataracts are observed in *CRYAA* mutation carriers (Khan *et al.* 2007; Devi *et al.* 2008) while mutations in *CRYBB2* give rise to cortical and lamellar cataracts (Devi *et al.* 2008; Faletta *et al.* 2013).

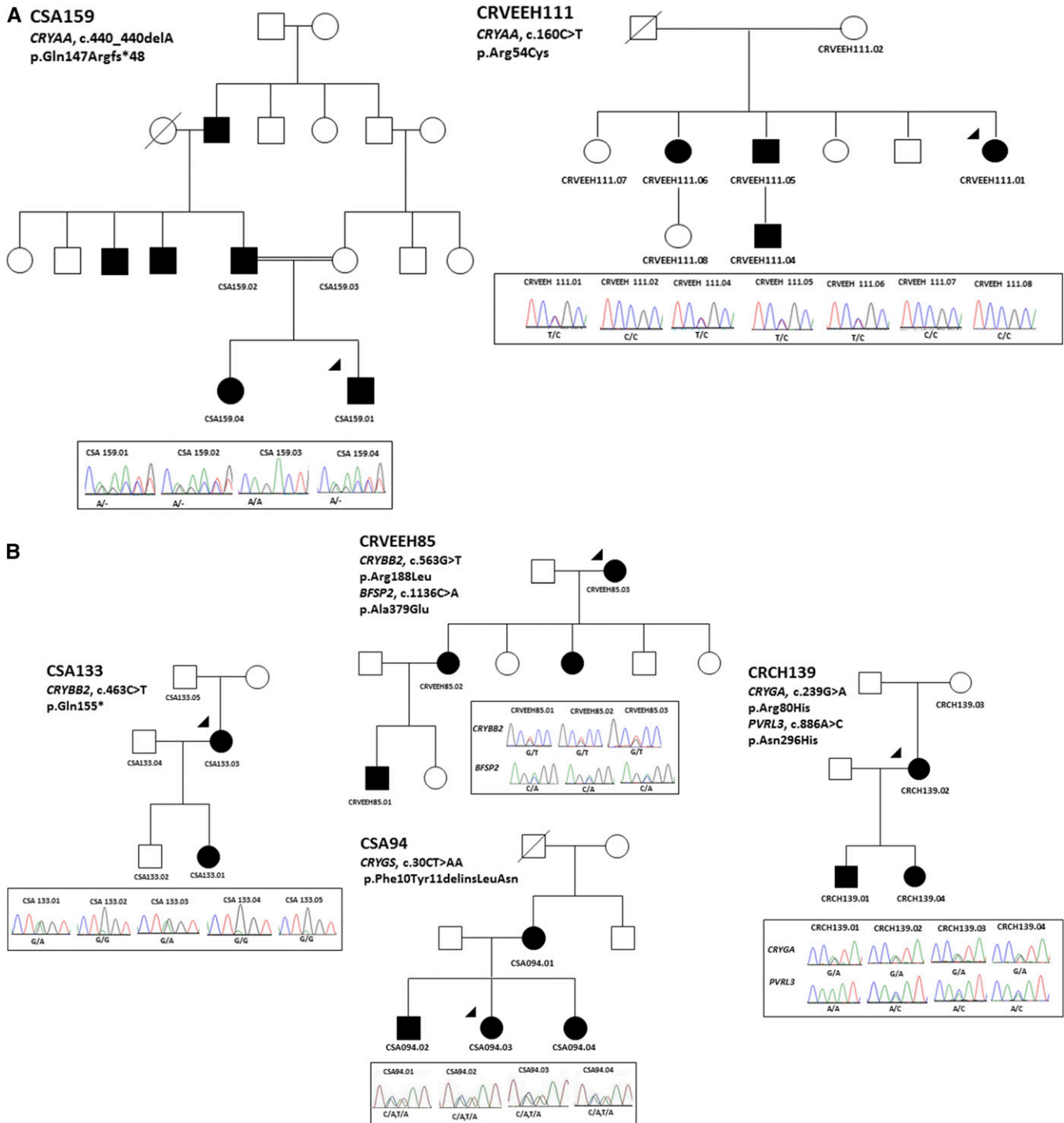

Figure 4 Pedigree and Sanger sequencing analysis of families with variants in (A) α crystallins (CRYAA); (B) β and γ crystallins (CRYBB2, CRYGA, and CRYGS). The penetrance of mutations in family CRCH139 (CRYGA, c.239G > A) is incomplete. The variants in PVRL3 in CRCH139 do not segregate with the phenotype. The segregating variant in BFAP2 in CRVEEH85 was predicted to be nonpathogenic by both SIFT and Polyphen-2. The arrowheads indicate the proband sequenced on the gene panel by AmpliSeq. Solid circles indicate affected females and solid squares show the affected males. Diagonal lines indicate the person is deceased. The chromatograms below each pedigree show the Sanger sequencing result of each detected variant in family members. The gene names and mutation at cDNA and protein level have been mentioned on each pedigree.

Homozygous or compound heterozygous mutations in GCNT2 have been reported in families with autosomal recessive cataract (Borck *et al.* 2012). Affected individuals in family CRCH136 carry a single copy of a 4 bp frameshift deletion [p.(Asn388Argfs*20)] in GCNT2. Although segregation in this family is consistent with autosomal recessive inher-

itance (Figure 5), a second mutation in GCNT2 or in any other gene in the panel could not be identified in the proband. The affected individuals had bilateral dense central opacities, similar to those reported by Borck *et al.* (2012) in other families with a homozygous mutation in this gene, and are also similar to those seen in family CRCH89 in which a

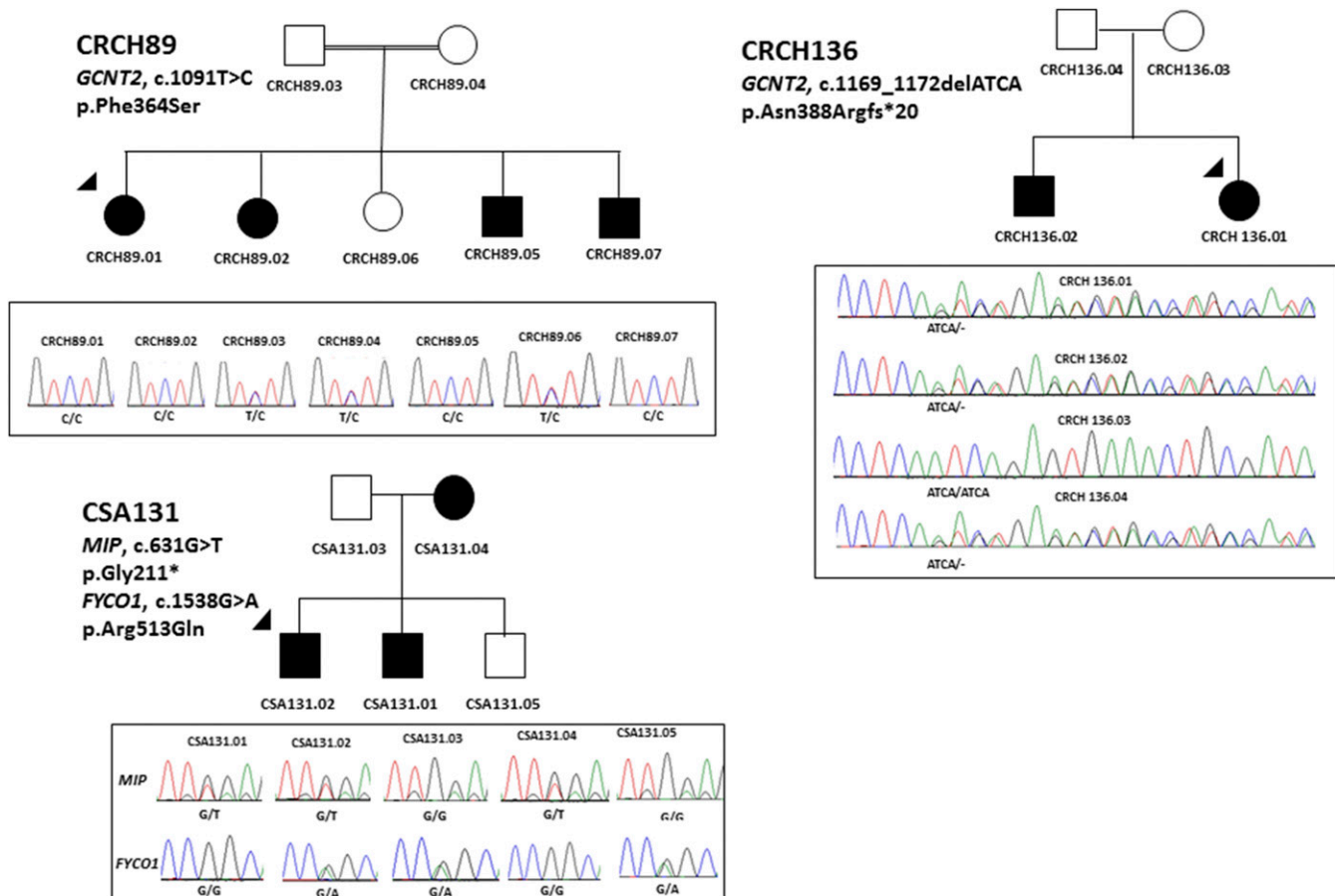

Figure 5 Pedigree and Sanger sequencing analysis of families with variants in *GCNT2* and *MIP*. The arrowheads indicate the proband sequenced on the gene panel by AmpliSeq. Solid circles indicate affected females and solid squares show the affected males. The double line in CRCH89 shows consanguinity. The chromatograms below each pedigree show the segregation analysis of the variants in families. The gene names and mutation at cDNA and protein level have been mentioned on each pedigree.

homozygous *GCNT2* mutation was identified. It is possible that the second mutation in family CRCH136 was not detectable by the methods employed in this study, which may include partial gene deletions or mutations affecting noncoding regions. The possibility that this mutation does not contribute to the disease in this family cannot be excluded but is considered less likely.

This work highlights the not-infrequent occurrence of mutations with incomplete penetrance in pediatric cataract. We observed reduced penetrance with mutations in *GJA8* (CRCH20) and *CRYGA* (CRCH139). This suggests the involvement of modifier genes altering the penetrance of these mutations and the severity of the cataract; however, such genes have not yet been identified (Maeda *et al.* 2001). There have been previous reports of reduced penetrance with mutations in *GJA3* in families with total cortical (Devi *et al.* 2005) and nuclear lamellar pulverulent (Burdon *et al.* 2004b) cataracts. Furthermore, there has been one report of reduced penetrance of a mutation in *CRYBB2* associated with congenital zonular cataract (Santhiya *et al.* 2010).

The possible involvement of rare variants present in public databases in pediatric cataract pathogenesis is suggested by this study. Family CRCH139 has a segregating rare variant in *CRYGA* (rs139353014) with incomplete penetrance. Other factors, including high level of conservation at this residue and Polyphen-2 prediction of a functional effect, provide support for contribution of this mutation to cataract in this

family. The incomplete penetrance is consistent with the presence of this variant at very low levels in public databases and our local controls. If this variant does not always lead to disease, it would be expected to accumulate in such databases. As public databases increase in size, and are generated from unscreened individuals, we expect that, increasingly, disease-causing variants will be found at low frequency in these resources. This scenario of disease-causing variants being represented in public databases of genetic variation due to the large numbers of individuals sequenced is well exemplified by the p.Gln368* mutation in the *MYOC* gene, which leads to primary open-angle glaucoma with high penetrance and is present in the 1000 Genomes database with a frequency of 0.06% as rs74315329. Such rare variation should not be automatically discounted when evaluating variants as pathogenic in disease cohorts. SIFT and ACMG predictions of benign for the Arg80His variant of CRCH139 make it difficult to comment on the pathogenicity of this variant without any functional studies. Other possibilities, such as the causative variant being intronic, in a novel not-yet-reported gene (or not included in this panel), or a large structural variant should not be ignored.

In the current study, 2% of amplicons were covered <20 fold, potentially limiting the ability to detect heterozygous mutations in these amplicons. By chance, the majority of the 16 genes containing these low coverage amplicons are involved in syndromic forms of pediatric cataract. In this study, only five probands had syndromic

pediatric cataracts and no mutations were identified in these individuals. It may be that mutations were missed due to low coverage, or that these individuals have mutations in genes not targeted by this panel. Furthermore, it is important to comment that this study is not able to detect large insertions or deletions or any structural variants such as copy number variation (CNV) within screened genes. Such variants have been reported in the literature to be associated with the disease (Siggs *et al.* 2017; Burdon *et al.* 2007; Van Esch *et al.* 2007).

One of the main advantages of the AmpliSeq method on the Ion Torrent PGM is that it only requires 10–40 ng of DNA as starting material. Many of the DNA samples used in this study were >10 years old, and the limited quantity of DNA available was somewhat degraded. The successful sequencing of these samples and identification of likely causative mutations suggests that quality of DNA is not necessarily a crucial factor in obtaining reliable sequencing results using this methodology.

Pediatric cataract is a clinically and genetically heterogeneous condition, which makes accurate molecular diagnosis difficult. Genetic linkage analysis and candidate gene screening are the conventional methods for detecting disease-causing genes for familial diseases, but this approach is limited by the size of the families. In small families, as in this current cohort, gene identification has been difficult due to lack of power for linkage and the excessive cost of screening large numbers of candidate genes using traditional Sanger sequencing. MPS platforms are able to target numerous genes in parallel and are cost-effective tools for gene identification in heterogeneous conditions such as pediatric cataract. In this study, we aimed to determine the genetic contribution of the known pediatric cataract genes to inherited pediatric cataract in an Australian cohort. In our experience, both ophthalmologists and their patients are highly motivated to know the genetic basis of their disease. Developing genetic diagnostic panels increases the chance of obtaining a molecular diagnosis, which allows patients and their families to be better educated about the mode of inheritance, and facilitates more accurate genetic counseling about the risk of recurrence for future pregnancies, enabling discussion regarding possible reproductive options. For example, the parents in family CSA159 enrolled in this research study during a pregnancy with a desire to understand the likelihood of the child being affected with the severe disease observed in their son.

Although some degree of genotype/phenotype correlation is beginning to emerge for some pediatric cataract genes, the clinical evaluation of a patient is often insufficient to establish which genes are most likely involved in order to initiate specific genetic testing. This is particularly the case in historic samples where surgery was performed prior to enrolment in this study. These genotype-phenotype correlations are worthy of further study, as genetic counseling in the future should take account of the likely severity of affected status, the likelihood of systemic manifestation, and the chance of incomplete penetrance. Gene panel testing, as has been shown in previous studies (Gillespie *et al.* 2014) and here in an Australian cohort, is therefore an efficient way to rapidly determine the genetic cause of heterogeneous diseases such as pediatric cataract. In our cohort of cases, the chosen panel of 51 genes would cover 62% of causative mutations.

ACKNOWLEDGMENTS

This work was supported by funding from the Channel 7 Children's Research Foundation, the Ophthalmic Research Institute of Australia, and an Australian National Health and Medical Research Council (NHMRC) Centres of Research Excellence Grant 1023911 (2012F2016). The Centre for Eye Research Australia receives operational infrastructure support from the Victorian Government. J.E.C. is supported by an NHMRC Practitioner Fellowship, and K.P.B. by an NHMRC Se-

nior Research Fellowship. A.W.H. was supported by an NHMRC Early Career Fellowship 1037838 (2012–2015).

LITERATURE CITED

- Adzhubei, I. A., S. Schmidt, L. Peshkin, V. E. Ramensky, A. Gerasimova *et al.*, 2010 A method and server for predicting damaging missense mutations. *Nat. Methods* 7: 248–249.
- Aldahmesh, M. A., A. O. Khan, J. Y. Mohamed, M. H. Alghamdi, and F. S. Alkuraya, 2012 Identification of a truncation mutation of acylglycerol kinase (AGK) gene in a novel autosomal recessive cataract locus. *Hum. Mutat.* 33: 960–962.
- AlFadhli, S., S. Abdelmoaty, A. Al-Hajeri, A. Behbehani, and F. Alkuraya, 2012 Novel crystallin gamma B mutations in a Kuwaiti family with autosomal dominant congenital cataracts reveal genetic and clinical heterogeneity. *Mol. Vis.* 18: 2931–2936.
- Azuma, N., A. Hirakiyama, T. Inoue, A. Asaka, and M. Yamada, 2000 Mutations of a human homologue of the *Drosophila eyes absent* gene (*EYA1*) detected in patients with congenital cataracts and ocular anterior segment anomalies. *Hum. Mol. Genet.* 9: 363–366.
- Berry, V., P. Francis, S. Kaushal, A. Moore, and S. Bhattacharya, 2000 Missense mutations in MIP underlie autosomal dominant 'polymorphic' and lamellar cataracts linked to 12q. *Nat. Genet.* 25: 15–17.
- Berry, V., P. Francis, M. A. Reddy, D. Collyer, E. Vithana *et al.*, 2001 Alpha-B crystallin gene (*CRYAB*) mutation causes dominant congenital posterior polar cataract in humans. *Am. J. Hum. Genet.* 69: 1141–1145.
- Beyer, E. C., and V. M. Berthoud, 2014 Connexin hemichannels in the lens. *Front. Physiol.* 5: 20.
- Borck, G., N. Kakar, J. Hoch, K. Friedrich, J. Freudenberg *et al.*, 2012 An Alu repeat-mediated genomic *GCNT2* deletion underlies congenital cataracts and adult i blood group. *Hum. Genet.* 131: 209–216.
- Bu, L., Y. Jin, Y. Shi, R. Chu, A. Ban *et al.*, 2002 Mutant DNA-binding domain of HSF4 is associated with autosomal dominant lamellar and Marner cataract. *Nat. Genet.* 31: 276–278.
- Burdon, K. P., M. G. Wirth, D. A. Mackey, I. M. Russell-Eggitt, J. E. Craig *et al.*, 2004a Investigation of crystallin genes in familial cataract, and report of two disease associated mutations. *Br. J. Ophthalmol.* 88: 79–83.
- Burdon, K. P., M. G. Wirth, D. A. Mackey, I. M. Russell-Eggitt, J. E. Craig *et al.*, 2004b A novel mutation in the Connexin 46 gene causes autosomal dominant congenital cataract with incomplete penetrance. *J. Med. Genet.* 41: e106.
- Burdon, K. P., S. Sharma, C. S. Chen, D. P. Dimasi, D. A. Mackey *et al.*, 2007 A novel deletion in the *FTL* gene causes hereditary hyperferritinemia cataract syndrome (HHCS) by alteration of the transcription start site. *Hum. Mutat.* 28: 742.
- Chan, W. H., S. Biswas, J. L. Ashworth, and I. C. Lloyd, 2012 Congenital and infantile cataract: aetiology and management. *Eur. J. Pediatr.* 171: 625–630.
- Chen, J., Z. Ma, X. Jiao, R. Fariss, W. L. Kantorow *et al.*, 2011 Mutations in *FYCO1* cause autosomal-recessive congenital cataracts. *Am. J. Hum. Genet.* 88: 827–838.
- Churchill, A., and J. Graw, 2011 Clinical and experimental advances in congenital and paediatric cataracts. *Philos. Trans. R. Soc. Lond. B Biol. Sci.* 366: 1234–1249.
- Craig, J. E., J. B. Clark, J. L. McLeod, M. A. Kirkland, G. Grant *et al.*, 2003 Hereditary hyperferritinemia-cataract syndrome: prevalence, lens morphology, spectrum of mutations, and clinical presentations. *Arch. Ophthalmol.* 121: 1753–1761.
- Dave, A., K. Laurie, S. E. Staffieri, D. Taranath, D. A. Mackey *et al.*, 2013 Mutations in the *EPHA2* gene are a major contributor to inherited cataracts in South-Eastern Australia. *PLoS One* 8: e72518.
- Devi, R. R., C. Reena, and P. Vijayalakshmi, 2005 Novel mutations in *GJA3* associated with autosomal dominant congenital cataract in the Indian population. *Mol. Vis.* 11: 846–852.
- Devi, R. R., W. Yao, P. Vijayalakshmi, Y. V. Sergeev, P. Sundaresan *et al.*, 2008 Crystallin gene mutations in Indian families with inherited pediatric cataract. *Mol. Vis.* 14: 1157–1170.

- Faletta, F., A. P. d'Adamo, S. Pensiero, E. Athanasakis, D. Catalano *et al.*, 2013 A novel CRYBB2 missense mutation causing congenital autosomal dominant cataract in an Italian family. *Ophthalmic Genet.* 34: 115–117.
- Ferda Percin, E., L. A. Ploder, J. J. Yu, K. Arici, D. J. Horsford *et al.*, 2000 Human microphthalmia associated with mutations in the retinal homeobox gene CHX10. *Nat. Genet.* 25: 397–401.
- Gillespie, R. L., J. O'Sullivan, J. Ashworth, S. Bhaskar, S. Williams *et al.*, 2014 Personalized diagnosis and management of congenital cataract by next-generation sequencing. *Ophthalmology* 121: 2124–2137 e2121–2122.
- Hejtmancik, J. F., 2008 Congenital cataracts and their molecular genetics. *Semin. Cell Dev. Biol.* 19: 134–149.
- Heon, E., M. Priston, D. F. Schorderet, G. D. Billingsley, P. O. Girard *et al.*, 1999 The gamma-crystallins and human cataracts: a puzzle made clearer. *Am. J. Hum. Genet.* 65: 1261–1267.
- Huang, B., and W. He, 2010 Molecular characteristics of inherited congenital cataracts. *Eur. J. Med. Genet.* 53: 347–357.
- Hughes, A. E., D. T. Bradley, M. Campbell, J. Lechner, D. P. Dash *et al.*, 2011 Mutation altering the miR-184 seed region causes familial keratoconus with cataract. *Am. J. Hum. Genet.* 89: 628–633.
- Jakobs, P. M., J. F. Hess, P. G. FitzGerald, P. Kramer, R. G. Weleber *et al.*, 2000 Autosomal-dominant congenital cataract associated with a deletion mutation in the human beaded filament protein gene BFSP2. *Am. J. Hum. Genet.* 66: 1432–1436.
- Jamieson, R. V., N. Farrar, K. Stewart, R. Perveen, M. Mihelec *et al.*, 2007 Characterization of a familial t(16;22) balanced translocation associated with congenital cataract leads to identification of a novel gene, TMEM114, expressed in the lens and disrupted by the translocation. *Hum. Mutat.* 28: 968–977.
- Javadiyan, S., J. E. Craig, E. Souzeau, S. Sharma, K. M. Lower *et al.*, 2016 Recurrent mutation in the crystallin alpha A gene associated with inherited paediatric cataract. *BMC Res. Notes* 9: 83.
- Kannabiran, C., P. K. Rogan, L. Olmos, S. Basti, G. N. Rao *et al.*, 1998 Autosomal dominant zonular cataract with sutural opacities is associated with a splice mutation in the betaA3/A1-crystallin gene. *Mol. Vis.* 4: 21.
- Khan, A. O., M. A. Aldahmesh, and B. Meyer, 2007 Recessive congenital total cataract with microcornea and heterozygote carrier signs caused by a novel missense CRYAA mutation (R54C). *Am. J. Ophthalmol.* 144: 949–952.
- Koressaar, T., and M. Remm, 2007 Enhancements and modifications of primer design program Primer3. *Bioinformatics* 23: 1289–1291.
- Kumar, P., S. Henikoff, and P. C. Ng, 2009 Predicting the effects of coding non-synonymous variants on protein function using the SIFT algorithm. *Nat. Protoc.* 4: 1073–1081.
- Lachke, S. A., F. S. Alkuraya, S. C. Kneeland, T. Ohn, A. Aboukhalil *et al.*, 2011 Mutations in the RNA granule component TDRD7 cause cataract and glaucoma. *Science* 331: 1571–1576.
- Li, Q., and K. Wang, 2017 InterVar: clinical interpretation of genetic variants by the 2015 ACMG-AMP guidelines. *Am. J. Hum. Genet.* 100: 267–280.
- Litt, M., R. Carrero-Valenzuela, D. M. LaMorticella, D. W. Schultz, T. N. Mitchell *et al.*, 1997 Autosomal dominant cerulean cataract is associated with a chain termination mutation in the human beta-crystallin gene CRYBB2. *Hum. Mol. Genet.* 6: 665–668.
- Litt, M., P. Kramer, D. M. LaMorticella, W. Murphey, E. W. Lovrien *et al.*, 1998 Autosomal dominant congenital cataract associated with a missense mutation in the human alpha crystallin gene CRYAA. *Hum. Mol. Genet.* 7: 471–474.
- Lorenz, B., 2007 Genetische Untersuchungen bei kongenitaler Katarakt. *Ophthalmologie* 104: 559–565.
- Ma, A. S., J. R. Grigg, G. Ho, I. Prokudin, E. Farnsworth *et al.*, 2016 Sporadic and familial congenital cataracts: mutational spectrum and new diagnoses using next-generation sequencing. *Hum. Mutat.* 37: 371–384.
- Maeda, Y. Y., N. Funata, S. Takahama, Y. Sugata, and H. Yonekawa, 2001 Two interactive genes responsible for a new inherited cataract (RCT) in the mouse. *Mamm. Genome* 12: 278–283.
- McLeod, J. L., J. Craig, S. Gumley, S. Roberts, and M. A. Kirkland, 2002 Mutation spectrum in Australian pedigrees with hereditary hyperferritinaemia-cataract syndrome reveals novel and *de novo* mutations. *Br. J. Haematol.* 118: 1179–1182.
- Nonnenmacher, L., T. Langer, H. Blessing, H. Gabriel, H. J. Buchwald *et al.*, 2011 Hereditary hyperferritinemia cataract syndrome: clinical, genetic, and laboratory findings in 5 families. *Klin. Padiatr.* 223: 346–351.
- Pras, E., E. Levy-Nissenbaum, T. Bakhan, H. Lahat, E. Assia *et al.*, 2002 A missense mutation in the LIM2 gene is associated with autosomal recessive presenile cataract in an inbred Iraqi Jewish family. *Am. J. Hum. Genet.* 70: 1363–1367.
- Pras, E., J. Raz, V. Yahalom, M. Frydman, H. J. Garzozzi *et al.*, 2004 A nonsense mutation in the glucosaminyl (N-acetyl) transferase 2 gene (GCNT2): association with autosomal recessive congenital cataracts. *Invest. Ophthalmol. Vis. Sci.* 45: 1940–1945.
- Rahi, J. S., and C. Dezateux, 2001 Measuring and interpreting the incidence of congenital ocular anomalies: lessons from a national study of congenital cataract in the UK. *Invest. Ophthalmol. Vis. Sci.* 42: 1444–1448.
- Ramachandran, R. D., V. Perumalsamy, and J. F. Hejtmancik, 2007 Autosomal recessive juvenile onset cataract associated with mutation in BFSP1. *Hum. Genet.* 121: 475–482.
- Reches, A., Y. Yaron, K. Burdon, O. Crystal-Shalit, D. Kidron *et al.*, 2007 Prenatal detection of congenital bilateral cataract leading to the diagnosis of Nance-Horan syndrome in the extended family. *Prenat. Diagn.* 27: 662–664.
- Reis, L. M., R. C. Tyler, B. A. Volkmann Kloss, K. F. Schilter, A. V. Levin *et al.*, 2012 PITX2 and FOXC1 spectrum of mutations in ocular syndromes. *Eur. J. Hum. Genet.* 20: 1224–1233.
- Riazuddin, S. A., A. Yasmeen, W. Yao, Y. V. Sergeev, Q. Zhang *et al.*, 2005 Mutations in betaB3-crystallin associated with autosomal recessive cataract in two Pakistani families. *Invest. Ophthalmol. Vis. Sci.* 46: 2100–2106.
- Richards, S., N. Aziz, S. Bale, D. Bick, S. Das *et al.*, 2015 Standards and guidelines for the interpretation of sequence variants: a joint consensus recommendation of the American College of Medical Genetics and Genomics and the Association for Molecular Pathology. *Genet. Med.* 17: 405–424.
- Santana, A., and M. Waiswo, 2011 The genetic and molecular basis of congenital cataract. *Arq. Bras. Oftalmol.* 74: 136–142.
- Santana, A., M. Waiswol, E. S. Arcieri, J. P. Cabral de Vasconcellos, and M. Barbosa de Melo, 2009 Mutation analysis of CRYAA, CRYGC, and CRYGD associated with autosomal dominant congenital cataract in Brazilian families. *Mol. Vis.* 15: 793–800.
- Santhiya, S. T., G. S. Kumar, P. Sudhakar, N. Gupta, N. Klopp *et al.*, 2010 Molecular analysis of cataract families in India: new mutations in the CRYBB2 and GJA3 genes and rare polymorphisms. *Mol. Vis.* 16: 1837–1847.
- Sharma, S., K. P. Burdon, A. Dave, R. V. Jamieson, Y. Yaron *et al.*, 2008 Novel causative mutations in patients with Nance-Horan syndrome and altered localization of the mutant NHS-A protein isoform. *Mol. Vis.* 14: 1856–1864.
- Shiels, A., T. M. Bennett, H. L. Knopf, K. Yamada, K. Yoshiura *et al.*, 2007 CHMP4B, a novel gene for autosomal dominant cataracts linked to chromosome 20q. *Am. J. Hum. Genet.* 81: 596–606.
- Shiels, A., T. M. Bennett, H. L. Knopf, G. Maraini, A. Li *et al.*, 2008 The EPHA2 gene is associated with cataracts linked to chromosome 1p. *Mol. Vis.* 14: 2042–2055.
- Shiels, A., T. M. Bennett, and J. F. Hejtmancik, 2010 Cat-Map: putting cataract on the map. *Mol. Vis.* 16: 2007–2015.
- Shiels, A. H. J., 2007 Genetic origins of cataract. *Arch. Ophthalmol.* 125: 165–173.
- Siggs, O. M., S. Javadiyan, S. Sharma, E. Souzeau, K. M. Lower *et al.*, 2017 Partial duplication of the CRYBB1-CRYBA4 locus is associated with autosomal dominant congenital cataract. *Eur. J. Hum. Genet.* 25: 711–718.
- Untergasser, A., I. Cutcutache, T. Koressaar, J. Ye, B. C. Faircloth *et al.*, 2012 Primer3-new capabilities and interfaces. *Nucleic Acids Res.* 40: e115.

- Van Esch, H., A. Jansen, M. Bauters, G. Froyen, and J. P. Fryns, 2007 Encephalopathy and bilateral cataract in a boy with an interstitial deletion of Xp22 comprising the CDKL5 and NHS genes. *Am. J. Med. Genet. A.* 143: 364–369.
- Vanita, V., J. R. Singh, D. Singh, R. Varon, and K. Sperling, 2008 A mutation in GJA8 (p.P88Q) is associated with “balloon-like” cataract with Y-sutural opacities in a family of Indian origin. *Mol. Vis.* 17: 1171–1175.
- Willoughby, C. E., A. Shafiq, W. Ferrini, L. L. Chan, G. Billingsley *et al.*, 2005 CRYBB1 mutation associated with congenital cataract and microcornea. *Mol. Vis.* 11: 587–593.
- Wirth, M. G., I. M. Russell-Eggitt, J. E. Craig, J. E. Elder, and D. A. Mackey, 2002 Aetiology of congenital and paediatric cataract in an Australian population. *Br. J. Ophthalmol.* 86: 782–786.
- Yi, J., J. Yun, Z. K. Li, C. T. Xu, and B. R. Pan, 2011 Epidemiology and molecular genetics of congenital cataracts. *Int. J. Ophthalmol.* 4: 422–432.
- Zhou, G., N. Zhou, S. Hu, L. Zhao, C. Zhang *et al.*, 2010 A missense mutation in CRYBA4 associated with congenital cataract and microcornea. *Mol. Vis.* 16: 1019–1024.

Communicating editor: R. Cantor