

# Automated radiosynthesis of [<sup>68</sup>Ga]Ga-PSMA-11 and [<sup>177</sup>Lu]Lu-PSMA-617 on the iPHASE MultiSyn module for clinical applications

Christian W. Wichmann<sup>1,2,3,4</sup>  | Uwe Ackermann<sup>1,3,4</sup> | Stan Poniger<sup>3</sup> | Kenneth Young<sup>3</sup> | Benjamin Nguyen<sup>3</sup> | Gordon Chan<sup>3</sup> | John Sachinidis<sup>3</sup> | Andrew M. Scott<sup>1,2,3,4</sup>

<sup>1</sup>Tumor Targeting Laboratory, Olivia Newton-John Cancer Research Institute, Heidelberg, Victoria, Australia

<sup>2</sup>School of Cancer Medicine, La Trobe University, Bundoora, Victoria, Australia

<sup>3</sup>Department of Molecular Imaging and Therapy, Austin Health, Heidelberg, Victoria, Australia

<sup>4</sup>Department of Medicine, University of Melbourne, Parkville, Victoria, Australia

## Correspondence

Christian W. Wichmann, Tumor Targeting Laboratory, Olivia Newton-John Cancer Research Institute, Heidelberg, VIC 3084, Australia.  
Email: christian.wichmann@onjcri.org.au

## Funding information

Victorian Cancer Agency, Grant/Award Number: 1063413; Operational Infrastructure Support from Victorian Government; National Health and Medical Research Council, Grant/Award Numbers: 1092788, 1143710

Prostate-specific membrane antigen (PSMA)-targeted imaging and therapy of prostate cancer using theranostic pairs is rapidly changing clinical practice. To facilitate clinical trials, fully automated procedures for the radiosyntheses of [<sup>68</sup>Ga]Ga-PSMA-11 and [<sup>177</sup>Lu]Lu-PSMA-617 were developed from commercially available precursors using the cassette based iPHASE MultiSyn module. Formulated and sterile radiopharmaceuticals were obtained in  $76 \pm 3\%$  ( $n = 20$ ) and  $91 \pm 4\%$  ( $n = 15$ ) radiochemical yields after 17 and 20 min, respectively. Radiochemical purity was always >95% and molar activities exceeded  $792 \pm 100$  and  $88 \pm 6$  GBq/ $\mu$ mol, respectively. Quality control showed conformity with all relevant release criteria and radiopharmaceuticals were used in the clinic.

## KEYWORDS

clinical quality control, Ga-68, iPHASE MultiSyn, prostate cancer, PSMA-11, PSMA-617, theranostics

## 1 | INTRODUCTION

Prostate-specific membrane antigen (PSMA) is highly expressed in primary and metastatic lesions of prostate cancer.<sup>1</sup> Due to its low abundance in healthy tissues, PSMA targeting with peptides allows for highly targeted delivery with demonstrated accuracy for diagnosis of primary and metastatic prostate cancer, and for therapeutic indications.<sup>2–7</sup> A number of small molecules targeting the

extracellular domain of PSMA with exceptional affinity and specificity have been developed.<sup>8–10</sup> More recently, this has led to the development of diagnostic and therapeutic pairs of PSMA-targeting ligands. Although not a theranostic pair as per the definition, [<sup>68</sup>Ga]Ga-PSMA-11 and [<sup>177</sup>Lu]Lu-PSMA-617 are commonly used in this capacity and are under investigation in single site and multicentre clinical trials such as the TheraP and VISION studies.<sup>11–16</sup>

This is an open access article under the terms of the Creative Commons Attribution License, which permits use, distribution and reproduction in any medium, provided the original work is properly cited.

© 2020 The Authors. Journal of Labelled Compounds and Radiopharmaceuticals published by John Wiley & Sons Ltd

Protocols for the manual, semiautomatic and fully automatic production of [ $^{68}\text{Ga}$ ]Ga-PSMA-11 have been published with overall radiochemical production yields for manual and semiautomatic processes generally >90%<sup>17–22</sup> and fully automated procedures including product formulation ranging between 57–80% decay-corrected (d.c.) radiochemical yield.<sup>23–28</sup> Manual and fully automated production of [ $^{177}\text{Lu}$ ]Lu-PSMA-617 has been reported in >90% radiochemical yields.<sup>29–32</sup>

In order to facilitate PSMA clinical trials at Austin Health (Heidelberg, Australia), the radiosyntheses and formulation of [ $^{68}\text{Ga}$ ]Ga-PSMA-11 and [ $^{177}\text{Lu}$ ]Lu-PSMA-617 were automated and validated using an iPHASE (Melbourne, Australia) MultiSyn module.

## 2 | EXPERIMENTAL

### 2.1 | General methods

PSMA-11 was purchased from ABX (Radeberg, Germany); sodium acetate (99%), ultratrace water (for ultratrace analysis) and hydrochloric acid (37% w/w, 99.999% trace metal basis) were purchased from Sigma-Aldrich (Sydney, Australia); ethanol absolute (Emsure<sup>®</sup>) was purchased from Merck (Darmstadt, Germany); and saline (0.9% w/v) and water for injection (WFI) were purchased from Pfizer (NY, USA). Solutions of sodium acetate (0.25 M) and hydrochloric acid (0.1 M) were prepared from their respective stocks using ultratrace water and stored in containers at room temperature. PSMA-11 precursor used for radiolabelling was prepared by dissolving PSMA-11 (0.5 mg) in ultratrace water (2 ml). Aliquots of PSMA-11 precursor solution (50  $\mu\text{l}$ ) were pipetted into 2-ml Eppendorf tubes and stored at  $-4^\circ\text{C}$ . Strata-X solid-phase extraction (SPE) cartridges were purchased from Phenomenex (Melbourne, Australia).

GMP grade PSMA-617 was purchased from ABX (Radeberg, Germany). Lu-PSMA-617 high-performance liquid chromatography (HPLC) standard was purchased from Endocyte (IN, USA). Sodium acetate, gentisic acid and sodium ascorbate were purchased from Sigma-Aldrich (Sydney, Australia). A sterile stock solution of sodium acetate (0.4 M) was prepared, and aliquots were stored in sterile glass vials at room temperature. Standard hospital issue 0.22- $\mu\text{m}$  sterile filters, needles and WFI were used. Sterile glass vials were purchased from Huayi Isotopes (Changshu, China).

Gallium-68 was eluted from an Eckert & Ziegler IGG100 Gallium generator. No carrier added (n.c.a.) [ $^{177}\text{Lu}$ ]LuCl<sub>3</sub> in 0.04 M HCl was purchased from the Australian Nuclear Science and Technology Organisation (ANSTO, Lucas Heights, Australia). Sterile cassette kits

were purchased from iPHASE Technologies (Melbourne, Australia).

Thin-layer chromatography (TLC) of labelled PSMA-11 samples was performed using aluminium-backed silica gel 60 F<sub>254</sub> strips (Merck, Darmstadt, Germany) and a 1:1 (v/v) mixture of 1 M ammonium acetate and methanol as a mobile phase. Instant TLC (iTLC) of labelled PSMA-617 samples was performed using glass microfibre iTLC-SG chromatography paper strips (Agilent, CA, USA) and 1.9% disodium hydrogen citrate as a mobile phase. Reversed-phase HPLC (RP-HPLC) was performed on a Shimadzu LC-20 equipped with a SPD-20A UV-Vis detector and a LabLogic Flow-RAM scintillation detector using a Phenomenex Kinetex C18 5  $\mu\text{m}$  150  $\times$  4.6 mm column. Mobile phases were aqueous 0.08% TFA (A), acetonitrile (B), aq. 0.1% TFA (C) and 0.1% TFA in acetonitrile (D). Ga-PSMA-11 samples were analysed using a gradient of 5–80% D in C (v/v) over 10 min at a flow rate of 1.5 ml/min. Lu-PSMA-617 samples were analysed using a gradient of 15–35% B in A (v/v) over 15 min followed by 35–95% B in A (v/v) over 1 min and maintained for 3 min at a flow rate of 0.9 ml/min. Formulated material was analysed using a Charles River bacterial endotoxin testing unit.

### 2.2 | Automated production of [ $^{68}\text{Ga}$ ]Ga-PSMA-11

Upon start-up and installation of the hardware cassette excluding reagents, automated pressure testing was performed on all connections. The manifolds, reactor, SPE cartridge and reagent vial spikes were flushed with argon gas. Subsequently, reagents were installed as outlined in Figure 1. Vials containing ethanol (3.5 ml), saline (10 ml) and water (10 ml) were pushed onto their respective spikes on Manifold 4, and a solution of PSMA-11 (10  $\mu\text{g}$ , 9.88 nmol) in 0.25 M sodium acetate (1.6 ml) was added to the reactor via its centre port. A syringe containing 0.1 M HCl (5 ml) that was connected to the inlet of an Eckert & Ziegler IGG100 Gallium generator was placed in one of the syringe driver arms. The generator outlet was connected to Manifold 3. Finally, a 10-ml glass vial equipped with a vented 0.22- $\mu\text{m}$  sterile filter was connected to manifold 2. The reagent vials were then pressurised with inert gas, and the SPE cartridge was conditioned with ethanol from the reagent vial (approximately 2 ml), washed with water (5 ml) and flushed dry. Ethanol (approximately 0.2 ml) was transferred into the reactor, and gallium-68 was eluted from the generator using 0.1 M HCl in 0.3-ml increments over 1 min of elution time. The first fraction (1.5 ml) was discarded, and the second fraction (3.5 ml) was collected into the

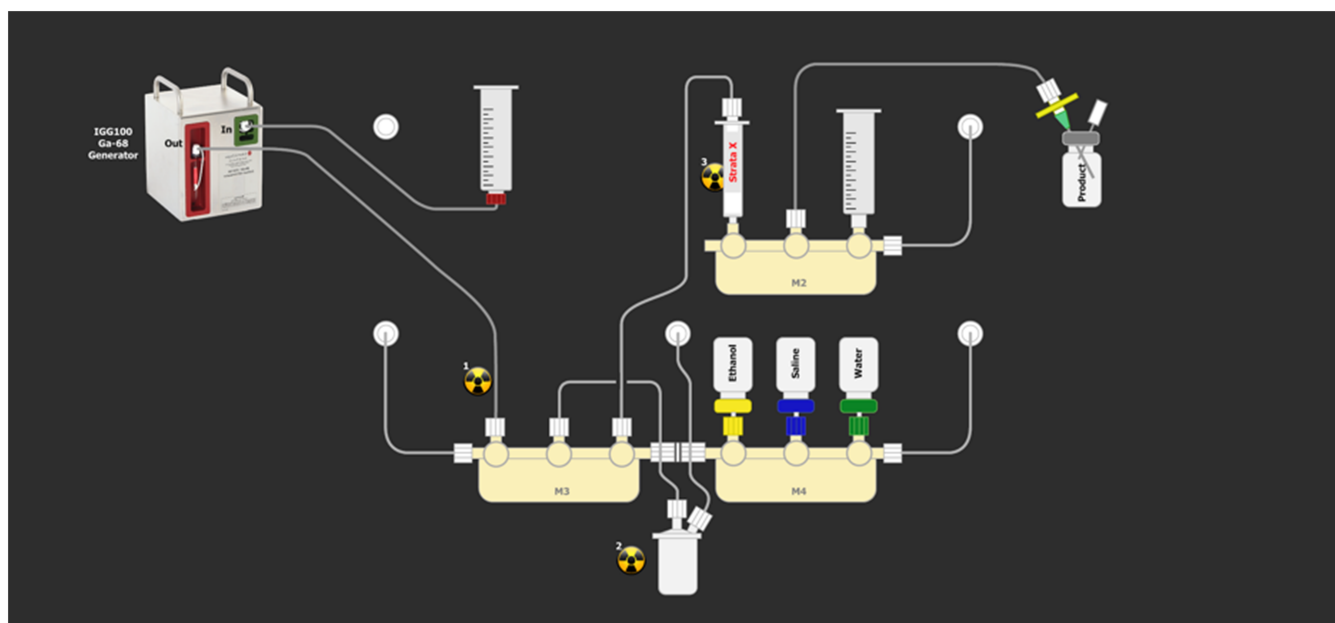

**FIGURE 1** Schematic overview of iPHASE MultiSyn cassette and reagent set-up for automated radiosynthesis of [ $^{68}\text{Ga}$ ]Ga-PSMA-11

preheated reactor. The reaction mixture was heated at 95°C for 5 min before being transferred over the SPE cartridge. Water (5 ml) was transferred first into the reactor and then loaded onto the SPE cartridge. The product was eluted from the SPE cartridge with ethanol (approximately 0.5 ml) using Syringe Driver 2 and diluted with saline (1.5 ml). The resulting solution was passed through a 0.22- $\mu\text{m}$  sterile filter and collected into the product vial. The reactor, SPE cartridge and transfer tubing from Manifold 2 to the product vial were flushed with further saline (5 ml) to complete formulation of the product.

### 2.3 | Automated production of [ $^{177}\text{Lu}$ ]Lu-PSMA-617

Automated pressure testing of all connections was performed with the manifolds, Transfer Syringe 3 (Manifold Position 6) and the reactor installed, and the reactor was flushed with inert gas. Subsequently, reagent vials and syringes were installed as described in Table 1.

[ $^{177}\text{Lu}$ ]LuCl<sub>3</sub> in 0.04 M HCl (approximately 1 ml) was transferred from the Lu-177 vial into the reactor. One millilitre of a 0.4 M sodium acetate solution containing PSMA-617 (125  $\mu\text{g}$ , 103 nmol) and 4-mg gentisic acid was transferred from Syringe 1 into the Lu-177 vial, remained there for 10 s and was transferred into the preheated reactor vial. After flushing the transfer line with inert gas, the reaction was heated to 95°C for 15 min. During the labelling reaction, half of the contents in Syringe 2, an aqueous solution containing 500-mg sodium ascorbate and 1-mg DTPA in 10-ml WFI, were drawn into

**TABLE 1** Reagent set-up for automated production of n.c.a. [ $^{177}\text{Lu}$ ]Lu-PSMA-617 using an iPHASE MultiSyn module

Location	Reagent/set-up
G1	Argon gas supply to manifold M1
W2	Liquid waste out from manifold M2 and argon/vacuum supply
R	Reactor vent with argon/vacuum supply
Manifold Position 1 <sup>SD</sup>	Syringe 1 (1 ml) containing PSMA-617 (125 $\mu\text{g}$ , 103 nmol) + 4-mg gentisic acid in 1-ml 0.4 M sodium acetate
Manifold Position 2	Line to Lu-177 vial with PEEK needle and 19 G vent needle
Manifold Position 3	Syringe 2 (10 ml) containing 500-mg sodium ascorbate + 1-mg DTPA in 10-ml water for injection
Manifold Position 4	Line to reactor vial
Manifold Position 5	Line to product vial (20 ml) with 0.22- $\mu\text{m}$ vented sterile filter + 21 G needle and 19 G vent needle
Manifold Position 6 <sup>SD</sup>	Syringe 3 (10 ml, empty)

Note: Manifold Positions 1 and 6 are equipped with syringe drivers (SD).

Syringe 3. At the conclusion of the reaction, the reactor vial was cooled to 40°C and the contents in Syringe 3 were transferred into the reactor vial. The reaction mixture was drawn into Syringe 3 and passed through a vented 0.22- $\mu\text{m}$  sterile filter into the product vial. The reactor vial was then flushed with the remaining sodium ascorbate/DTPA solution in Syringe 2 (approximately 5 ml),

and the solution was transferred into the product vial via Syringe 3. Finally, the transfer line and sterile filter leading to the product vial were flushed with inert gas.

### 3 | RESULTS AND DISCUSSION

#### 3.1 | Development of automated [<sup>68</sup>Ga] Ga-PSMA-11 synthesis protocol

Automated radiosynthesis of [<sup>68</sup>Ga]Ga-PSMA-11 was achieved on an iPHASE MultiSyn module using the set-up outlined in Figure 1. Gallium-68 was obtained from an Eckert & Ziegler IGG100 Gallium generator by elution with 5-ml 0.1 M hydrochloric acid. The first fraction (1.5 ml) was automatically discarded to reduce germanium-68 content and elution volume to enable easier buffering. The second fraction (3.5 ml) containing Ga-68 was collected into the reactor vial and used without prepurification or preconcentration. The reactor was charged with a small amount of ethanol prior to addition of the radioisotope to moderate radiolytic breakdown of reagents. Addition of the second generator fraction to the reactor vial containing PSMA-11 in sodium acetate resulted in a reaction pH of 4. Purification and reformulation of [<sup>68</sup>Ga]Ga-PSMA-11 was performed using a polymer-based SPE cartridge (Phenomenex Strata-X) before being sterile filtered into a sterile product collection vial (Figure S1 a-d).

Complexation of Ga-68 by PSMA-11 proceeded reproducibly in  $96.6 \pm 0.6\%$  ( $n = 8$ ) radiochemical yield (Figure 2, left). Overall, the process yielded [<sup>68</sup>Ga]Ga-PSMA-11 in  $76.2 \pm 3.4\%$  ( $n = 20$ ) radiochemical yield after 17 min. Residual activity in the reactor vial was negligible at  $0.18 \pm 0.08\%$  (Figure 2, right). Residual activity

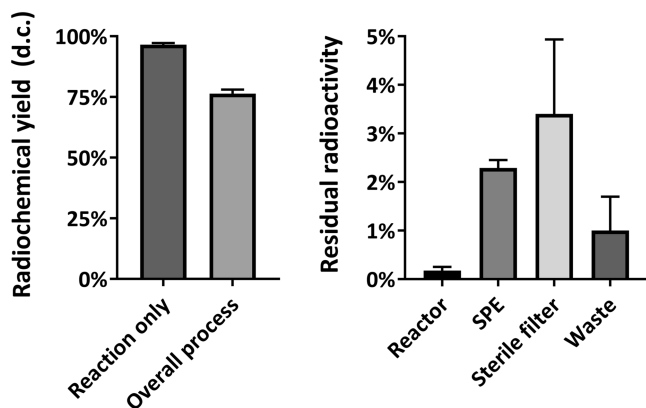

**FIGURE 2** Radiochemical reaction and overall process yield of the automated synthesis of [<sup>68</sup>Ga]Ga-PSMA-11 (left). Residual radioactivity ( $n = 8$ ) in the reactor vial, Strata-X solid-phase extraction (SPE) cartridge, sterile filter and waste (right). Data shown as mean  $\pm$  SD

on SPE cartridge and sterile filter accounted for the majority of losses with  $2.3 \pm 0.2\%$  and  $3.4 \pm 1.5\%$ , respectively. The waste contained  $1.0 \pm 0.7\%$  of the total activity eluted from the Ga-68 generator.

#### 3.2 | Development of automated [<sup>177</sup>Lu] Lu-PSMA-617 synthesis protocol

Quantitative complexation of <sup>177</sup>Lu<sup>3+</sup> with DOTA was achieved in 0.4 M sodium acetate solution at 95°C after 15 min at pH 4.5–5. The reaction was stabilised using gentisic acid, and the final product was formulated in sodium ascorbate containing DTPA. The process was automated using the cassette based iPHASE MultiSyn module (Figure 3). Fluid transfers were performed using either gas pressure/vacuum or the two available syringe drivers. Figure 4 shows a schematic overview of the installed synthesis cassette consisting of two manifolds, one reactor vial, three syringes and a product collection vial. The reagents and transfer lines were set up as described in Table 1.

Initially, we experienced large radioactivity losses due to residual [<sup>177</sup>Lu]LuCl<sub>3</sub> remaining in the Lu-177 vial (Figure 5). This was improved by flushing the Lu-177 vial with the precursor solution following isotope transfer into the reactor. This led to improved Lu-177 recovery in the reactor. Residual radioactivity remaining in the Lu-177 vial decreased by 55% from 15.0% to  $6.7 \pm 1.8\%$  ( $n = 3$ ). Losses in the Lu-177 vial transfer tubing were reduced by 94% from 6.6% to  $0.4 \pm 0.1\%$  ( $n = 3$ ).



**FIGURE 3** Picture of iPHASE MultiSyn set-up for automated radiosynthesis of [<sup>177</sup>Lu]Lu-PSMA-617 according to Figure 4 and Table 1

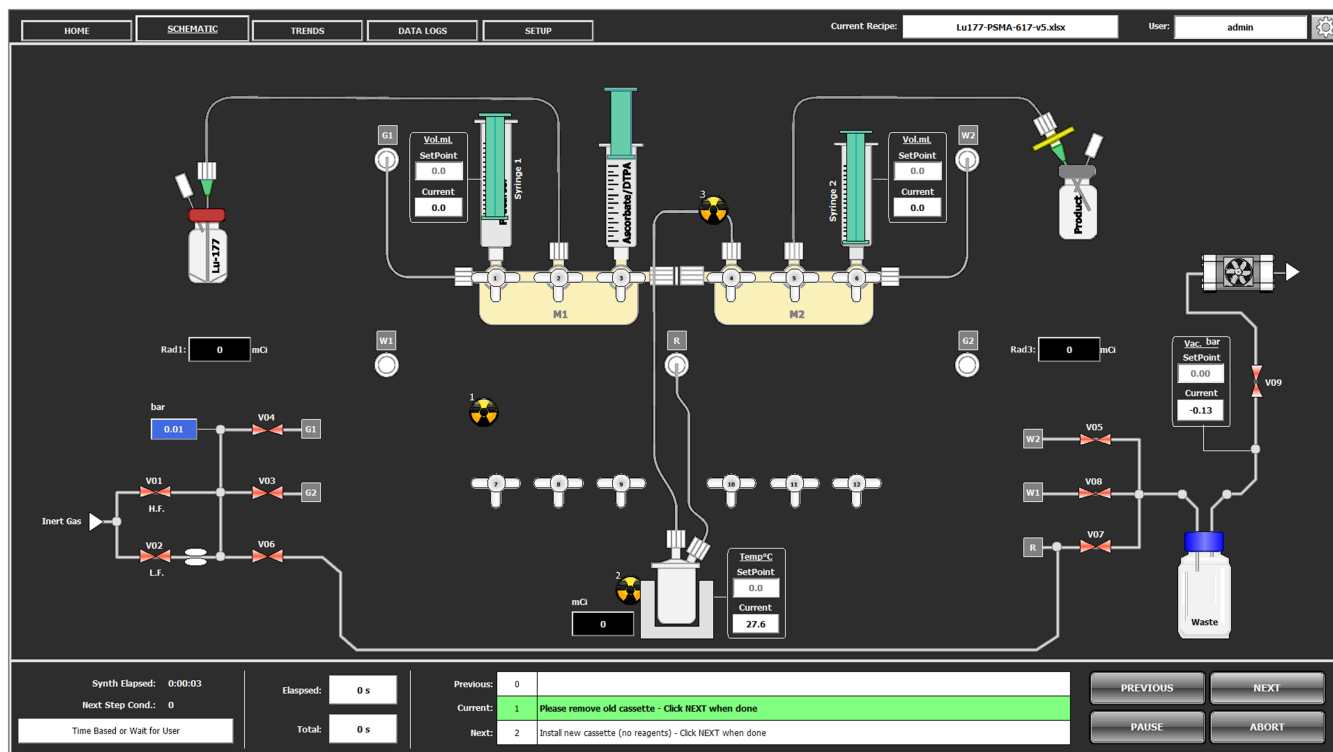

**FIGURE 4** Schematic overview of iPhase MultiSyn cassette and reagent set-up for radiosynthesis of [ $^{177}\text{Lu}$ ]Lu-PSMA-617 as described in Table 1

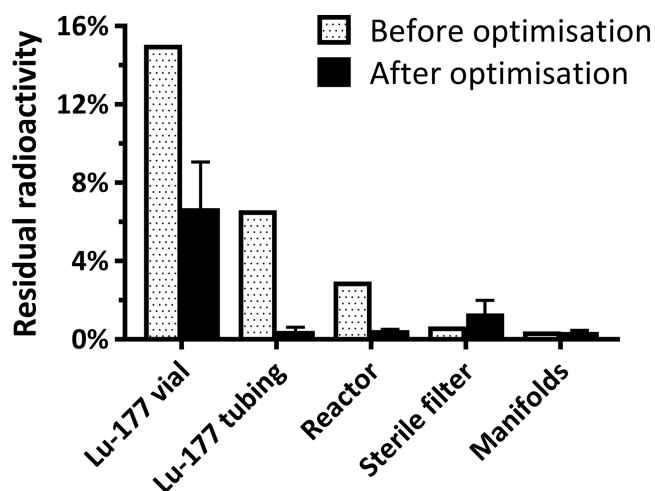

**FIGURE 5** Residual Lu-177 radioactivity before and after optimisation. Data shown as mean  $\pm$  SD ( $n = 1-3$ )

Losses during the recovery of [ $^{177}\text{Lu}$ ]Lu-PSMA-617 from the reactor were addressed by performing a saline wash of the reactor during product formulation resulting in  $0.5 \pm 0.0\%$  ( $n = 3$ ) of radioactivity lost in the reactor. Residual radioactivity on the sterile filter and in the manifolds remained constant at  $1.2 \pm 0.5\%$  ( $n = 4$ ) and  $0.4 \pm 0.1\%$  ( $n = 4$ ), respectively. This resulted in an overall increase in radiochemical yield of [ $^{177}\text{Lu}$ ]Lu-PSMA-617

from 75% to  $91.1 \pm 3.8\%$  ( $n = 14$ ) at end of synthesis (EOS). The total synthesis time was 20 min including formulation and sterile filtration (Figure S3 a-d).

### 3.3 | Quality control for clinical use

Quality control was performed on [ $^{68}\text{Ga}$ ]Ga-PSMA-11 and [ $^{177}\text{Lu}$ ]Lu-PSMA-617 according to the criteria outlined in Table 2. The reported results were obtained from 12 and 15 clinical productions, respectively. Sterile filters were tested for membrane filter integrity which was always  $>50$  psi. Where applicable, solvent analysis was performed which showed  $<10\%$  ethanol.

Overall, production of [ $^{68}\text{Ga}$ ]Ga-PSMA-11 proceeded in 76% (d.c.) radiochemical yield providing the product in a volume of 6.8 ml of  $<10\%$  ethanol in saline. HPLC analysis of residual PSMA-11 showed  $<1.0$   $\mu\text{g}$  PSMA-11 per production batch which results in molar activities of at least  $792 \pm 100$  GBq/ $\mu\text{mol}$  (EOS). Radiochemical purity via HPLC was always  $>99\%$  (both diastereomers combined) and free ionic (HPLC) and combined ionic/colloidal Ga-68 (TLC,  $R_f = 0.0-0.1$ ) were always  $<1.0\%$  and  $<3.2\%$ , respectively (Figure S2 a-d).

Production of [ $^{177}\text{Lu}$ ]Lu-PSMA-617 proceeded in 91% (d.c.) radiochemical yield providing the product in a volume of 9.4 ml. Molar activity was not a mandatory

**TABLE 2** Quality control results of [<sup>68</sup>Ga]Ga-PSMA-11 (*n* = 12) and [<sup>177</sup>Lu]Lu-PSMA-617 (*n* = 15); molar activities at end of synthesis (EOS) reported

Test	[ <sup>68</sup> Ga]Ga-PSMA-11	[ <sup>177</sup> Lu]Lu-PSMA-617
Overall production yield (d.c.) (%)	76 ± 3	91 ± 4
Product volume (ml)	6.8 ± 0.2	9.4 ± 0.7
Molar activity (EOS) (GBq/μmol)	>792 ± 100	>88 ± 6
Radiochemical identity	RT within 10% of standard	RT within 10% of standard
Radiochemical purity (HPLC) (%)	99.9 ± 0.2	96.6 ± 0.7
Residual Ga-68/Lu-177 (HPLC) (%)	0.11 ± 0.18	0.89 ± 0.52
Residual Ga-68 (ionic + colloidal)/Lu-177 (TLC) (%)	0.60 ± 0.51	0.62 ± 0.23
Chemical purity ( <i>m</i> <sub>PSMA</sub> ) (μg)	<1.0	-
Radionuclidic identity (T <sub>1/2</sub> ) (min/day)	67.7 ± 2.5	6.45 ± 0.06
Radionuclidic identity (MCA) (keV)	512.3 ± 1.6	-
Radionuclidic purity (%)	<0.001 Ge-68	>99.9
Appearance	Clear, colourless, particulate free	Clear, colourless—Slightly yellow, particulate free
pH	7.0 ± 0.1	7.0 ± 0.0
Sterility test	No growth after 14 days	No growth after 14 days
Bacterial endotoxin test (EU/ml)	<2.5 <sup>a</sup>	<2.5 <sup>a</sup>

Note: Data shown as mean ± SD.

<sup>a</sup>Limit of detection for bacterial endotoxins is 2.5 EU/ml.

release criterion for [<sup>177</sup>Lu]Lu-PSMA-617. Based on the starting amount of PSMA-617 (103 nmol) and the radiochemical purity, the molar activity was estimated to be  $\geq 88 \pm 6$  GBq/μmol (EOS). Radiochemical purity by HPLC was always  $\geq 95\%$  and unreacted lutetium-177 (iTLC, *R<sub>f</sub>* = 0.9–1.0) was always  $\leq 2.4\%$  (Figure S4 a-d).

Radionuclidic identity and purity were confirmed for both constructs. Sterility and bacterial endotoxin testing showed no positive results over the limit of detection. All productions fulfilled the quality control release criteria and were used in the clinic.

## 4 | CONCLUSIONS

In summary, the syntheses of a diagnostic and therapeutic pair of PSMA-targeting agents were automated using the same commercially available synthesiser. Production yields were comparable with other reported fully automated procedures. Both products passed quality control criteria without fail and are being used in clinical trials at the Austin Hospital.

## ACKNOWLEDGEMENTS

This work was supported in part by National Health and Medical Research Council (Grant No. 1143710 and 1092788), Operational Infrastructure Support from Victorian Government, and the Victorian Cancer Agency (Grant No. 1063413).

## ORCID

Christian W. Wichmann  <https://orcid.org/0000-0001-5341-8804>

## REFERENCES

- Smith-Jones PM, Vallabahajosula S, Goldsmith SJ, et al. In vitro characterization of radiolabeled monoclonal antibodies specific for the extracellular domain of prostate-specific membrane antigen. *Cancer Res.* 2000;60(18):5237-5243.
- Ghosh A, Heston WDW. Tumor target prostate specific membrane antigen (PSMA) and its regulation in prostate cancer. *J Cell Biochem.* 2004;91(3):528-539.
- Ceci F, Castellucci P, Fanti S. Current application and future perspectives of prostate specific membrane antigen PET imaging in prostate cancer. *Q J Nucl Med Mol Imaging.* 2019;63(1):7-18.
- Hope TA, Afshar-Oromieh A, Eiber M, et al. Imaging prostate cancer with prostate-specific membrane antigen PET/CT and PET/MRI: current and future applications. *Am J Roentgenol.* 2018;211(2):286-294.
- Eiber M, Fendler WP, Rowe SP, et al. Prostate-specific membrane antigen ligands for imaging and therapy. *J Nucl Med.* 2017;58(Supplement 2):67S-76S.
- Violet J, Sandhu S, Irvani A, et al. Long term follow-up and outcomes of re-treatment in an expanded 50 patient single-center phase II prospective trial of Lutetium-177 (<sup>177</sup>Lu) PSMA-617 theranostics in metastatic castrate-resistant prostate cancer. *J Nucl Med.* 2020;61(6):857-865.
- Perera M, Papa N, Roberts M, et al. Gallium-68 prostate-specific membrane antigen positron emission tomography in advanced prostate cancer—updated diagnostic utility,

- sensitivity, specificity, and distribution of prostate-specific membrane antigen-avid lesions: a systematic review and meta-analysis. *Eur Urol.* 2020;77(4):403-417.
8. Benešová M, Schäfer M, Bauder-Wüst U, et al. Preclinical evaluation of a tailor-made DOTA-conjugated PSMA inhibitor with optimized linker moiety for imaging and endoradiotherapy of prostate cancer. *J Nucl Med.* 2015;56(6):914-920.
  9. Chatalic KLS, Heskamp S, Konijnenberg M, et al. Towards personalized treatment of prostate cancer: PSMA I&T, a promising prostate-specific membrane antigen-targeted theranostic agent. *Theranostics.* 2016;6(6):849-861.
  10. Hofman MS, Lawrentschuk N, Francis RJ, et al. Prostate-specific membrane antigen PET-CT in patients with high-risk prostate cancer before curative-intent surgery or radiotherapy (proPSMA): a prospective, randomised, multicentre study. *The Lancet.* 2020;395(10231):1208-1216.
  11. Iravani A, Violet J, Azad A, Hofman MS. Lutetium-177 prostate-specific membrane antigen (PSMA) theranostics: practical nuances and intricacies. *Prostate Cancer Prostatic Dis.* 2020;23(1):38-52.
  12. Hofman MS, Emmett L, Violet J, et al. TheraP: a randomized phase 2 trial of  $^{177}\text{Lu}$ -PSMA-617 theranostic treatment vs cabazitaxel in progressive metastatic castration-resistant prostate cancer (Clinical Trial Protocol ANZUP 1603). *BJU Int.* 2019;124(S1):5-13.
  13. Hofman MS, Violet J, Hicks RJ, et al. [ $^{177}\text{Lu}$ ]-PSMA-617 radionuclide treatment in patients with metastatic castration-resistant prostate cancer (LuPSMA trial): a single-centre, single-arm, phase 2 study. *Lancet Oncol.* 2018;19(6):825-833.
  14. Bögemann M, Herrmann K, Radtke JP, Rahbar K. Radionuklidtherapie mit PSMA-Liganden bei fortgeschrittenem Prostatakarzinom. *Urologe.* 2020;59(6):680-686.
  15. Rahbar K, Bodei L, Morris MJ. Is the vision of radioligand therapy for prostate cancer becoming a reality? An overview of the phase III VISION trial and its importance for the future of theranostics. *J Nucl Med.* 2019;60(11):1504-1506.
  16. Rösch F, Herzog H, Qaim SM. The beginning and development of the theranostic approach in nuclear medicine, as exemplified by the radionuclide pair  $^{86}\text{Y}$  and  $^{90}\text{Y}$ . *Pharmaceuticals.* 2017;10(4):56.
  17. Nanabala R, Anees MK, Sasikumar A, Joy A, Pillai MRA. Preparation of [ $^{68}\text{Ga}$ ]PSMA-11 for PET-CT imaging using a manual synthesis module and organic matrix based  $^{68}\text{Ge}/^{68}\text{Ga}$  generator. *Nucl Med Biol.* 2016;43(8):463-469.
  18. Wang Y, Shao G, Wu J, et al. Preparation of  $^{68}\text{Ga}$ -PSMA-11 with a synthesis module for micro PET-CT imaging of PSMA expression during prostate cancer progression. *Contrast Media Mol Imaging.* 2018;2018:8046541.
  19. Amor-Coarasa A, Kelly JM, Gruca M, Nikolopoulou A, Vallabhajosula S, Babich JW. Continuation of comprehensive quality control of the itG  $^{68}\text{Ge}/^{68}\text{Ga}$  generator and production of  $^{68}\text{Ga}$ -DOTATOC and  $^{68}\text{Ga}$ -PSMA-HBED-CC for clinical research studies. *Nucl Med Biol.* 2017;53:37-39.
  20. Kurash MM, Gill R, Khairulin M, Harbosh H, Keidar Z.  $^{68}\text{Ga}$ -labeled PSMA-11 ( $^{68}\text{Ga}$ -isoPROtrace-11) synthesized with ready to use kit: normal biodistribution and uptake characteristics of tumour lesions. *Sci Rep.* 2020;10(1):3109.
  21. Lin M, Paolillo V, Ta RT, et al. Fully automated preparation of  $^{68}\text{Ga}$ -PSMA-11 at curie level quantity using cyclotron-produced  $^{68}\text{Ga}$  for clinical applications. *Appl Radiat Isot.* 2020;155:108936.
  22. Eder M, Schäfer M, Bauder-Wüst U, et al.  $^{68}\text{Ga}$ -complex lipophilicity and the targeting property of a urea-based PSMA inhibitor for PET imaging. *Bioconjug Chem.* 2012;23(4):688-697.
  23. Mueller D, Klette I, Kulkarni H, Baum R. Rapid synthesis of  $^{68}\text{Ga}$  labeled PSMA-HBED-CC in high radiochemical yield. *J Nucl Med.* 2017;58(supplement 1):906-906.
  24. Ceci F, Uprimny C, Nilica B, et al.  $^{68}\text{Ga}$ -PSMA PET/CT for restaging recurrent prostate cancer: which factors are associated with PET/CT detection rate? *Eur J Nucl Med Mol Imaging.* 2015;42(8):1284-1294.
  25. Garcia-Arguello SF, Lopez-Lorenzo B, Ruiz-Cruces R. Automated production of [ $^{68}\text{Ga}$ ]Ga-DOTANOC and [ $^{68}\text{Ga}$ ]Ga-PSMA-11 using a TRACERlab FXFN synthesis module. *J Label Compd Radiopharm.* 2019;62(3):146-153.
  26. Sørensen MA, Andersen VL, Hendel HW, et al. Automated synthesis of  $^{68}\text{Ga}/^{177}\text{Lu}$ -PSMA on the Trasis miniAllinOne. *J Label Compd Radiopharm.* 2020;63(8):393-403.
  27. Calderoni L, Farolfi A, Pianori D, et al. Evaluation of an automated module synthesis and a sterile cold kit-based preparation of  $^{68}\text{Ga}$ -PSMA-11 in patients with prostate cancer. *J Nucl Med.* 2020;61(5):716-722.
  28. Eder M, Neels O, Müller M, et al. Novel preclinical and radiopharmaceutical aspects of [ $^{68}\text{Ga}$ ]Ga-PSMA-HBED-CC: a new PET tracer for imaging of prostate cancer. *Pharmaceuticals (Basel).* 2014;7(7):779-796.
  29. Scarpa L, Buxbaum S, Kendler D, et al. The  $^{68}\text{Ga}/^{177}\text{Lu}$  theragnostic concept in PSMA targeting of castration-resistant prostate cancer: correlation of  $\text{SUV}_{\text{max}}$  values and absorbed dose estimates. *Eur J Nucl Med Mol Imaging.* 2017;44(5):788-800.
  30. Ahmadzadehfard H, Rahbar K, Kürpig S, et al. Early side effects and first results of radioligand therapy with  $^{177}\text{Lu}$ -DKFZ-617 PSMA of castrate-resistant metastatic prostate cancer: a two-centre study. *EJNMMI Res.* 2015;5(1):114-114.
  31. Kratochwil C, Giesel FL, Stefanova M, et al. PSMA-targeted radionuclide therapy of metastatic castration-resistant prostate cancer with  $^{177}\text{Lu}$ -labeled PSMA-617. *J Nucl Med.* 2016;57(8):1170-1176.
  32. Chakraborty S, Vimalnath KV, Chakravarty R, Sarma HD, Dash A. Multidose formulation of ready-to-use  $^{177}\text{Lu}$ -PSMA-617 in a centralized radiopharmacy set-up. *Appl Radiat Isot.* 2018;139:91-97.

## SUPPORTING INFORMATION

Additional supporting information may be found online in the Supporting Information section at the end of this article.

**How to cite this article:** Wichmann CW, Ackermann U, Poniger S, et al. Automated radiosynthesis of [ $^{68}\text{Ga}$ ]Ga-PSMA-11 and [ $^{177}\text{Lu}$ ]Lu-PSMA-617 on the iPHASE MultiSyn module for clinical applications. *J Label Compd Radiopharm.* 2021;64:140-146. <https://doi.org/10.1002/jlcr.3889>