



Minerva Access is the Institutional Repository of The University of Melbourne

Author/s:

Gubbi, J;Marusic, S;Rao, AS;Law, YW;Palaniswami, M

Title:

A Pilot Study of Urban Noise Monitoring Architecture Using Wireless Sensor Networks

Date:

2013-01-01

Citation:

Gubbi, J., Marusic, S., Rao, A. S., Law, Y. W. & Palaniswami, M. (2013). A Pilot Study of Urban Noise Monitoring Architecture Using Wireless Sensor Networks. 2013 INTERNATIONAL CONFERENCE ON ADVANCES IN COMPUTING, COMMUNICATIONS AND INFORMATICS (ICACCI), pp.1047-1052. IEEE. <https://doi.org/10.1109/ICACCI.2013.6637321>.

Persistent Link:

<https://hdl.handle.net/11343/313852>

# A Pilot Study of Urban Noise Monitoring Architecture using Wireless Sensor Networks

Jayavardhana Gubbi, Slaven Marusic, Aravinda S. Rao, Yee Wei Law, and Marimuthu Palaniswami

Department of Electrical and Electronic Engineering, The University of Melbourne,  
Parkville Campus, VIC - 3010, Australia.

{jgl@, slaven@, aravinda@student., ywlaw@, palani@}unimelb.edu.au

**Abstract**—Internet of Things (IoT) is defined as interconnection of sensing and actuating devices providing the ability to share information across platforms through a unified framework, developing a common operating picture for enabling innovative applications. As the world urban population is set to cross unprecedented levels, adequate provision of services and infrastructure poses huge challenges. The emerging IoT that offers ubiquitous sensing and actuation can be utilized effectively for managing urban environments. In this paper, a new architecture for noise monitoring in urban environments is proposed. The architecture is scalable and applicable to other sensors required for city management. In addition to the architecture, a new noise monitoring hardware platform is reported and visualization of the data is presented. An emerging citizen centric participatory sensing is discussed in the context of noise monitoring.

## I. INTRODUCTION

Exposure to excessive noise levels is known to negatively impact quality of life. These effects, though largely subjective, can be broadly categorized as annoyance (affective-emotional response), affected concentration, communication disturbance and sleep disruption. While instances of sleep disruption and affected concentration (represented by interruption of an activity in response to a noise occurrence) can be measured, annoyance is determined based on the perception of given sounds or as a consequence of the former effects. Further to this, exposure to excessive noise levels is known to have detrimental health impacts (at sound pressure levels above 65 dBA). Some of these effects include (a) stress, anxiety contributing to mental illness; (b) pain (at 120 dB); hearing damage (at 85dB); (c) sleep disorders, hypertension; heart diseases [1], [2]. A single burst of noise can affect endocrine, neurological and cardiovascular function, while frequent exposure can result in chronic physiological disturbance. Experts estimated 80 million people suffered unacceptable noise levels and 170 million experience serious annoyances during daytime in the EU [3]. A 2007 social survey by Australian state Victoria's EPA found that almost half of its people (49 per cent) were disturbed or annoyed by environmental noise and one-quarter (24 per cent) of respondents reported sleep disturbance at some stage in the previous 12 months. The World Health Organization (WHO) has developed Guidelines for Community Noise (1999) and while mean levels across Melbourne are close to these guidelines, the number of sites exceeding recommended levels is significant [4].

In the context of noise monitoring in Australia, traditionally a questionnaire based survey is conducted amongst subjects of interest to assess the noise conditions [5]. The response was used to create a code of practice to reduce the effects of

noise monitoring. As it is clear, such an approach will result in reassessment and modifications although the method results in improved working conditions. In the recent past, city councils have been using modeling approaches to simulate the noise in the urban environment. Although this approach is acceptable, they fail to capture the sporadic noises created in a crowded atmosphere [6]. Recent results based on the work conducted in Brisbane suggests that the monitoring approach is by far the preferred approach over modeling and the noise was monitored in 330 locations to come up with legislations on noise [6]. However, in their study, authors clearly point out the risk involved to the staff who have to be physically present in the location where the noise is being monitored.

Urban wireless sensor networks (WSN) offers a decent solution for addressing the noise monitoring challenge. It not only offers continuous noise data over long periods of time but also gives the flexibility of sensing more information including photo snapshots and other environmental parameters without anybody being physically present at the locations. The traditional WSNs offer the advantage of obtaining uninterrupted data but requires new infrastructure to be installed. On the other hand, mobile devices offer the convenience of flexibility and involvement of general public in council affairs but does not offer meaningful long term data for taking strong measures. Recently, some interesting work has been reported in noise monitoring literature. They can be mainly classified under two categories - (a) monitoring using traditional WSNs (b) monitoring with hand held devices such as smart phones. Bennett *et al.* [7] propose a new platform for measuring noise parameters in transit. They have reported several tests about varying patterns of noise captured in different predefined paths and different sensor locations. They also report a host of improvements possible including GPS location, reliability of the data and validation of results in mobile environment. Kanjo *et al.* [8] have reported a mobile phone application called NoiseSpy which logs movement of people and the corresponding noise levels. This is a very useful approach for a people centric approach where a mobile phone of any user can become a mobile sensor and ensures public participation in policy making. Rana *et al.* [9] propose an end to end participatory mobile phone based noise monitoring application with compressive sensing strategies for missing data. Santini *et al.* [10] report their first experience in using a traditional WSN for noise monitoring application. They use Tmote as the development platform for their work. In the first work of its kind they report their end to end work with decent results. Same authors further work and report the common pitfalls and open issues in the implementation of wireless noise monitoring

systems with emphasis on context awareness, unobtrusiveness, correctness and energy awareness [11].

The ideal scenario would be a new architecture which will create a framework for both to co-exist and be able to provide meaningful long term data at low cost and by involving the general public. A smart city is built on ubiquitous sensing capabilities enabled by large scale WSN technology that reaches across numerous areas of modern living, offering the ability to measure and understand the condition of environmental parameters. The proliferation of sensing devices is creating an 'Internet of things,' (IoT) requiring connection of distinct elements, combining different data and infrastructures, where meaningful information can be shared across different platforms and translated into action. The critical enabling capability that defines the smart city concept includes - (a) the collection of vast amounts of sensor data; (b) cross-domain information management frameworks; (c) translation of meaningful information into knowledge; (d) enabling informed decision making and action. This concept is being applied in the first instance to be able to better measure, monitor, understand and manage noise issues within the urban environment. From our discussions with the Melbourne City Council staff, we have identified the need to capture data at different levels of a tall building as the complaints are often received from higher levels and less from the lower levels. For objective noise analysis a three dimensional noise map is an ideal solution in such cases which is possible using a urban WSN. Continuous monitoring will provide consistent and verifiable reference points for evaluation of noise issues and effectiveness of response measures. This paper proposes a new architecture and reports development of necessary hardware for accomplishing the objective. The framework allows collection of sound data along with other environmental parameters such as temperature, humidity and light. Moreover, in all the previous work, a commercial noise level meter or a microphone with built in preamplifier is used. A sensor mote is used only as a data aggregation and communication unit with no processing happening locally. In this paper, we report on the development of our own prototype circuitry for determining noise level.

## II. NOISE MONITORING ARCHITECTURE

The schematic of the proposed architecture is given in Figure 1. Based on the nature of operation, the data collection step can be divided into two - fixed infrastructure and mobile infrastructure. The mobile infrastructure can include sensors mounted on vehicles, mobile phones and other hand held devices. Due to the nature of collection, the data collection cannot be continuous and the hardware should be capable of higher processing, networking, geographical location and hold its own power supply. They are useful in people centric approaches where the citizens will contribute to city council's policy making. They enrich data collected by fixed infrastructure by filling gaps in spatial data and help citizens in filing noise complaints where fixed infrastructure facilities are not available. They play a major role in measurement of entertainment noise. Apart from not providing continuous measurement, they also lack calibration and comparison of data due to variable hardware employed.

Fixed infrastructure in this context is a realization of WSNs in urban monitoring. The proposed architecture is two-

tiered including high communication, low processing power backbone node and a low communication, high processing power sensing node. The schematic is shown in Figure 2. Node B in Figure 2 is the low power high communication range node. Any number of clusters can be formed away from the base station. These nodes should be capable of mesh networking. With a higher communication range they are the best candidates to form backbone infrastructure. The commercial sound level meter with analog output can be easily interfaced into the analog to digital converter (A/D) on the sensor board. Apart from sensing the data using a sound level meter, they route the data from other nodes to the base station with other environmental parameters. Nodes 1, 2 and 3 in Figure 2 indicate other high powered low communication range nodes which forms the branches and leaves of the network. They have the ability to interface different sensors, aggregate data and other data processing operations. They do not communicate with base station directly but instead route the data to base via the backbone nodes B. The data from the fixed infrastructure and mobile infrastructure are time stamped and stored in a server. The data is then visualized using geo-spatial maps or on hand held devices as shown in Figure 1.

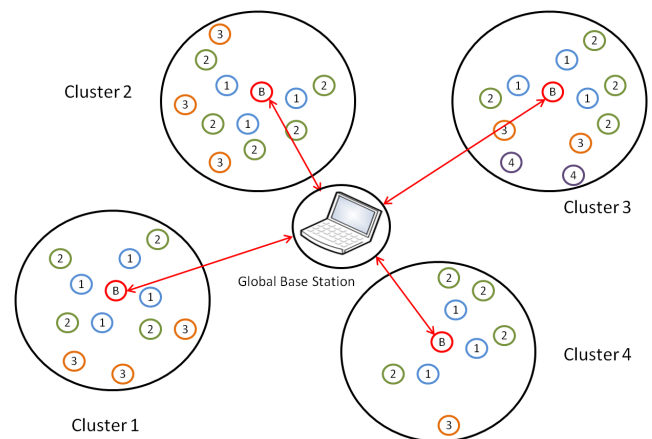

Fig. 2: Architecture of the proposed scheme

## III. NOISE MONITORING PLATFORMS

As described in the previous section, different nodes perform dedicated functions. In this section, we present the implementation details and experiment setup. Based on the architecture of fixed infrastructure, the platform selected, selection consideration and the intended function is summarized in Table I. The commercial sound level meter is connected to the Crossbow's IRIS nodes which are low power, high communication range and low processing power nodes. They form the backbone of the proposed architecture. Ideally they are powered by constant power supply due to the nature of operation and the location of the backbone is preplanned in order to ensure high quality of service. The MDACA100 data acquisition board is used for data collection. The A/D converter on the data acquisition board is used to sample the noise meter reading at 2 Hz resolution. No processing is required as the sound meter provides the output in A-weighted decibels (dBA) values. Use of commercial meters ensure that the sensor

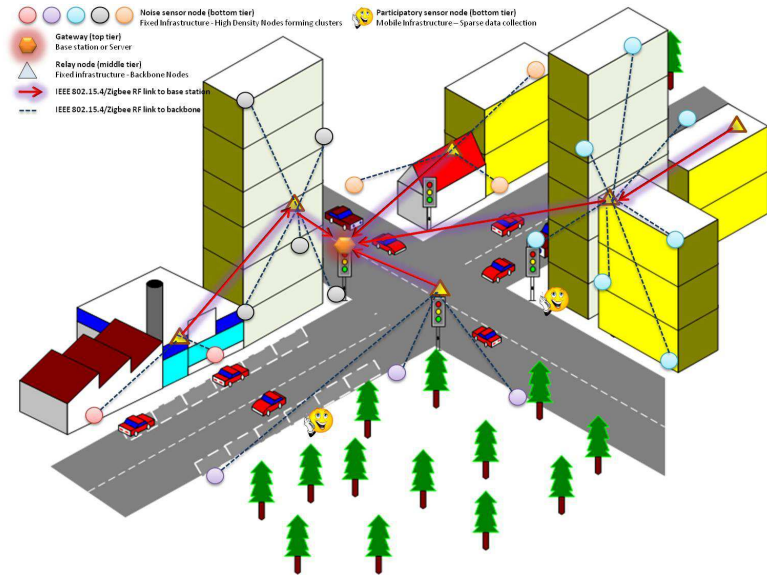

Fig. 1: Architecture of the proposed scheme based on SmartSantander Architecture [12]

TABLE I: Summary of selected sensing platforms in adherence with proposed architecture

	Typical platforms	Comm. range and details	Module lifespan and processing capabilities	Cost (Based on 2009 quotes from Crossbow)	Role
Fixed Infrastructure - High Density Nodes	Crossbow iMote2	30-60m; sends the message to the nearby sink node	Few hours to one day on 3 AAA battery; Higher processing power enables in-network processing and multiple sensor interface.	Cost of each node includes the iMote2 cost, sensor cost and the housing. Typically, 1,000 per unit.	Custom designed circuitry with decibel calculation carried out in respective mote; Ideally forms the branches and leaves of the network.
Fixed Infrastructure - Backbone Nodes	Crossbow IRIS	100-300m; Linked to base station using Xmesh technology.	Ideally should be connected to constant power source; 3-4 days on 2 AA batteries; Has low or no processing power. Hence can only be used for acquisition and routing of data.	Cost of each node includes cost of IRIS, Sound level meter and the housing. Typically, 700 per unit.	Uses commercial hand held meters and mainly used as network sound calibrator and router; Forms the backbone of the network.
Mobile Infrastructure	Smart phones such as iPhone and HTC	Seamless using existing 3G infrastructure.	On battery for a few minutes; Usually high processing capabilities and visualization	Cost of mobile phones	Helps in people centric approach and enriches the data captured using flexible and fixed infrastructure.

network backbone noise readings are according to industry standards and can be used to calibrate other custom designed sensors if required.

The second tier of our network which forms leaves and branches of the network in our architecture is not as straight forward. Crossbow's iMote2 2410 motes are chosen for this operation that have 30 m communication range and can be easily extended to 60m with an external antenna. They have high processing power and also possess high storage in the form of 32MB flash memory. Moreover, both IRIS and iMote2s work on 2.4GHz band. ITS400 sensor board is used for data acquisition using the A/D port. A commercial sound level meter can be used for data acquisition similar to the backbone. In the case of the proposed architecture, a basic sound acquisition module has been designed which interfaces with iMote2. This is a low cost circuitry but is subject to data drift which is an acceptable trade-off in the case of large scale deployments. The use of standard sound level meters in the backbone ensures fault identification and the drift can be corrected from time to time via software calibration.

#### A. Sound Acquisition and Premplification

The output of the microphone needs to be amplified before the it is connected tot he A/D convertor on ITS400 sensor board. We designed an amplifier based on [13] as shown in Figure 3. The circuit uses 3V from the ITS400 sensor board and the output of the circuit is connected to one of the four A/D ports. The acquired data is converted to sound level on the node before being transmitted to one of the backbone nodes. AM4011 is an electret microphone that can function in the frequency range of 50 – 12.5 kHz range. The operating voltage of AM4011 is from 1.5V to 15V dc. The sensitivity of the microphone is  $-59 \pm 3$  dB. AM4011 is biased using resistor  $R1$ . Next, the high pass filter formed by  $C1$  and  $R2$  acts as a high-pass filter with a cut-off frequency of 1.6 Hz. The electrolytic capacitor  $C1$  also filters the dc bias from the microphone-generated ac signal. The signal is then fed to the operational amplifier for amplification of low-level microphone signal. This signal is then fed to A-weighting filter, intermediate amplifiers and averaging filters.

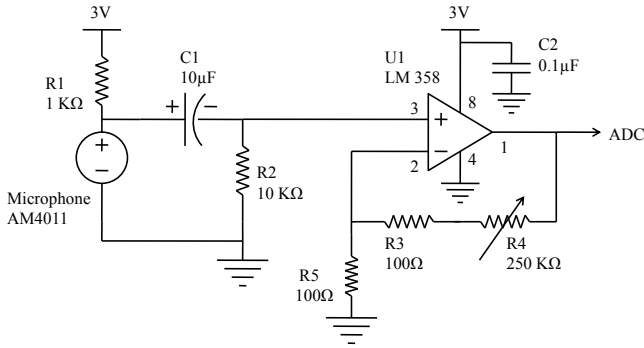

Fig. 3: Circuit diagram of the sound acquisition module (pre-amplifier)

### B. Hardware-level Conversion of Sound Levels into dBA

For a microphone signal to be converted to dBA signal, the signals from the microphone must be A-weighted. One of the methods is to sample the microphone signals and convert them into dBA-equivalent levels. This process is named as *software-level* conversion. The signal obtained from the microphone is passed through the low pass filter with the cut-off frequency at 22.05 kHz. This is converted to frequency domain by passing through a FFT filter and multiplied with A-weighting filter given by equation 1 [14]. It should be noted that the circuit is not as accurate as the original filter design but for demonstration purposes we have chosen a simple design which will be later improved. The main disadvantage of the hardware format is the lack of representation of the ear's abrupt sensitivity loss due to aging. The software digital filter has been designed but this cannot be used on iMote2 as the sampling frequency of A/D on iMote2 is limited to 1 kHz and this clearly is not enough for a urban noise monitoring project which requires 44.1 kHz sampling rate.

$$\alpha(f) = \frac{(3.504 * 10^{16}) f^8}{(20.598^2 + f^2)^2 * (107.65^2 + f^2) * (737.862^2 + f^2) * (12194.217^2 + f^2)} \quad (1)$$

The result of multiplying A-weighted filter with the spectrum can be represented as  $X_A[k]$ . The signal energy of the A-weighted spectrum can be calculated using equation 2.

$$P(x) \approx \frac{2}{N} \sum_{k=0}^{\frac{N}{2}} |X_A[k]|^2 \quad (2)$$

In case of WSNs, the above approach becomes cumbersome due to bandwidth of the audible range (20 - 22.05 kHz) and consequently, the Nyquist rate sampling. As a result, the sampling frequency of 44.1 kHz and eventual storage of these samples in sensor nodes in highly infeasible. Therefore, the above process of converting the captured microphone sound levels into dBA equivalent is carried out using dBA-equivalent hardware filters. This process is termed as *hardware-level* conversion. This provides a threefold edge over noise monitoring: (a) signals are captured continuously in real-time, (b) the computational and storage load over sensor nodes are drastically reduced, and (c) the noise frequencies pertaining to entire audible range is acquired. In this work, the same filter

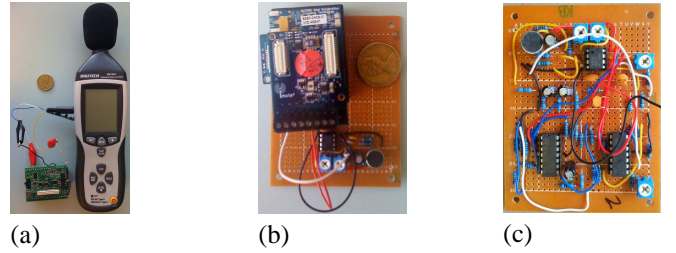

Fig. 4: (a) Sound level meter connected to IRIS motes and (b) iMote2 with preamplifier, (c) Custom designed noise meter with preamplifier and *hardware-level* conversion

has been realized as a hardware block as shown in Figure 3. Signal level in dBA is calculated using equation 3.

$$\text{Noise in dB(A)} = 10 * \log_{10}(P(x)) + C \quad (3)$$

where,  $P(x)$  is the calculated signal energy and C is the calibration constant which is determined by experimentation. It is observed that the range of the designed circuit is 40-120 dB with sensitivity of 0.01 V/dB against 30-140 dB of a commercial noise level meter used with IRIS. The values are comparable to low cost commercial noise level meters. The pictures of IRIS and iMote2 with respective sound level meters are shown in Figure 4. Figure 4-(c) is custom noise meter developed and used to monitor noise continuously with iMote2. Figure 5 shows the calibration of custom noise meter with commercial noise meter.

### C. Participatory Sensing or Crowd Sourcing

A reliable system for measuring noise, monitoring noise and responding to noise issues is the key driver in development of systems for urban noise sensing. However, fixed sensing infrastructure, particularly in the context of high density deployments, has substantial cost implications. The wide availability of mobile sensors (eg. smart phones) presents other opportunities for collecting vital environmental information. Participatory sensing is the process whereby individuals and communities use evermore capable mobile phones and cloud services to collect and analyze systematic data for use in discovery. The proximity of the sensor to the point of interest when considering the subjective impact of noise, makes PS an attractive capability. The functionality of smart phones, as seen with respect to social media, provides a convenient mechanism for sourcing user feedback in addition to raw data collected by the sensors on the device. PS as a crowd-sourcing platform as well as a mobile people-centric sensing platform, provides a mechanism for engaging citizens, in addition to obtaining valuable feedback and an understanding of the public perceptions of noise and urban sounds. In the proposed architecture, we propose to include a spare mobile participatory sensing layer for noise data collection. To this effect, a mobile phone application is being developed for Android and iOS platforms.

## IV. RESULTS AND DISCUSSION

In this paper, a new architecture and related hardware development for monitoring noise in urban environment is proposed. The architecture includes both fixed and mobile infrastructures for noise data collection. A new A-weighted

filter having the ability to capture only sound level without retaining any sound data is designed and tested. This is highly important because of citizen privacy reasons. We have tested our new hardware-level sound meter against commercial sound meter. The data was collected continuous in the lab with a star network connection (connecting base station to central database) as shown in Figure 2. With meticulous analysis of noise levels and its properties, we have proposed a 3D noise mapping architecture using WSNs as shown in Figure 1. Further, an introduction to the use of participatory sensing is described.

The hardware circuit consists of preamplifier, A-weighting filter and intermediate amplifiers, and averaging filters. Because of adoption of hardware filters, the circuit process the incoming signal from microphone in real-time. In addition, there is now bandlimiting filters incorporated into the circuit except for frequencies above 22.05 kHz at the base station. Therefore, the entire audible range of signals can be processed. The averaging filters provide the output voltage levels that correspond directly to dBA level signal. It is important to note the fact that most of the wireless sensor platforms use 8 kHz low-pass filter, digitize the signal and then analyze the signal in different octave bands to obtain dBA values.

In contrast, our custom hardware has the ability to process the signals in the analog domain. The results of the developed noise monitoring platform (at node level) is shown in Figure 5. As it can be seen in the top panel of the figure, the voltage output of the developed platform matches the original noise level quadratically. Once the quadratic model is calculated, the future values are converted from voltage to dB using the model. The bottom panel of Figure 5 shows calibrated and uncalibrated output of a minute of artificial highly varying sound. As it can be seen, the calibrated output matches the original decibel readings. Numerically, the designed platform has an error of  $\pm 2$  dB when compared with commercial sound level meter.

From the results, it is clear that our results were catching up with commercial noise level meter values. The rationale behind this is the fact that information is lost as soon as the signal is transformed into digital domain. Since we are processing in the analog domain at hardware level, the values are closely matching. Furthermore, if we want capture the 22.05 kHz signal for analysis, the system needs to sample at a minimum of 44.10 kHz. Firstly, this is highly impractical for a sensor system to achieve this sampling rate. Secondly, even if the system has the ability to sample at high rates, the storage of massive amounts of data because of high sampling rate would outrun the memory of the sensor node. Considering, these facts, our custom hardware provides promising solution to acquire noise information for sensor networks and our approach is unique and novel compared to others.

Once the data is collected, the data is stored in the server. Currently, the data is being stored in COSM server (previously PACHUBE [15]) for analysis at network level. For visualization publicly available COSM iPhone application is used for mobile platform as shown in Figure 6. For desktop, Google maps are used as shown in Figure 6 (available on <http://www.issnip.org/Feeds.php>). The location of the sensors are input manually by the user as the proposed architecture



Fig. 6: Visualization using Google platform (left) and Visualization using COSM i-Phone application(right)

involves fixed infrastructure but for mobile infrastructure the GPS of the smart phone supplies the location.

In participatory sensing research conducted thus far, a few key hurdles impacting the uptake of this technology from both citizen and government perspectives have been identified. A mobile phone application capturing the noise data and uploading it to the server is developed. The establishment of incentivisation criteria to deliver genuine citizen engagement is essential. This demands that the security of the system and the privacy of city inhabitants and contributors of people-centric data must be preserved. This can be managed on a number of levels, from system data collection, usage and access policy decisions, through to technological solutions providing capabilities for encryption and anonymisation of data. Data quality, integrity and reliability is necessary to meet specific needs at different levels of government. Data integrity needs to be insured by incorporating fixed infrastructure data and verifying what user deposits.

## V. CONCLUSION

A novel scalable multi-tier architecture for continuous monitoring of noise in urban environment is presented. The designed hardware platform processes the noise signal in analog domain and converts it into sound levels ensuring privacy protection. Visualization and interpretation of the data is achieved using Google maps. The qualitative and privacy challenges using participatory sensing in the context of noise monitoring is discussed. An end-to-end research and

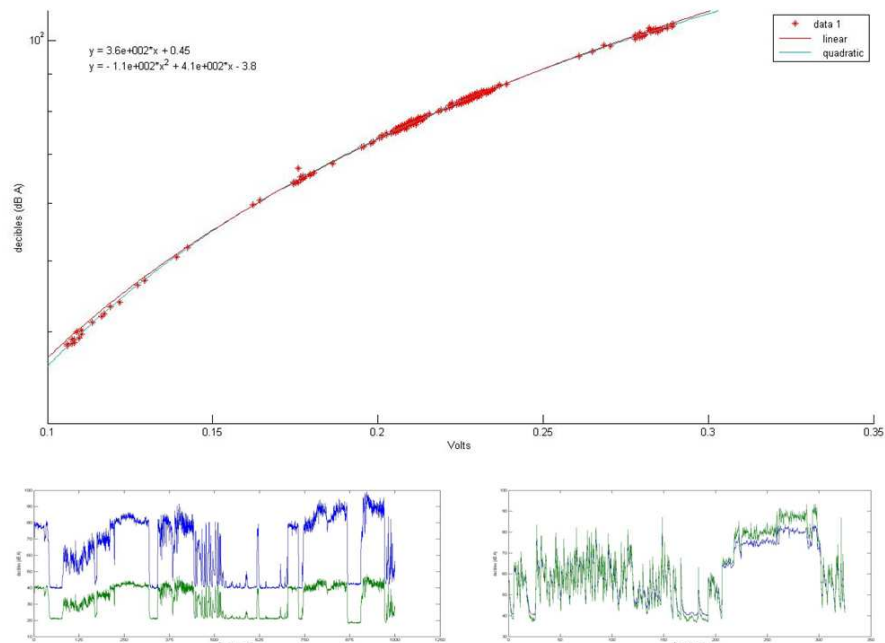

Fig. 5: Calibration results of the new noise monitoring platform designed (Top). Noise output from a commercial system and the developed noise monitoring platform without calibration (bottom left). Noise output from commercial system and developed noise monitoring platform with calibration (bottom right)

development including architecture, hardware platform, data management and interpretation is demonstrated with real-time experiments.

#### ACKNOWLEDGEMENTS

The work is partially supported by Australian Research Council's LIEF (LE120100129), Linkage grants (LP120100529) and IBES grant on participatory sensing. The authors are participants in European 7<sup>th</sup> Framework projects on SmartSantander and Internet of Things - Initiative and are thankful for their support.

#### REFERENCES

- [1] L. Sobotova, J. Jurkovicova, Z. Stefanikova, L. Sevcikova, and L. Aghova, "Community response to environmental noise and the impact on cardiovascular risk score," *Science of the Total Environment*, vol. 408, pp. 1264–1270, 2010.
- [2] A. Vernez Moudon, "Real noise from the urban environment: How ambient community noise affects health and what can be done about it," *Am J Prev Med*, vol. 37, no. 2, 2009.
- [3] H. Miedema, "Annoyance caused by environmental noise: Elements for evidence-based noise policies," *Journal of Social Issues*, vol. 63, no. 1, pp. 41–57, 2007.
- [4] M. Victorian Government, "Information bulletin," *EPA Noise Surveys 2007*, vol. 1169, October 2007.
- [5] J. Guo and P. Gubb, "Entertainment noise in western australia," in *Proceedings of Acoustics 2005*, 2005, pp. 211–215.
- [6] D. Borgeaud, "Noise mapping an entertainment precinct," in *Proceedings of Acoustics 2005*, 2005, pp. 211–215.
- [7] G. Bennett, E. King, J. Curn, V. Cahill, F. Bustamante, and H. J. Rice, "Environmental noise mapping using measurements in transit," in *Proceedings of Acoustics 2005*, 2010, pp. 1795–1810.
- [8] E. Kanjo, "Noisespy: A real-time mobile phone platform for urban noise monitoring and mapping," *Mobile Networks and Applications*, vol. 15, pp. 562–574, 2010, 10.1007/s11036-009-0217-y. [Online]. Available: <http://dx.doi.org/10.1007/s11036-009-0217-y>
- [9] R. K. Rana, C. T. Chou, S. S. Kanhere, N. Bulusu, and W. Hu, "Ear-phone: an end-to-end participatory urban noise mapping system," in *Proceedings of the 9th ACM/IEEE International Conference on Information Processing in Sensor Networks*, ser. IPSN '10. New York, NY, USA: ACM, 2010, pp. 105–116. [Online]. Available: <http://doi.acm.org/10.1145/1791212.1791226>
- [10] S. Santini, B. Ostermaier, and A. Vitaletti, "First experiences using wireless sensor networks for noise pollution monitoring," in *Proceedings of the workshop on Real-world wireless sensor networks*, ser. REALWSN '08. New York, NY, USA: ACM, 2008, pp. 61–65. [Online]. Available: <http://doi.acm.org/10.1145/1435473.1435490>
- [11] S. Santini, B. Ostermaier, and R. Adelman, "On the use of sensor nodes and mobile phones for the assessment of noise pollution levels in urban environments," in *Proceedings of the Sixth International Conference on Networked Sensing Systems (INSS 2009)*, Carnegie Mellon University, Pittsburgh, USA, Jun. 2009.
- [12] S. E. F. Project, "Smartsantander outdoor city-based santander testbed," Testbed Online Document, 2012 (verified in April 2013).
- [13] T. Engdahl, "Powering microphones," ePanaorama online document, 1997 (verified on 2nd Feb 2011).
- [14] U. Beis, "Weighting filter set," Elektronik Audio Measure Online Document, 2006 (verified on 25th Feb 2011).
- [15] Pachube, "Pachube data infrastructure," Online Document, Available as on 25th Feb 2011).